

GAS PROCESS BURNERS INSTALLATION, OPERATING AND MAINTENANCE MANUAL

ONE STAGE, TWO-STAGE AND MODULATING OPERATION



FPB 20
FPB 80
FPB 200
FPB 300
FPB 400
FPB 550
FPB 870

FPB 1200
FPB 1600
FPB 2000
FPB 2500
FPB 3500
FPB 5000



DEAR USER,

ECOSTAR FPB (20, 80, 200, 300, 400, 550, 870, 1200, 1600, 2000, 2500, 3500, 5000) gas process burners are prepared and manufactured according to the latest technical developments and safety rules. It is easy to use for our customers.

We recommend that you read this manual and safety warnings thoroughly before the use of the device in order to ensure safe, cost effective and environmental-friendly use.

If you encounter any issue that is not explained clearly in this manual or you could not understand, please contact with our service department.

We thank you for choosing ECOSTAR brand.

Ecostar Gas Process Burners are manufactured in accordance with TS EN 746-2 standards.

This Operating Manual is an integral part of the burner and must be maintained in a plastic dossier and hung at a clearly visible place in the burner room.



TERMO ISI SİSTEMLERİ SAN.VE TİC.A.Ş.

Esentepe Mah.Milangaz Cad. No:75 K:3

Kartal Monumento Plaza

Kartal/İSTANBUL/TÜRKİYE

Tel: +90 216 442 93 00

Fax: +90 216 370 45 03

www.ecostar.com.tr









[e-mail:servis@ecostar.com.tr](mailto:servis@ecostar.com.tr)

CONTENTS

1. WARNINGS.....	3
1.1. Warning Symbols and Descriptions.....	3
1.2. General Safety Rules.....	4
2. TERMS OF WARRANTY.....	6
2.1. Out of Warranty Conditions.....	6
3. BURNER’S GENERAL FEATURES.....	7
3.1. Purpose of Use and Work Limits of Burners.....	7
3.2. Process Burner Components.....	8
4. GAS, FLUE GAS AND HEATING WATER SCHEMA.....	15
5. TECHNICAL DATA.....	16
5.1. Capacity and Technical Chart.....	16
5.2. Outer Dimensions.....	17
6. INSTALLATION.....	19
6.1. Burner Assembly Drawing.....	19
7. COMMISSIONING.....	20
7.1. Ignition and Ionizasyon System.....	20
7.2. General Controls.....	21
7.3. Combustion Adjustment.....	22
7.3.1. Gas Adjustment.....	22
7.3.1.1. VGD 20 4011 - 5011 Series Gas Valve.....	22
7.3.1.2. MB DLE Series Monoblock Gas Valve.....	22
7.3.1.3. MB ZRD(LE) 405 – 412 Series Gas Valve.....	24
7.4. Air pressure switch adjustment.....	25
7.5. Servomotor Adjustment.....	25
7.6. Pilot Ignition System.....	27
7.7. Program Relay.....	27
7.8. Function Controls and Adjustments.....	28
7.9. Final Checks.....	28
7.10. Gas Pass Equipment Required in Gas Line.....	29
8. MAINTENANCE.....	31
8.1. Monthly Maintenance.....	31
8.2. Seasonal Maintenance.....	31
9. TROUBLESHOOTING.....	32
10. PERIODICAL FLUE GAS MEASUREMENT REPORT.....	33
11. AFTER-SALES SERVICES.....	34
12. NOTES.....	35

1. WARNINGS

1.1. Warning Symbols and Descriptions

Symbols	Symbol Descriptions
	Important information and useful hints.
	Warning of danger to life or property.
	Warning of electrical voltage.
	Product handling information.
P_F	Impulse connection detecting combustion chamber pressure
P_L	Impulse connection detecting combustion air pressure
P_{BR}	Impulse connection detecting burner gas head
 CLEAN THE GAS BURNER. CLEAN GAS LINE. ЧИСТАЯ ЛИНИЯ ГАЗ.	"Clean the gas line" warning on gas line.
  	Carry in an upright position. Fragile Item. Protect against water.

1.2. General Safety Rules

- All personnel engaged in installation, disassembly, commissioning, operation, control, maintenance and repair should have received the necessary training and fully read and understood this manual.
- No changes that might damage the safety of the burner unit must be made by persons and/or organizations on the burner unit.
- All operation, commissioning and installation works (except for burning adjustment) should be carried out when the burner is not operating and after disconnecting the power supply. Noncompliance with these rules may lead to serious bodily injuries and even death by electrical shocks or uncontrolled flame formation.
- Repairs concerned with safety elements should be carried out only by the manufacturing company.
- The device should never be used by children, mentally handicapped and inexperienced persons.
- Children must not be allowed to play with the device.
- Keep the device away from explosive and flammable materials.
- Device must intake air, ventilation and air discharge holes must not be closed.



If you sense scent of gas;

- Shut down valves of all gas devices.
- Open all doors and windows.
- Do not turn on electric devices or do not turn them off if they are working.
- Do not use burner derived tools such as match and lighter.
- Inform the gas company.



Do not store any inflammable materials in boiler room.



Wear hearing protectors if there is noise in boiler room.



In case of fire or other emergency;

- Switch off the main switch
- Close the main fuel shut-off valve outside the plant.
- Take appropriate actions



Install burner firmly. Vibration may damage burner or its components.



Keep boiler doors closed while starting burner and during burner operation.



During the first commissioning of the burner or in case of any revision carried out in the electrical system or motor cables by any reason, direction of the fan rotation must certainly be checked by the authorized technical service.



For products that have not been commissioned or started more than 6 months, before activating the servomotor;

In gas and air dampers, servomotor and air damper connections must be checked to ensure that they are free running in spite of immobility and oil freezing.



In products used in high temperature oven applications; When the burners are not operated / are switched off, The air flaps must be set to remain in the half-open position, to prevent the burner components being damaged by hot air.



BURNER ROOM

Install the burner in a suitable room/floor with minimum external air openings and sufficient to ensure perfect combustion, in compliance with current regulations.

Never obstruct air openings of the burner room, burner fan intake vents or air ducts in order to prevent:

- a. The build up of toxic / explosive gas mixtures in the burner room,
- b. Combustion with insufficient air, resulting in hazardous, anti-economical and polluting operation.

The burner must be always protected from rain, snow and frost to prevent corrosion and paint deformations.

Keep the burner room clean and free of solid volatile substances, which could be sucked into the fan and clog the internal burner or combustion head air ducts.

2. TERMS OF WARRANTY

Main and auxiliary equipment and all components used in Ecostar gas process burners are guaranteed for 1 year by TERMO ISI SİST. A.Ş starting from the date of commissioning under the maintenance, adjustment, operating conditions and relevant mechanic, chemical and thermal effects explained herein.



Please note that this warranty is only valid if the device(s) is commissioned and maintained by our authorized services.



Our company reserves the right to make any modifications on the product and all instructions thereof for improvement purposes.

2.1. Out of Warranty Conditions

- Any damage arising out of or in relation to customers' non-compliance to their responsibilities with regards to installation, commissioning, operation and maintenance,
- Any damage arising out of or in relation to commissioning, repairs and maintenance carried out by unauthorized services,
- Any damage that may occur during transportation or storage of the product,
- Not preserving the product in its original packaging until the installation stage,
- Incorrect and poor electrical connections, Failures due to incorrect voltage applications, frequent repetition of voltage fluctuations,
- Any damage that may occur as a result of incorrect fuel usage or, foreign substances in the fuel used or using of the product without any fuel,
- Any damage that may occur due to foreign particles entered into the product during installation and operation,
- Failures due to incorrect device selection,
- Any damage to unit due to natural disasters,
- Devices without any warranty certificates,
- Warranty Certificates without the stamp and signature of the authorized dealer or service,
- Devices with any falsification on the warranty certificate or without an original serial number.
- The risks during transportation of device under the responsibility of customer belong to the customer.
- Presence of misuse faults are indicated in the reports issued by authorized service stations or our authorized agent, dealer, representative or our factory in case of unavailability of authorized service stations.
- Customers may apply consumer protection arbitrator committee with regards to this report and request for an expert report.

3. BURNER'S GENERAL FEATURES

ECOSTAR gas process burners are manufactured such that they operate in gas pressure at 15%...+10% of nominal voltage, between the ambient temperature range of -15°C...+60°C and declared capacity and boiler pressure ranges with Natural Gas and Liquid Petrol Gas.

3.1. Purpose of Use and Work Limits of Burners

- This product works at any load value equivalent to its max. capacity or covered by its capacity range;
 - High temperature industrial appliances.
 - In direct and indirect hot air generators,
 - -15 °C...+60 °C ambient temperature range,
 - In accordance with the model, 1N 230 VAC / 3N 380VAC 50 Hz supply voltage (-%15 ... + 10%)
 - Max. 95% relative humidity,
 - In well-ventilated open and closed spaces compatible with protection class IP 40.
 - Operation with Natural gas and LPG.



This device must never be operated with open flame!

3.2. Process Burner Components

FPB 80

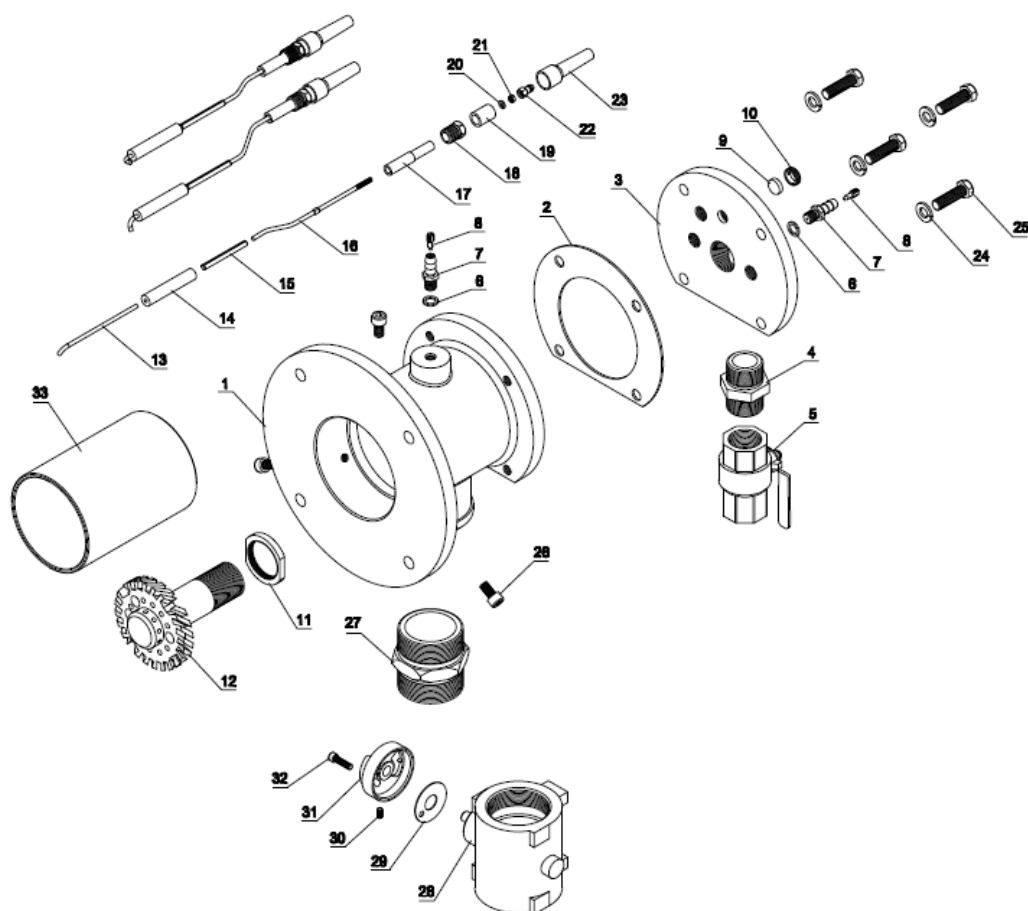

Nu.	Part Name	Nu.	Part Name
1	Body	18	Plug reduction
2	Gasket	19	Plug porcelain
3	Gas intake flange	20	Washer
4	Nipple	21	Nut
5	Ball valve	22	Plug head
6	Washer	23	Ignition ionization head
7	Purger	24	Washer
8	Purger needle	25	Bolt
9	Bulls eye	26	Bolt
10	Bulls eye housing	27	Nipple
11	Diffuser adjusting nut	28	Klappe complete
12	Diffuser	29	Klappe label
13	Ionization electrode wire	30	Stay Bolt
14	Porcelain	31	Klappe indicator
15	Pin	32	Bolt
16	Electrode wire	33	Flame tube
17	Plug porcelain		

FPB 200

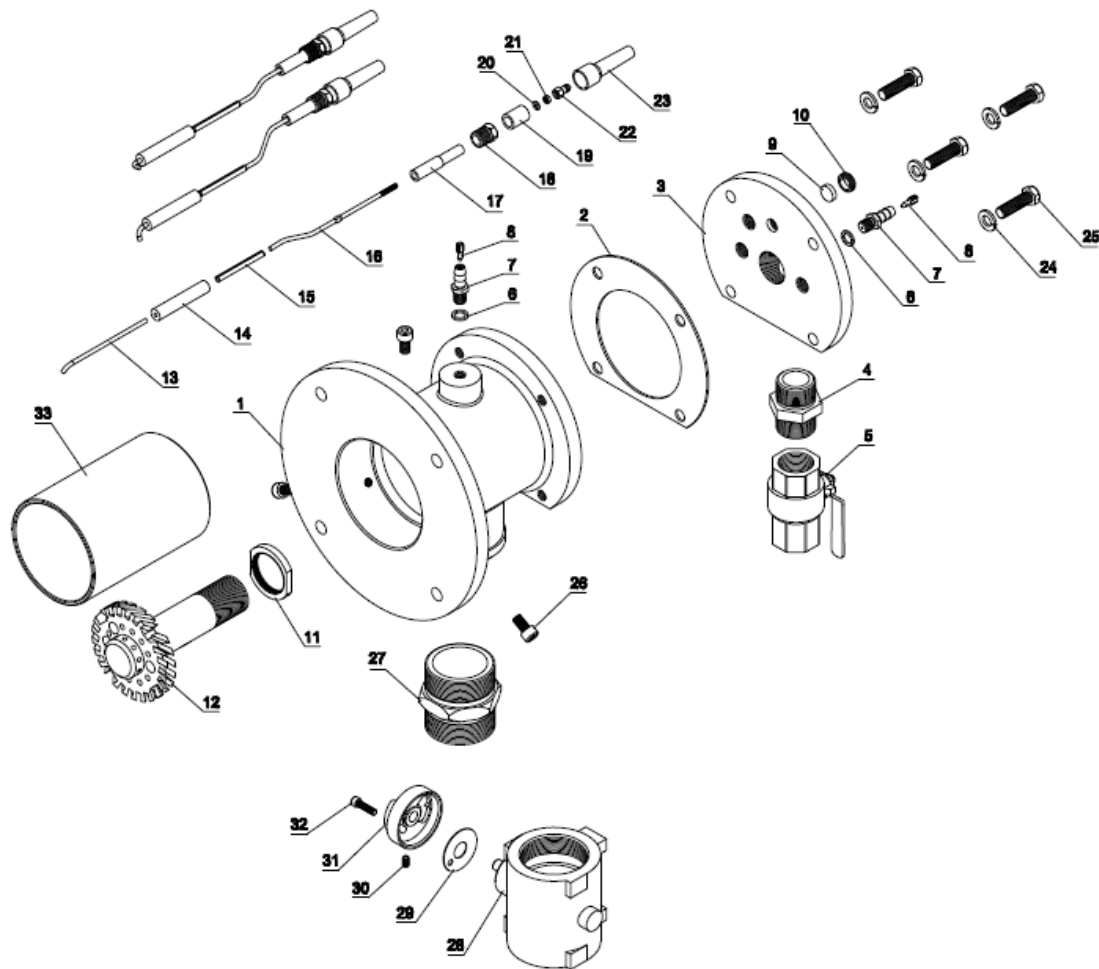

Nu.	Part Name	Nu.	Part Name
1	Body	18	Plug reduction
2	Gasket	19	Plug porcelain
3	Gas intake flange	20	Washer
4	Nipple	21	Nut
5	Ball valve	22	Plug head
6	Washer	23	Ignition ionization head
7	Purger	24	Washer
8	Purger needle	25	Bolt
9	Bulls eye	26	Bolt
10	Bulls eye housing	27	Nipple
11	Diffuser adjusting nut	28	Klappe complete
12	Diffuser	29	Klappe label
13	Ionization electrode wire	30	Stay Bolt
14	Porcelain	31	Klappe indicator
15	Pin	32	Bolt
16	Electrode wire	33	Flame tube
17	Plug porcelain		

FPB 400

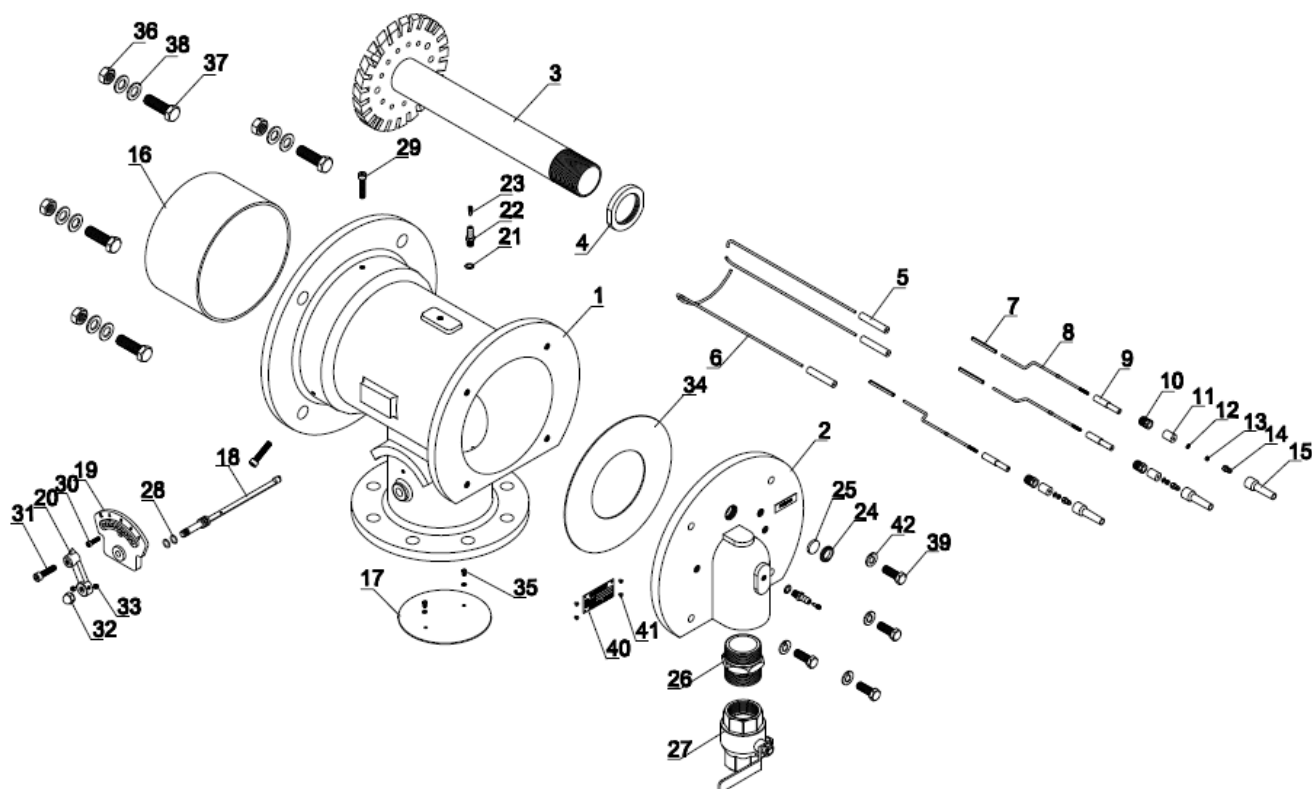

Nu.	Part Name	Nu.	Part Name
1	Body	22	Purger
2	Gas intake flange	23	Purger needle
3	Diffuser	24	Bulls eye housing
4	Nut	25	Bulls eye
5	Porcelain	26	Nipple
6	Ionization electrode wire	27	Ball valve
7	Pin	28	Washer
8	Plug electrode wire	29	Bolt
9	Plug porcelain	30	Bolt
10	Plug reduction	31	Bolt
11	Plug porcelain	32	Nut
12	Washer	33	Stay Bolt
13	Nut	34	Gasket
14	Plug head	35	Bolt
15	Ignition ionization head	36	Nut
16	Flame tube	37	Bolt
17	Klappe sheet	38	Pul
18	Klappe shaft	39	Bolt
19	Klappe indicator	40	Capacity label
20	Klappe indicator bar	41	Rivet
21	Washer	42	Washer

FPB 550

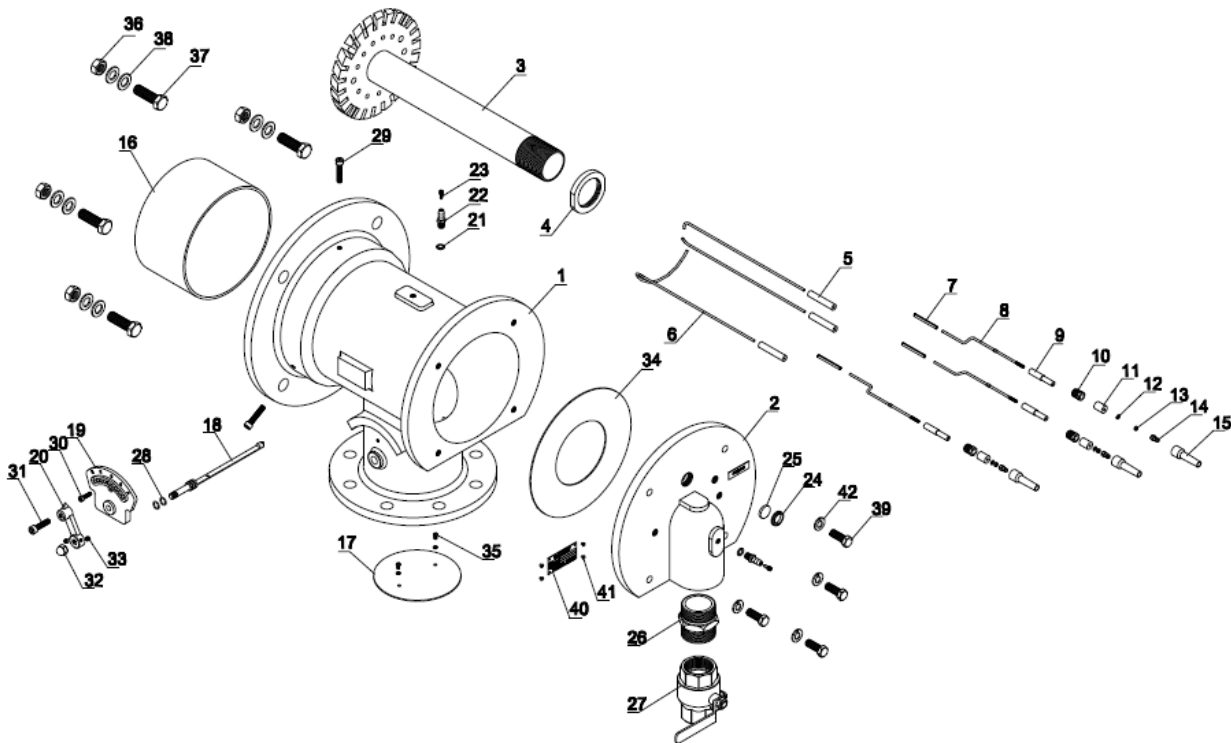

Nu.	Part Name	Nu.	Part Name
1	Body	22	Purger
2	Gas intake flange	23	Purger needle
3	Diffuser	24	Bulls eye housing
4	Nut	25	Bulls eye
5	Porcelain	26	Nipple
6	Ionization electrode wire	27	Ball valve
7	Pin	28	Washer
8	Plug electrode wire	29	Bolt
9	Plug porcelain	30	Bolt
10	Plug reduction	31	Bolt
11	Plug porcelain	32	Nut
12	Washer	33	Stay Bolt
13	Nut	34	Gasket
14	Plug head	35	Bolt
15	Ignition ionization head	36	Nut
16	Flame tube	37	Bolt
17	Klappe sheet	38	Pul
18	Klappe shaft	39	Bolt
19	Klappe indicator	40	Capacity label
20	Klappe indicator bar	41	Rivet
21	Washer	42	Washer

FPB 870 – FPB 1200

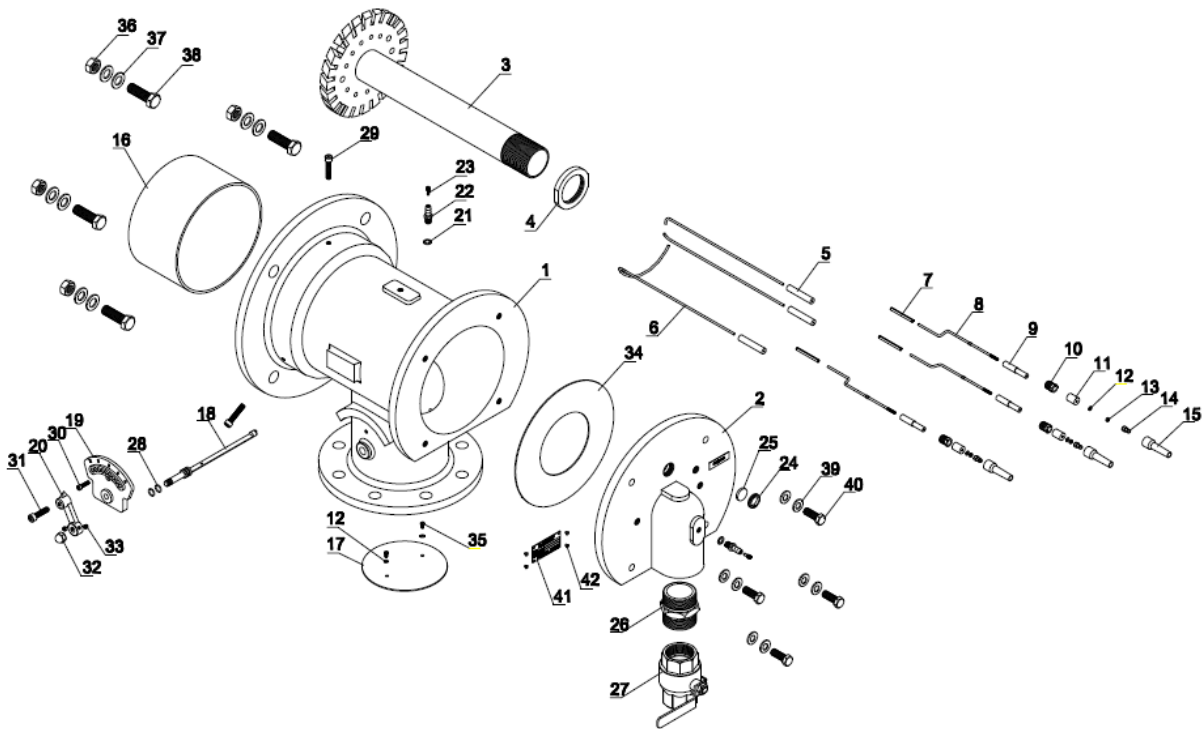

Nu.	Part Name	Nu.	Part Name
1	Body	22	Purger
2	Gas intake flange	23	Purger needle
3	Diffuser	24	Bulls eye housing
4	Nut	25	Bulls eye
5	Porcelain	26	Nipple
6	Ionization electrode wire	27	Ball valve
7	Pin	28	Washer
8	Plug electrode wire	29	Bolt
9	Plug porcelain	30	Bolt
10	Plug reduction	31	Bolt
11	Plug porcelain	32	Nut
12	Washer	33	Stay Bolt
13	Nut	34	Gasket
14	Plug head	35	Bolt
15	Ignition ionization head	36	Nut
16	Flame tube	37	Washer
17	Klappe sheet	38	Bolt
18	Klappe shaft	39	Washer
19	Klappe indicator	40	Bolt
20	Klappe indicator bar	41	Capacity label
21	Washer	42	Rivet

FPB 1600- FPB 2000 – FPB 2500

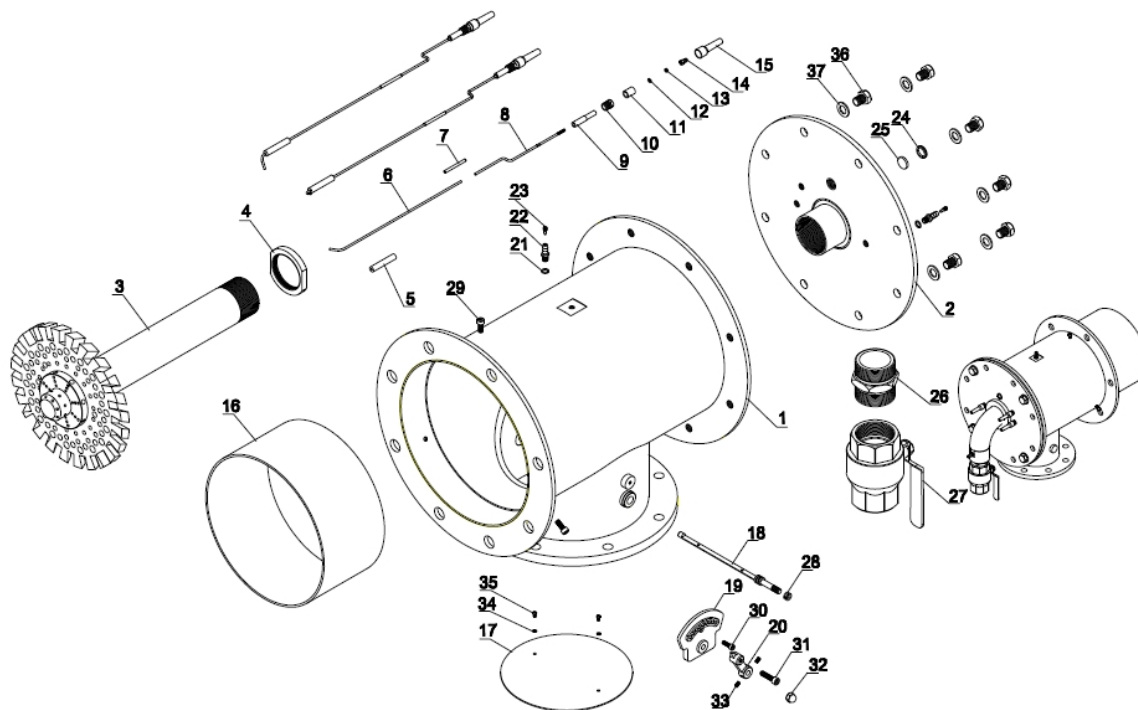

Nu.	Part Name	Nu.	Part Name
1	Body	20	Klappe indicator bar
2	Gas intake flange	21	Washer
3	Diffuser	22	Purger
4	Nut	23	Purger needle
5	Porcelain	24	Bulls eye housing
6	Ionization electrode wire	25	Bulls eye
7	Pin	26	Nipple
8	Plug electrode wire	27	Ball valve
9	Plug porcelain	28	Washer
10	Plug reduction	29	Bolt
11	Plug porcelain	30	Bolt
12	Washer	31	Bolt
13	Nut	32	Nut
14	Plug head	33	Stay Bolt
15	Ignition ionization head	34	Washer
16	Flame tube	35	Bolt
17	Klappe sheet	36	Bolt
18	Klappe shaft	37	Washer
19	Klappe indicator		

FPB 3500 – FPB 5000

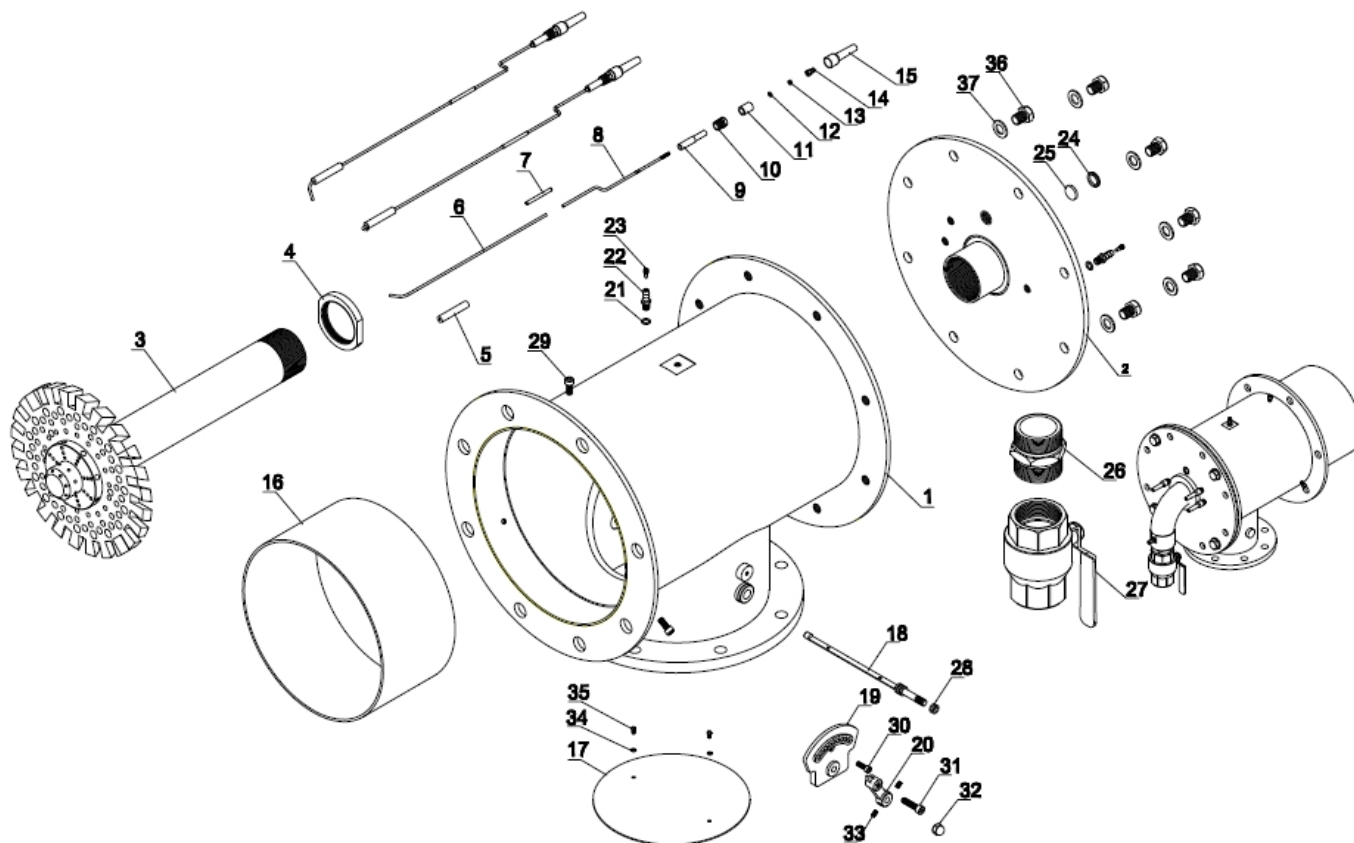

Nu.	Part Name	Nu.	Part Name
1	Body	20	Klappe indicator bar
2	Gas intake flange	21	Washer
3	Diffuser	22	Purger
4	Nut	23	Purger needle
5	Porcelain	24	Bulls eye housing
6	Ionization electrode wire	25	Bulls eye
7	Pin	26	Nipple
8	Plug electrode wire	27	Ball valve
9	Plug porcelain	28	Washer
10	Plug reduction	29	Bolt
11	Plug porcelain	30	Bolt
12	Washer	31	Bolt
13	Nut	32	Nut
14	Plug head	33	Stay Bolt
15	Ignition ionization head	34	Washer
16	Flame tube	35	Bolt
17	Klappe sheet	36	Bolt
18	Klappe shaft	37	Washer
19	Klappe indicator		

4. GAS, FLUE GAS AND HEATING WATER SCHEMA

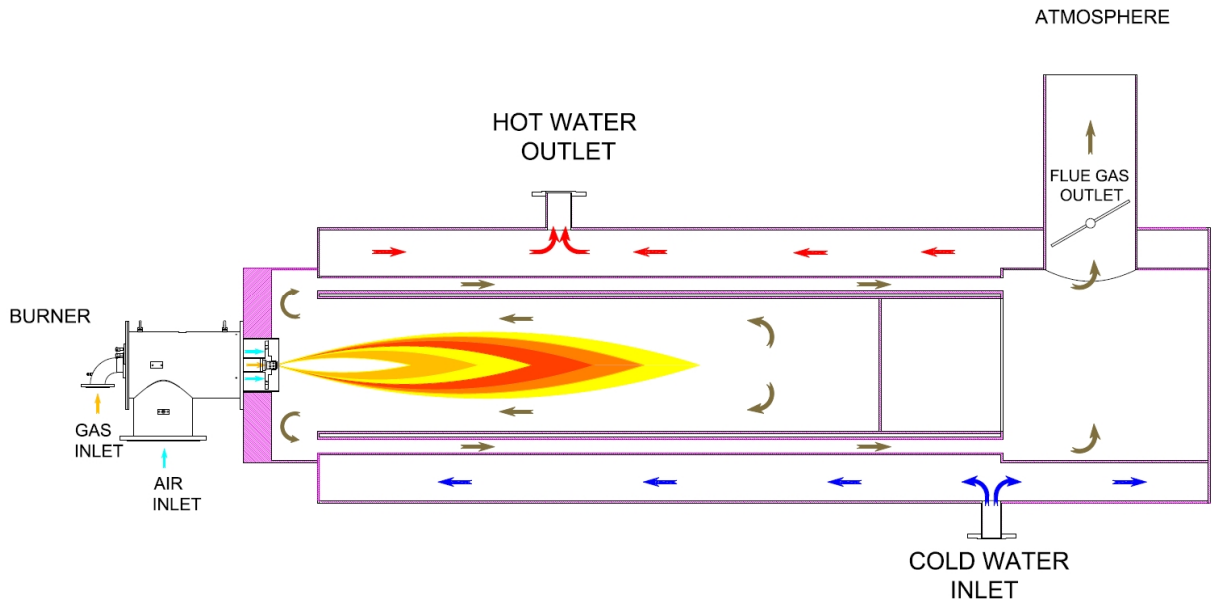

5. TECHNICAL DATA

5.1. Capacity and Technical Chart

FPB PROCESS BURNERS									
	CAPACITY		CAPACITY		NATURAL GAS CONSUMPTION		LPG GAS CONSUMPTION		FAN RATE
	Min.	Max.	Min.	Max.	Min.	Max.	Min.	Max.	
	Kcal/h		kW		Nm ³ /h		Nm ³ /h		Nm ³ /h
FPB 20	4.000	20.000	4,7	23,3	0,5	2,4	0,2	0,9	30
FPB 80	16.000	80.000	18,6	93,0	1,9	9,7	0,7	3,6	150
FPB 200	40.000	200.000	46,5	232,6	4,8	24,2	1,8	8,9	350
FPB 300	60.000	300.000	69,8	348,8	7,3	36,4	2,7	13,3	500
FPB 400	80.000	400.000	93,0	465,1	9,7	48,5	3,6	17,8	650
FPB 550	110.000	550.000	127,9	639,5	13,3	66,7	4,9	24,4	900
FPB 870	174.000	870.000	202,3	1011,6	21,1	105,5	7,7	38,7	1.400
FPB 1200	240.000	1.200.000	279,1	1395,3	29,1	145,5	10,7	53,3	2.000
FPB 1600	320.000	1.600.000	372,1	1860,5	38,8	193,9	14,2	71,1	2.500
FPB 2000	400.000	2.000.000	465,1	2325,6	48,5	242,4	17,8	88,9	3.100
FPB 2500	500.000	2.500.000	581,4	2907,0	60,6	303,0	22,2	111,1	4.000
FPB 3500	700.000	3.500.000	814,0	4069,8	84,8	424,2	31,1	155,6	5.500
FPB 5000	1.000.000	5.000.000	1162,8	5814,0	121,2	606,1	44,4	222,2	7.800

H_u Natural Gas =8250 kcal/Nm³

H_u LPG=22500 kcal/Nm³

5.2. Outer Dimensions

FPB 20 - 80 - 200

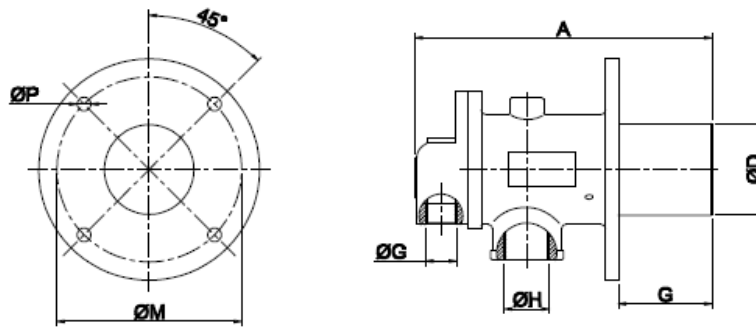

FPB 300 - 400 - 550 - 870 - 1200

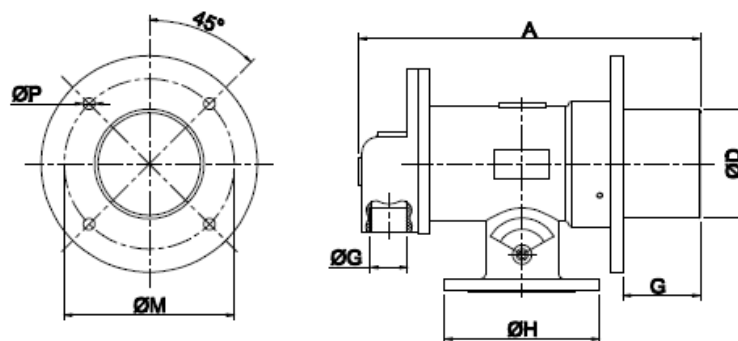

FPB 1200 - 1600 - 2000 - 2500

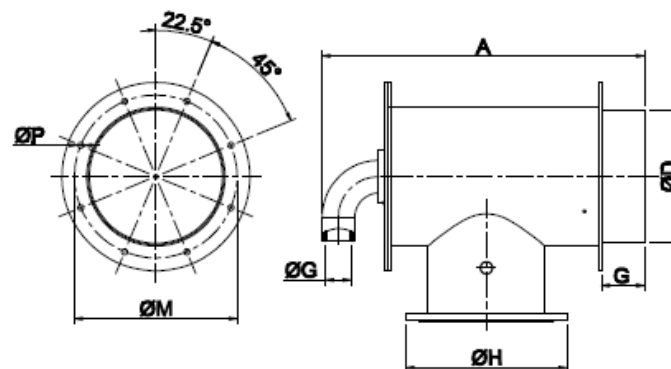

FPB 3500 - 5000

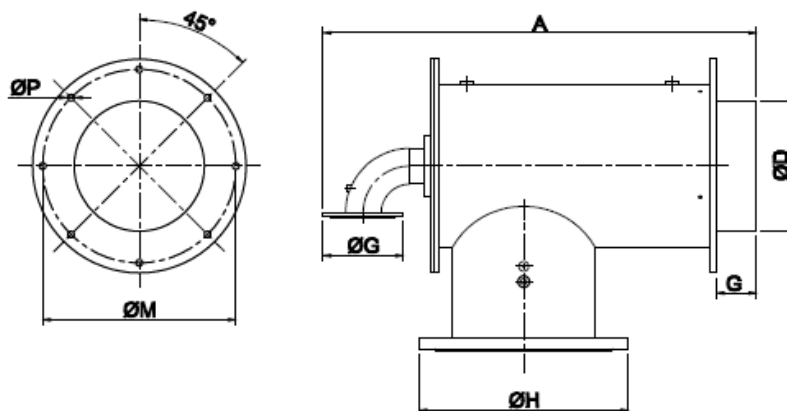

FPB BURNER		A	G	ØD	ØH	ØDG	ØM	ØP
		mm	mm	mm	-	-	mm	mm
CAST BODY	FPB 20	270	100	41	R 3/4"	R 1/2"	90	9
	FPB 80	350	100	69	R 1 1/2"	R 1"	108	12
	FPB 200	365	100	100	R 2"	R 1"	198	12
	FPB 300	490	100	140	NW 80	R 1 1/2"	220	15
	FPB 400	490	100	140	NW 80	R 1 1/2"	220	15
	FPB 550	545	100	175	NW 100	R 1 1/2"	243	15
	FPB 870	620	100	220	NW 150	R 2"	330	17
	FPB 1200	620	100	220	NW 150	R 2"	330	17
STEEL BODY	FPB 1600	800	100	308	NW 250	R 2"	380	14
	FPB 2000	800	100	308	NW 250	R 2"	380	14
	FPB 2500	800	100	308	NW 250	R 2 1/2"	380	14
	FPB 3500	1080	100	322	NW 350	NW 80	480	17
	FPB 5000	1235	100	322	NW 350	NW 100	480	17

6. INSTALLATION

6.1. Burner Assembly Drawing

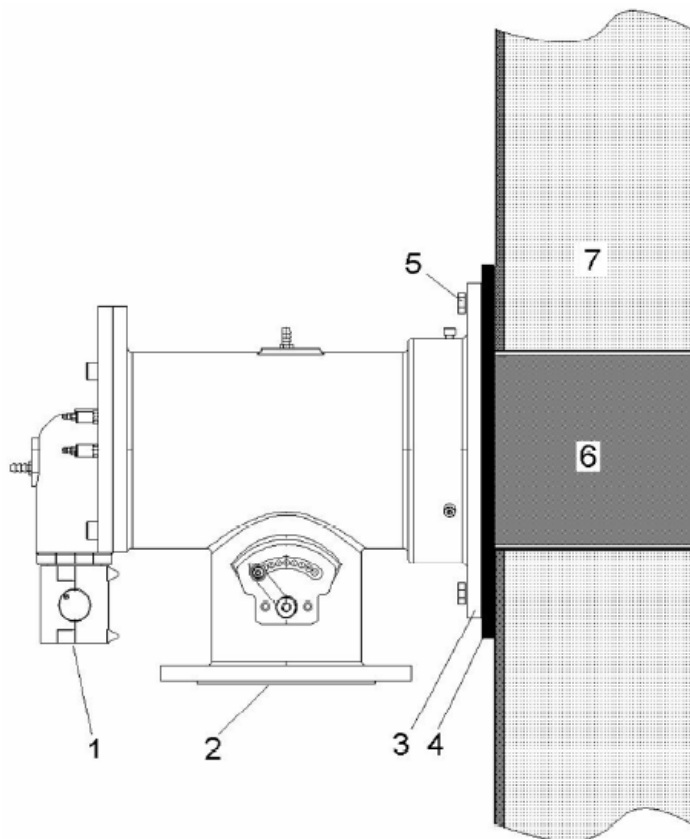

1. Gas Intake
2. Air Inlet
3. Connecting Flange
4. Insulation Material (Gasket)
5. Installation Bolt
6. Flame Tube
7. Combustion Chamber Refractory



Sealing between the combustion chamber and burner must be ensured



Device must be shipped in original packaging!



Do not lift the device holding from servomotor, gas valve, impulse pipes or pressure switch during installation!



Clean the inside of fuel line thoroughly before installing the burner to the fuel line. Any damage that may occur due to solid objects and metal particles from the fuel line shall not be covered by our company.

7. COMMISSIONING

7.1. Ignition and Ionization System

Combustion Head for Low Temperature Application

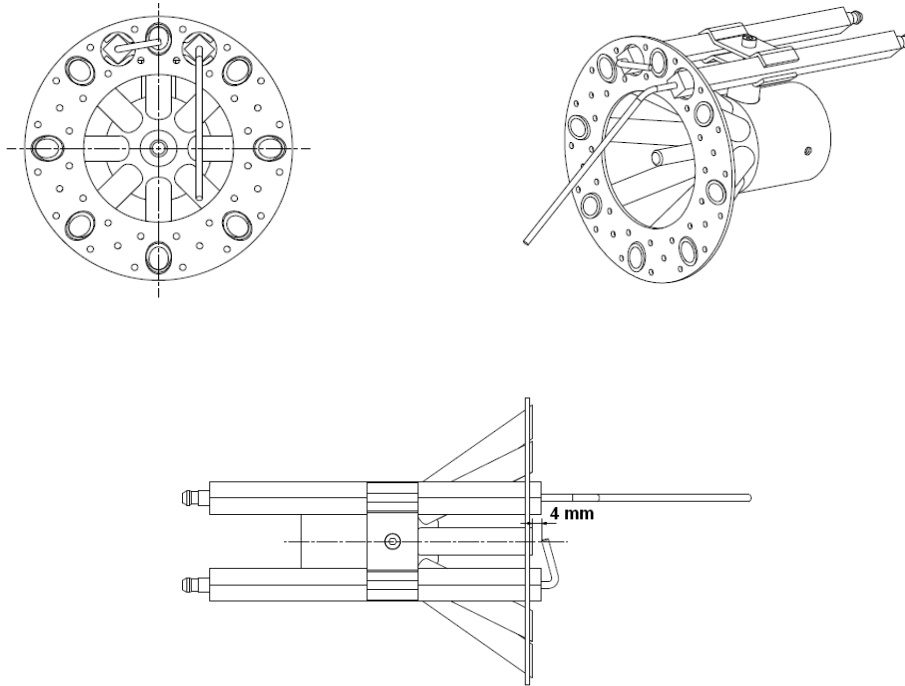

Combustion Head for High Temperature Application

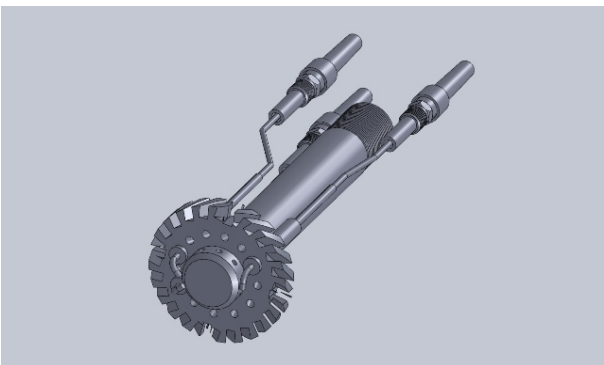

Electrical connection

Perform electrical connections according to the diagram provided with the burner. Follow general security rules during installation of electric wiring and making connections. Connect the earthing terminal in electric panel to the earthing installation.

7.2. General Controls



Make sure to perform the following controls before commissioning the burner.

- Ø Has heat demand been formed?
- Ø Are the thermostat and other thermo-elements for control purposes working properly?
- Ø Are the electrical connections correct?
- Ø Is there gas?
- Ø Is there sufficient air in boiler room (ventilation section $\text{cm}^2 = \text{boiler capacity kW} \times 7$)
- Ø Has the boiler been installed correctly?
- Ø Has the air of the gas line been removed? Has a sealing test been made?

Operation of one-stage burner

- Ø Open the main gas valve, check the gas pressure from the manometer at the valve. (max.300 mbar)
- Ø Check the boiler thermostat or pressure switch settings.
- Ø Bring the operating switch on the burner panel to position 1.
- Ø Burner fan motor will be activated.
- Ø Ignition will take place at the end of pre-purge process.
- Ø 3 sec. later, the gas valve will be opened and combustion will occur.
- Ø Flame control system (ionization) will start flame control.
- Ø Burner is deactivated after the required capacity is formed.

Operation of two-stage burner

- Ø Open the main gas valve, check the gas pressure from the manometer at the valve. (max.300 mbar)
- Ø Check the boiler thermostat or pressure switch settings.
- Ø Bring the operating switch on the burner panel to position 2.
- Ø Burner fan motor will be activated.
- Ø Ignition will take place at the end of pre-purge process.
- Ø 3 sec. later, the gas valve will be opened and combustion will occur.
- Ø Flame control system (ionization) will start flame control.
- Ø Burner will switch to the second stage (max. capacity) according to the heat requirement.
- Ø Burner is deactivated after the required capacity is formed.

Operation of a modulating burner

- Ø Open the main gas valve; check max 300 mbar gas pressure from the manometer.
- Ø Open operating switch on the burner panel.
- Ø Switch on the modulating control switch.
- Ø Switch automatic-hand switch to automatic.
- Ø Check the temperature and pressure set values from the modulating control unit.
- Ø Ignition will take place at the end of pre-purge process.
- Ø 3 sec. later, the gas valve will be opened and combustion will occur.
- Ø Flame control system (ionization) will start flame control.
- Ø In modulating burner, the burner goes into max. capacity according to the signal from the modulating control unit.
- Ø When the capacity increases, modulating control unit will switch the burner to min. capacity.
- Ø If the boiler water temperature or steam pressure increases despite the operation of burner with min. capacity, the modulating control unit will stop the burner.

7.3. Combustion Adjustment

7.3.1. Gas Adjustment

Follow the instructions of the valve manufacturer during installation, dismantling and adjustment of the gas valve

7.3.1.1. VGD 20 4011 - 5011 Series Gas Valve

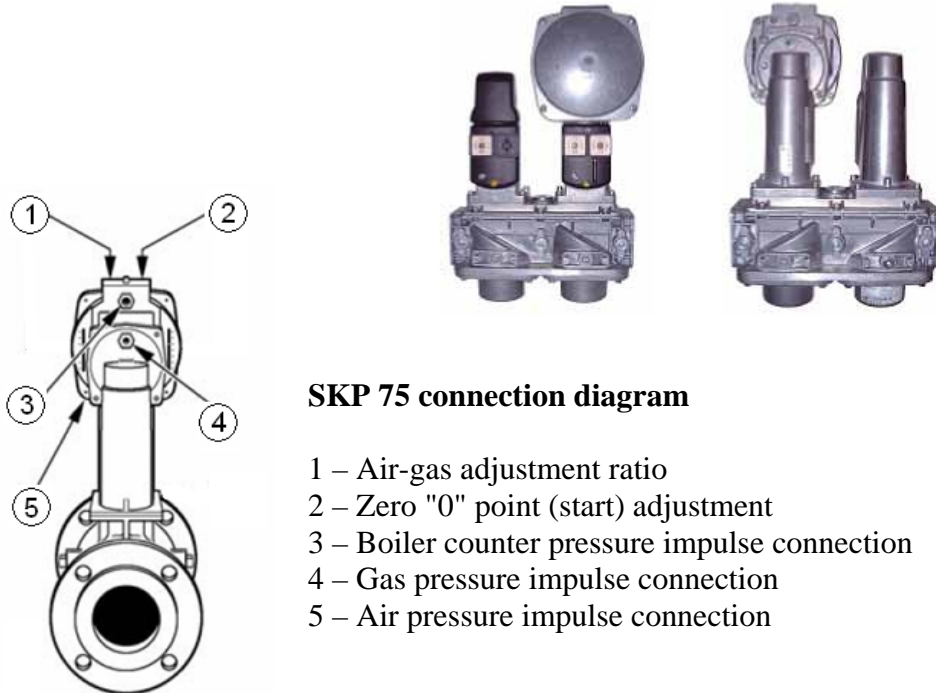

SKP 75 connection diagram

- 1 – Air-gas adjustment ratio
- 2 – Zero "0" point (start) adjustment
- 3 – Boiler counter pressure impulse connection
- 4 – Gas pressure impulse connection
- 5 – Air pressure impulse connection

7.3.1.2. MB DLE Series Monoblock Gas Valve

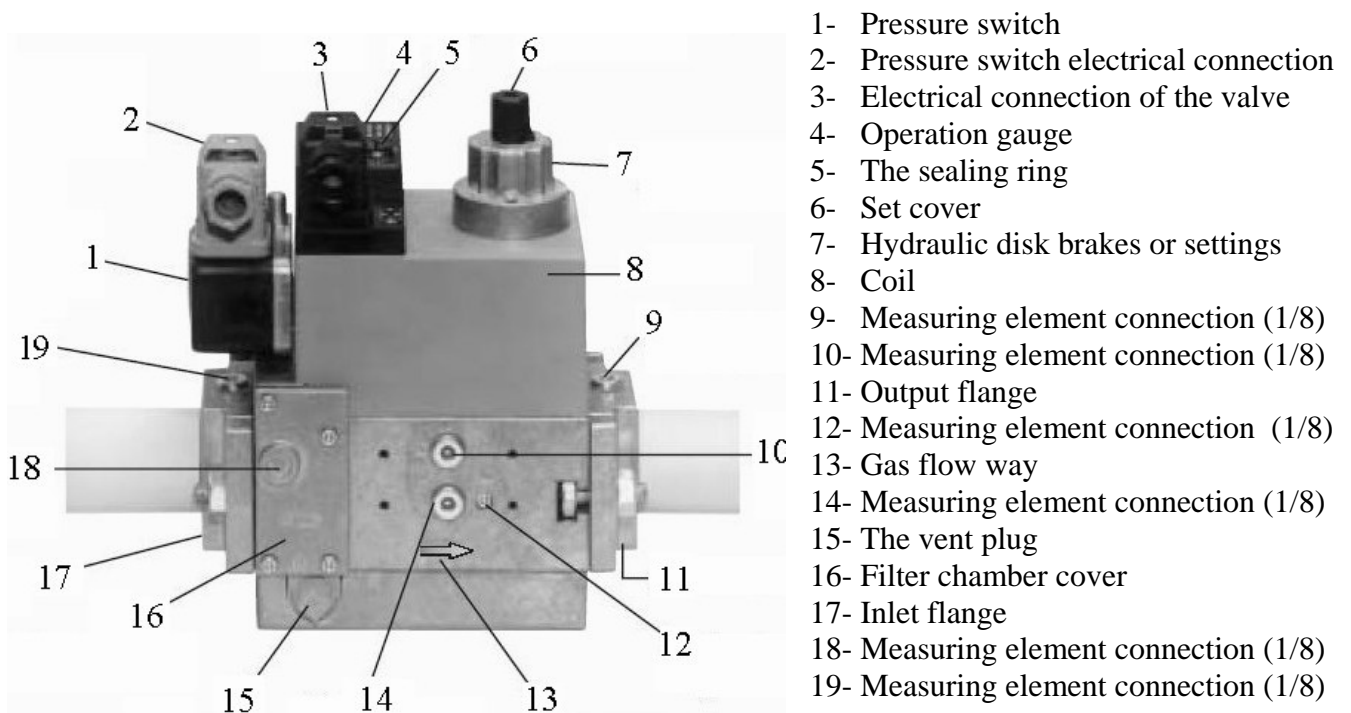

- 1- Pressure switch
- 2- Pressure switch electrical connection
- 3- Electrical connection of the valve
- 4- Operation gauge
- 5- The sealing ring
- 6- Set cover
- 7- Hydraulic disk brakes or settings
- 8- Coil
- 9- Measuring element connection (1/8)
- 10- Measuring element connection (1/8)
- 11- Output flange
- 12- Measuring element connection (1/8)
- 13- Gas flow way
- 14- Measuring element connection (1/8)
- 15- The vent plug
- 16- Filter chamber cover
- 17- Inlet flange
- 18- Measuring element connection (1/8)
- 19- Measuring element connection (1/8)

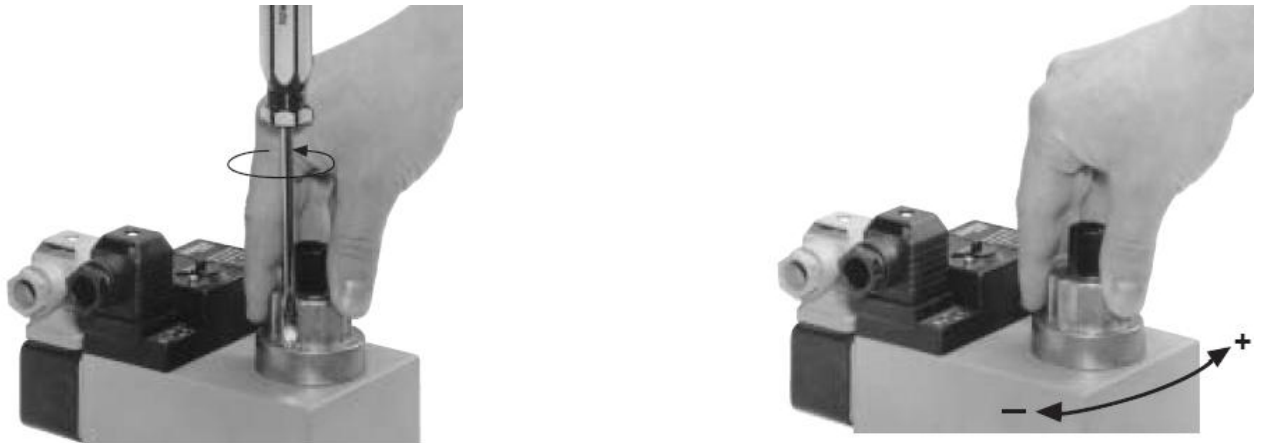

- Consider the below torque values for bolts tightened on the valve.
- Tighten flange bolts according to cross ordering and use proper tools.
- Sealing and function check must be performed if the valve is dismantled and re-installed over the line due to any reason.
- Before dismantling the valve from the line, you can perform filter replacement according to the below order.
 - o Cut off the gas flow (turn off the ball valve)
 - o Remove the 4 bolts (1,2,3,4) on the cover seen in the picture and take out the cover (5).
 - o Take the filter cartridge (6) out of its socket and replace with a new one
 - o Close the cover and tighten the bolts. In frequently performed filter replacement operations, use M4x14 bolt instead of self-tapping bolts used for fixing the cover.
 - o Perform sealing and function control

Max. torque values;

M 4	M 5	M 6	M 8	G 1/8	G 1/4	G 1/2	G 3/4
2,5 Nm	5 Nm	7 Nm	15 Nm	5 Nm	7 Nm	10 Nm	15 Nm

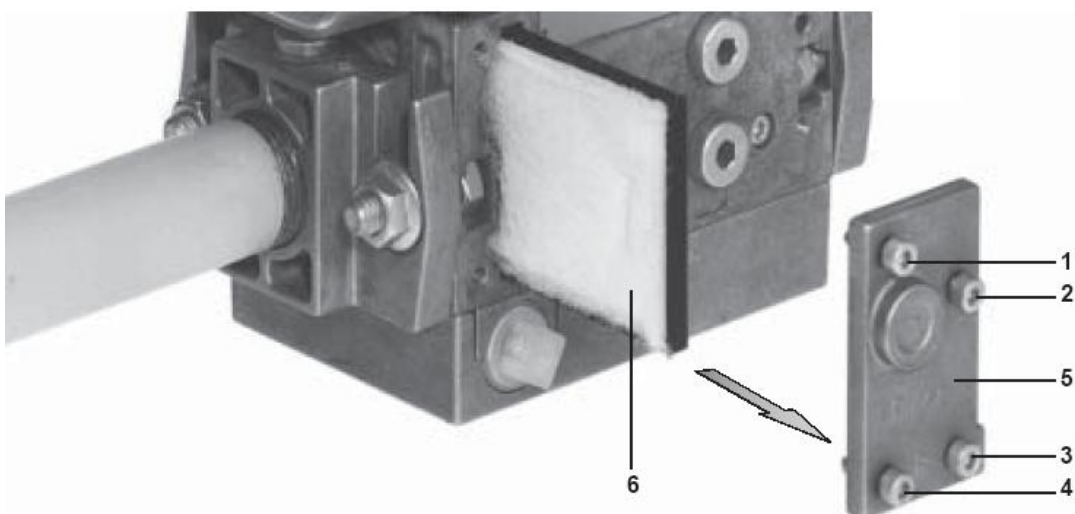

7.3.1.3. MB ZRD(LE) 405 – 412 Series Gas Valve

GasMultiBloc[®]
Combined regulator and
safety shut-off valves
Two-stage function

MB-ZRD(LE) 405 - 412 B01

DUNGS[®]
Combustion Controls

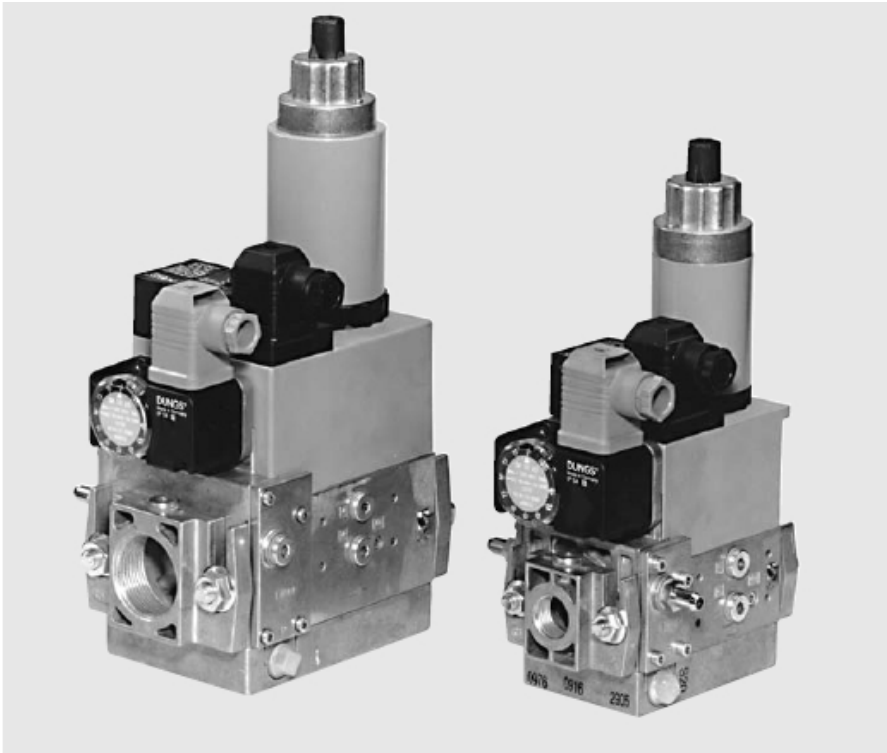

Technical description

The DUNGS GasMultiBloc[®] integrates filter, regulator, valves and pressure switches in one compact fitting.

- Dirt trap: microfilter
- One regulator and two main valves: B01
- One one-stage valve and one two-stage valve
- One valve is fast opening, one valve is slow or fast opening
- Solenoid valves up to 360 mbar (36 kPa) as per DIN EN 161 Class A Group 2
- Sensitive setting of output pressure by proportional regulator as per DIN EN 88 Class A Group 2
- High flow rates with low pressure drop
- DC solenoid drive interference degree N
- Main volume restrictor and partial volume restrictor at valve V2
- Hydraulic opening delay
- Flange connections with pipe threads as per ISO 7/1
- Simple mounting, compact, light-weight

The modular system permits individual solutions by using external ignition gas tap in connection with separately controlled valves, by adding a valve proving system, mini/maxi pressure switches, pressure limiters, limit switch and closing stroke limiter at valve V2, regulator blocking for liquid gas applications.

Application

The modular system permits individual solutions in gas safety and regulator engineering. Suitable for gases of families 1, 2, 3 and other neutral gaseous media.

Approvals

EC type test approval as per EC Gas Appliance Directive:
MB-ZR...405-412 B01 CE-0085 AP 3156
EC type test approval as per EC Pressure Equipment Directive:
MB-ZR...405-412 B01 CE0036
Approvals in other important gas consuming countries.

7.4. Air pressure switch adjustment

While the burner is working without any problem, the air pressure switch is adjusted to desired minimum pressure as follows.

- Ø Unscrew the screw of the transparent cover and remove the cover.
- Ø Turn the adjustment wheel in the direction to increase the pressure, note the pressure value at which the burner is failed.
- Ø Set the pressure switch to a value 1 mbar lower than the pressure value at which the burner failed and close the pressure switch lid.
- Ø It is recommended that this adjustment is carried out when the burner is at minimum load.



7.5. Servomotor Adjustment

Ø SQN70

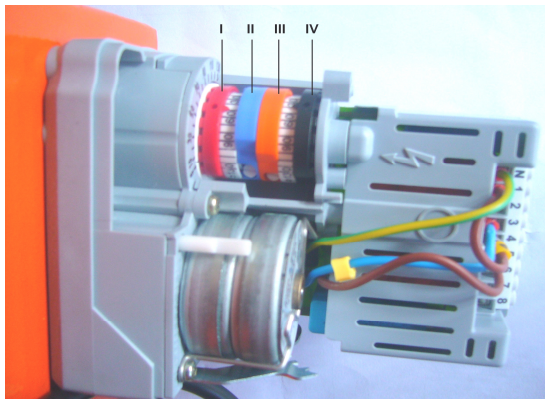

At Two-stage Burners;

- I. Red Cam: Adjusts 2nd level max. air.
- II. Blue Cam: Resets the clamp.
- III. Orange Cam: Adjusts 1st level min. air.
- IV. Black Cam: Adjusts 2nd level valve opening degree.

At Modulating Burners;

- I. Red Cam: Performance max. air adjustment.
- II. Blue Cam: Resets the clamp.
- III. Orange Cam: Performs min. air adjustment.
- IV. Black Cam: Not used.

Ø SQM10



- I. Cam: Opening
- II. Cam: Resets the clamp
- III. Cam: Commissioning air
- IV. V.VI. and VII. Cam not used

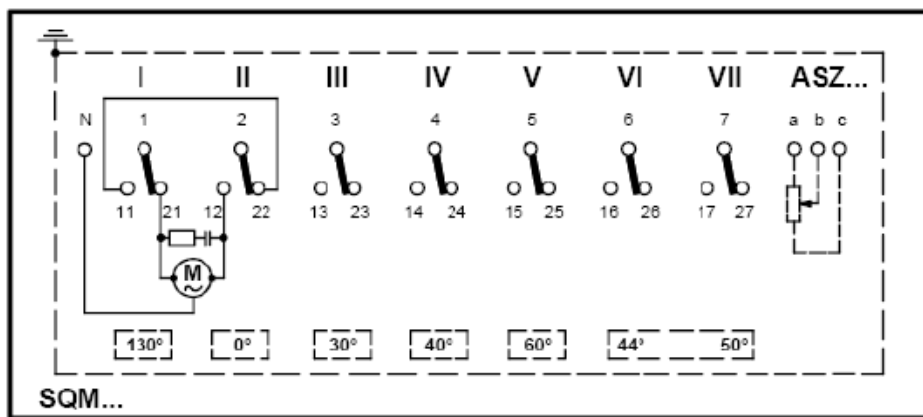
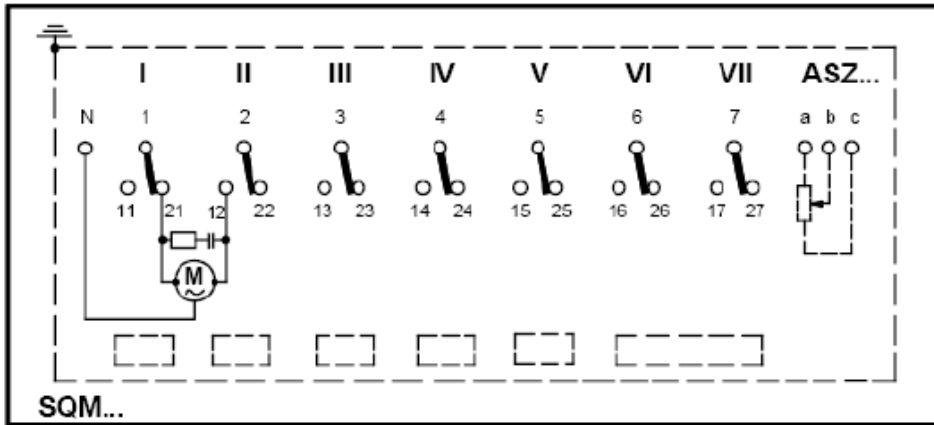

7812a02/1097

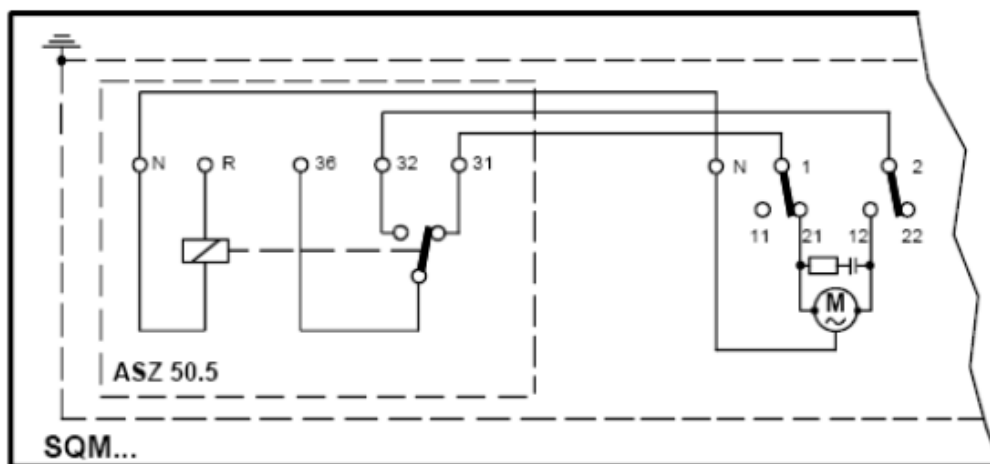

7812a03/1097



Do not open servomotor. Do not interfere with. It may damage servomotor or change burner settings.



Burner's actuators should not be installed closer to high temperature zones, max allowed ambient temperature should be 60 °C for actuator's operation safety

7.6. Pilot Ignition System

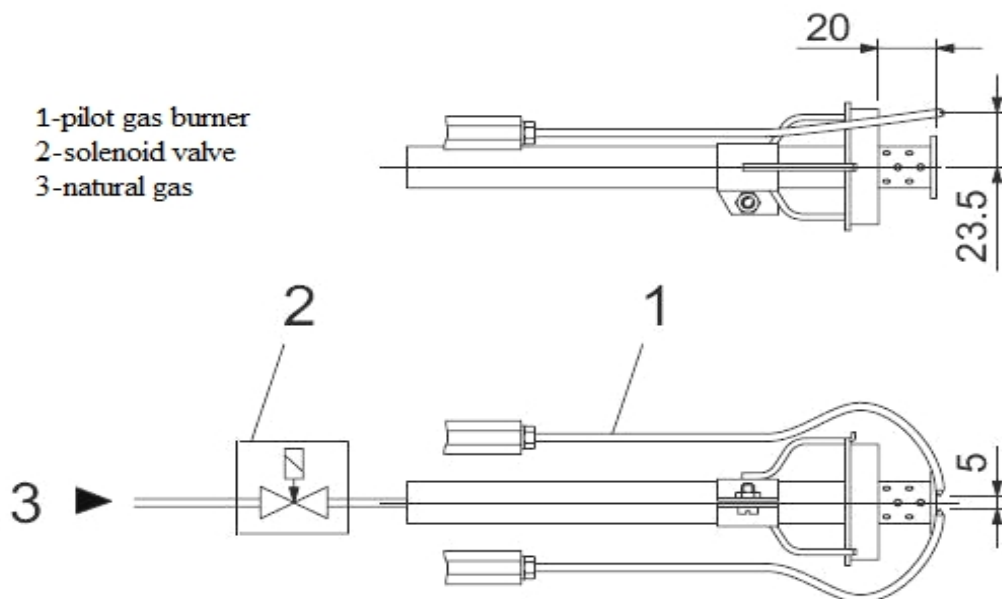

Pilot gas burner inlet pressure P_{max} = 200 mbar

7.7. Program Relay

LFL 1.32



LME 22



- Ø Yellow led on: Indicates that the burner is making pre-purge.
- Ø Yellow led flashing: Indicates that the burner is igniting.
- Ø Green led flashing: Indicates poor combustion.
- Ø Red led on: Indicates burner malfunction.



Press and hold the light button for 2 sec. to reset the program relay.

7.8. Function Controls and Adjustments

- Ø **Operation testing:** If the burner switch is turned on and safety circuit is complete (gas pressure switch, thermostat, water level gauge, lower pressure gas pressure switch, upper pressure gas pressure switch, gas leakage control device), turn on the ball valve, burner will start working and turn off the gas valve. Program operation of the relay must be normal until ignition time. During opening of the magnetic valve, gas pressure will drop down and the lower pressure switch will stop the burner for safety.
- Ø When the ball valve is opened again, gas pressure will increase and lower pressure switch will trip in from safety position and the burner will automatically start operating.
- Ø Disconnect the ionization circuit or remove the photocell when the burner is operating: Burner will give a fault after burning up.
- Ø Increase the value of the air pressure thermostat: Burner starts operating, however it should give a fault due to the insufficiency of air pressure.



Magnetic valves must not be energized during pre-purge. Check if valves are in closed position!

7.9. Final Checks

- Ø Switch of all purges after completion of all necessary measurements.
- Ø Start and stop the burner at least 3 times to check the operation of the program.
- Ø Make sure that all safety circuits on the burner and boiler operate properly before leaving the installation site.

7.10. Gas Pass Equipment Required in Gas Line

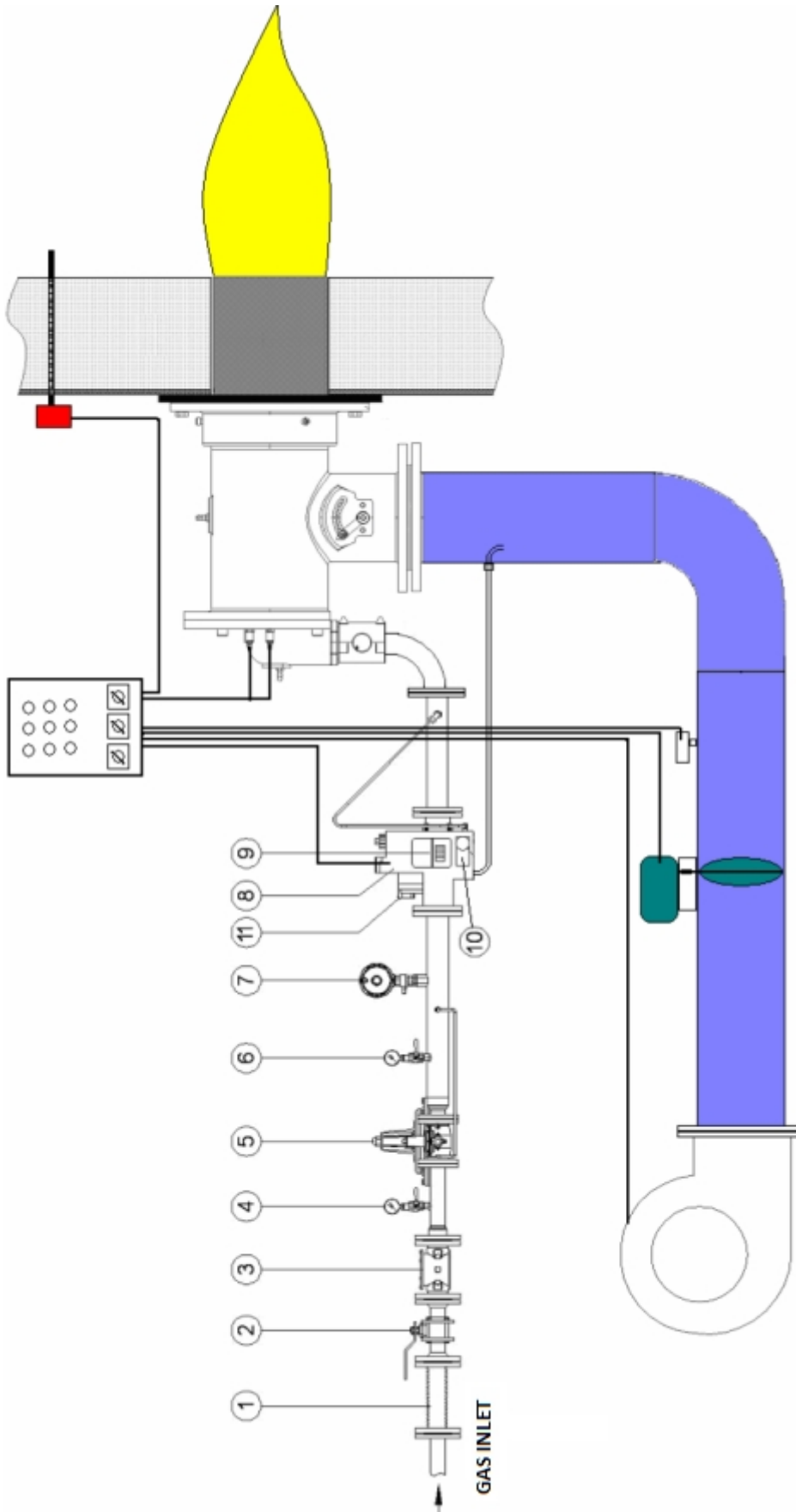

Pe < 300 mbar Q<1200kW	Pe > 300 mbar Q<1200kW	Pe < 300 mbar Q>1200kW	Pe > 300 mbar Q>1200kW
1- Compensator	1- Compensator	1- Compensator	1- Compensator
2- Ball valve	2- Ball valve	2- Ball valve	2- Ball valve
3- Gas filter	3- Gas filter	3- Gas filter	3- Gas filter
4- Inlet manometer + valve	4- Inlet manometer + valve	4- Inlet manometer + valve	4- Inlet manometer + valve
8 – Multi-block (safety and operation solenoids)	5- Regulator	8 – Multi-block (safety and operation solenoids))	5- Regulator
10- max. gas pressure switch	6- Outlet manometer + valve	9- Sealing Control Set	6- Outlet manometer + valve
11- min. gas pressure switch	7- Safety discharge valve	10- max. gas pressure switch	7- Safety discharge valve
	8 – Multi-block (safety and operation solenoids)	11- min. gas pressure switch	8 – Multi-block (safety and operation solenoids)
	10- max. gas pressure switch		9- Sealing Control Set
	11- min. gas pressure switch		10- max. gas pressure switch
			11- min. gas pressure switch

8. MAINTENANCE

8.1. Monthly Maintenance

Monthly maintenance is a comprehensive process where general checks of burner and peripheral components are performed to prevent possible faults.

- Ø Clean the filters on the main line and multiblock.
- Ø Check the burner gas tip.
- Ø Perform insulation measurements of ignition and ionization electrodes, replace electrodes should there be leakage to the body.
- Ø Check ignition cables and sockets.
- Ø Check all wiring points. Tighten loose connections.
- Ø Clean the dust and layers accumulated on the fan and air klappes.
- Ø Check gas line pressure, it must be the same with the first adjusted pressure, otherwise burner load and emission values will also have changed.
- Ø Check all bolts of the burner. Tighten loose bolts.

8.2. Seasonal Maintenance

Comprehensive maintenance work when the burner is re-started after long periods of shut-down or interruptions. After completion of maintenance and adjustment processes, make sure to perform a combustion analysis.

- Ø Check insulation resistance of electric motor.
- Ø Replace ignition and ionization electrodes with new ones.
- Ø Clean air fan and clamps.
- Ø Check the operating function.
- Ø Check boiler thermostats.



Follow installation directions during maintenance.

9. TROUBLESHOOTING

Problem	Cause	Explanation-Suggestion
Burner cannot be commissioned	Gas is cut or does not come	Gas valve might be closed. Open the valve.
	Fuse failure	Check burner power supply. The fuse on the main panel or the fuse on the burner might be tripped.
	Relay failure	Reset the thermal relay. Check adjustment of the thermal relay according to the current in motor label. If the failure is not removed, replace the thermal relay.
	Boiler thermostat, pressure switch failure	If there is a problem with the burner thermostats, pressure switches and steam tank this may be due to an unadjusted or faulty water level device; adjust it and if broken, replace it.
Flame appears and goes into failure mode.	Gas pressure error	Supply gas pressure might be low.
	Ionization electrode failure	Ionization electrode may be faulty or contaminated. Remove and clean.
	Program relay failure	Replace it with a new one.
Burner starts up, but fails after 10 seconds.	Air pressure switch adjustment	Air pressure switch might be adjusted to a high value. There may be dirt in the air pressure switch. Air pressure switch might be broken.
	Program relay failure	Replace it with a new one.
	Fan motor failure	Check fan motor coils, motor contactor and outlet from program relay.
Burner starts up, but fails after 30 seconds.	Gas valve, gas pressure drop	Gas valve might be closed. Supply gas pressure might be low. Check gas inlet manometer.
	Ignition electrode failure	Ignition electrodes might be misadjusted or ignition cables might have come out of their terminals. Adjust ignition electrodes with a distance of 3-5 mm. between them.
	Gas valve adjustment	Check the starting setting of the gas valve. Burner must be adjusted to sufficient start gas flow for its activation.

11. AFTER-SALES SERVICES

Dear Customer,

We believe that providing a good service is as important as providing a good product. Therefore, we continue offering wide range of comprehensive services to our conscious customers.

Our contact details for your requests and complaints

Esentepe Mah. Milangaz Cad. No:75 K:3

**Kartal Monumento Plaza
KARTAL/İSTANBUL/TÜRKİYE**

Tel: +90 216 442 93 00

Fax: +90 216 370 45 03

Factory Contact Details

Türkgücü OSB

**Bülent Ecevit Bulvarı No:11
ÇORLU/TEKİRDAĞ/TÜRKİYE**

Tel: +90 282 685 44 80-81

Fax: +90 282 685 42 09

Also you can contact with us:

Web site : www.ecostar.com.tr

E - mail : servis@ecostar.com.tr



Please observe the following recommendations.

- Use the product in accordance with the principles of this manual.
- For any service demands regarding the product, please contact our Service Center from the abovementioned phone numbers.
- Upon your purchase, register your warranty certificate during installation.

