

HEAVY OIL PROCESS BURNERS INSTALLATION, OPERATING AND MAINTENANCE MANUAL

ONE STAGE, TWO STAGE AND MODULATING OPERATION

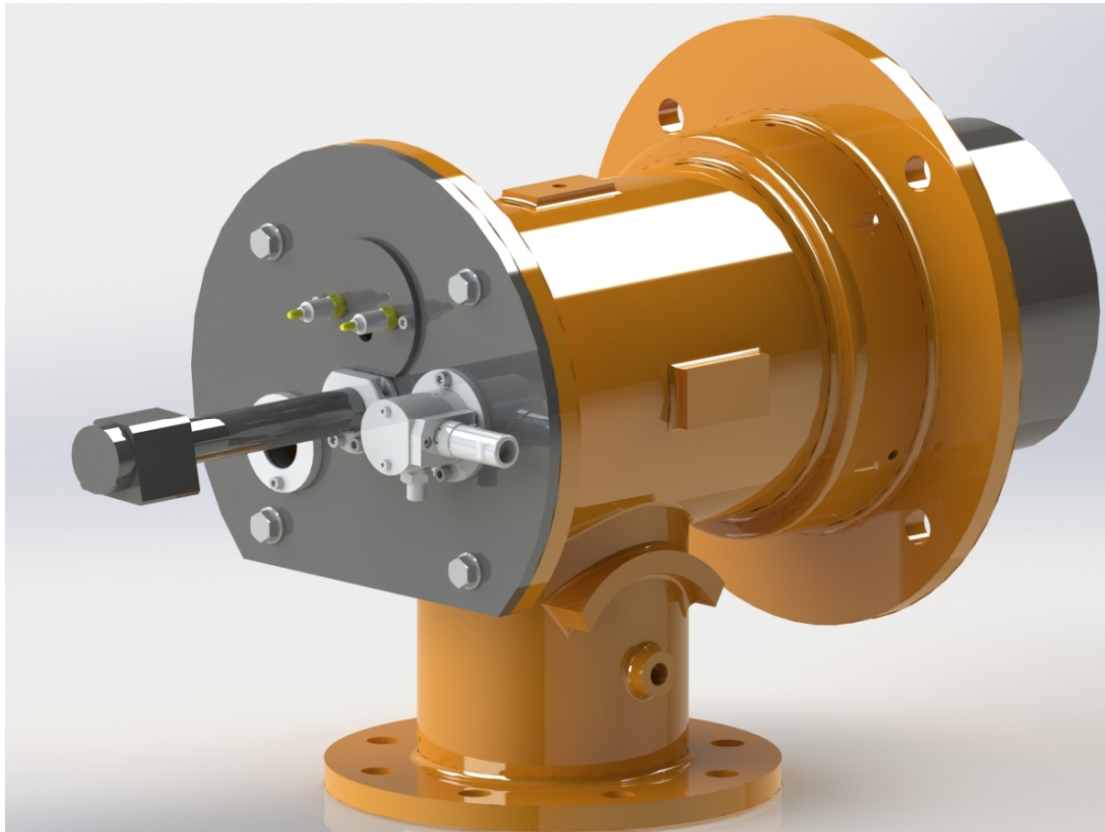

FPB 200
FPB 300
FPB 400
FPB 550
FPB 870
FPB 1200
FPB 1600
FPB 2000
FPB 2500
FPB 3500
FPB 5000

DEAR USER,

ECOSTAR FPB 200, FPB 300, FPB 400, FPB 550, FPB 870, FPB 1200, FPB 1600, FPB 2000, FPB 2500, FPB 3500, FPB 5000 Heavy Oil process burners are prepared and manufactured according to the latest technical developments and safety rules. It is easy to use for our customers.

We recommend that you read this manual and safety warnings thoroughly before the use of the device in order to ensure safe, cost effective and environmental-friendly use.

If you encounter any issue that is not explained clearly in this manual or you could not understand, please contact with our service department.

We thank you for choosing ECOSTAR brand.





This Operating Manual is an integral part of the burner and must be maintained in a plastic dossier and hung at a clearly visible place in the burner room.

CONTENTS

1. WARNINGS.....	3
1.1. Warning Symbols and Descriptions.....	3
1.2. General Safety Rules.....	4
2. TERMS OF WARRANTY.....	6
2.1. Out of Warranty Conditions.....	6
3. BURNER'S GENERAL FEATURES.....	7
3.1. Purpose of Use and Work Limits of Burners.....	7
3.2. Process Burner Components.....	9
4. FLUE GAS AND HEATING WATER SCHEMA.....	10
5. TECHNICAL DATA.....	11
5.1. Capacity Table.....	11
5.2. Burner Dimensions.....	12
6. INSTALLATION.....	13
6.1. Burner Installation Picture.....	13
7. COMMISSIONING.....	14
7.1. Before Commissioning.....	14
7.2. General Controls and Commissioning.....	14
7.3. Fuel Adjustment.....	14
7.4. Combustion Adjustment.....	15
7.5. Oil pump.....	15
7.6. Fuel Diagrams.....	16
7.7. Servomotor Adjustment.....	19
7.8. Program Relay.....	24
7.9. Heavy Oil Burner Fuel Ring Line.....	26
8. MAINTENANCE.....	27
8.1. Weekly Maintenance.....	27
8.2. Monthly Maintenance.....	27
8.3. Seasonal Maintenance.....	28
9. TROUBLESHOOTING.....	29
10. PERIODICAL FLUE GAS MEASUREMENT REPORT.....	30
11. AFTER SALES SERVICES.....	31
12. NOTES.....	32

1. WARNINGS

1.1. Warning Symbols and Descriptions

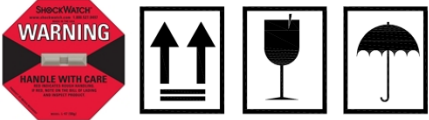
Symbols	Symbol Descriptions
	<p>Important information and useful hints.</p>
	<p>Warning of danger to life or property.</p>
	<p>Warning of electrical voltage.</p>
	<p>Product handling information.</p>
	<p>Carry in an upright position. Fragile Item. Protect against water.</p>

1.2. General Safety Rules

- All personnel engaged in installation, disassembly, commissioning, operation, control, maintenance and repair should have received the necessary training and fully read and understood this manual.
- No changes that might damage the safety of the burner unit must be made by persons and/or organizations on the burner unit.
- All operation, commissioning and installation works (except for burning adjustment) should be carried out when the burner is not operating and after disconnecting the power supply. Noncompliance with these rules may lead to serious bodily injuries and even death by electrical shocks or uncontrolled flame formation.
- Repairs concerned with safety elements should be carried out only by the manufacturing company.
- The device should never be used by children, mentally handicapped and inexperienced persons.
- Children must not be allowed to play with the device.
- Keep the device away from explosive and flammable materials.
- Device must intake air, ventilation and air discharge holes must not be closed.



Do not store any inflammable materials in boiler room.



Wear hearing protectors if there is noise in boiler room.



In case of fire or other emergency;

- Switch off the main switch
- Take appropriate actions



Install burner firmly. Vibration may damage burner or its components.



Keep boiler doors closed while starting burner and during burner operation.



During the first commissioning of the burner or in case of any revision carried out in the electrical system or motor cables by any reason, direction of the fan rotation must certainly be checked by the authorized technical service.



For products that have not been commissioned or started more than 6 months, before activating the servomotor;

In air dampers and oil regulators, servomotor and air damper connections must be checked to ensure that they are free running in spite of immobility and oil freezing.



In products used in high temperature oven applications; When the burners are not operated / are switched off, The air flaps must be set to remain in the half-open position, to prevent the burner components being damaged by hot air.



BURNER ROOM

Install the burner in a suitable room/floor with minimum external air openings and sufficient to ensure perfect combustion, in compliance with current regulations.

Never obstruct air openings of the burner room, burner fan intake vents or air ducts in order to prevent:

a. The build up of toxic / explosive gas mixtures in the burner room,

b. Combustion with insufficient air, resulting in hazardous, anti-economical and polluting operation.

The burner must be always protected from rain, snow and frost to prevent corrosion and paint deformations.

Keep the burner room clean and free of solid volatile substances, which could be sucked into the fan and clog the internal burner or combustion head air ducts.

2. TERMS OF WARRANTY

Main and auxiliary equipment and all components used in Ecostar heavy-oil process burners are guaranteed for 1 year by TERMO ISI SİST. A.Ş starting from the date of commissioning under the maintenance, adjustment, operating conditions and relevant mechanic, chemical and thermal effects explained herein.



Please note that this warranty is only valid if the device(s) is commissioned and maintained by our authorized services.



Our company reserves the right to make any modifications on the product and all instructions thereof for improvement purposes.

2.1. Out of Warranty Conditions

- Any damage arising out of or in relation to customers' non-compliance to their responsibilities with regards to installation, commissioning, operation and maintenance,
- Any damage arising out of or in relation to commissioning, repairs and maintenance carried out by unauthorized services,
- Any damage that may occur during transportation or storage of the product,
- Not preserving the product in its original packaging until the installation stage,
- Incorrect and poor electrical connections, Failures due to incorrect voltage applications, frequent repetition of voltage fluctuations,
- Any damage that may occur as a result of incorrect fuel usage or, foreign substances in the fuel used or using of the product without any fuel,
- Any damage that may occur due to foreign particles entered into the product during installation and operation,
- Failures due to incorrect device selection,
- Any damage to unit due to natural disasters,
- Devices without any warranty certificates,
- Warranty Certificates without the stamp and signature of the authorized dealer or service,
- Devices with any falsification on the warranty certificate or without an original serial number.
- The risks during transportation of device under the responsibility of customer belong to the customer.
- Presence of misuse faults are indicated in the reports issued by authorized service stations or our authorized agent, dealer, representative or our factory in case of unavailability of authorized service stations.
- Customers may apply consumer protection arbitrator committee with regards to this report and request for an expert report.

3. BURNER'S GENERAL FEATURES

ECOSTAR Heavy Oil burners are designed to operate with oil at 2.5 – 20 Cst (mm²/s) viscosity, at rated capacity and pressure ranges and -15% to +10% nominal voltage.

3.1. Purpose of Use and Work Limits of Burners

- This product works at any load value equivalent to its max. capacity or covered by its capacity range;
 - -15 °C...+60 °C ambient temperature range,
 - 1N 230 VAC/3N 380VAC /50 Hz feed voltage (-%15...+%10) values,
 - Max. 95% relative humidity,
 - In well-ventilated open and closed spaces compatible with protection class IP 40.



This device must never be operated with open flame!

c St

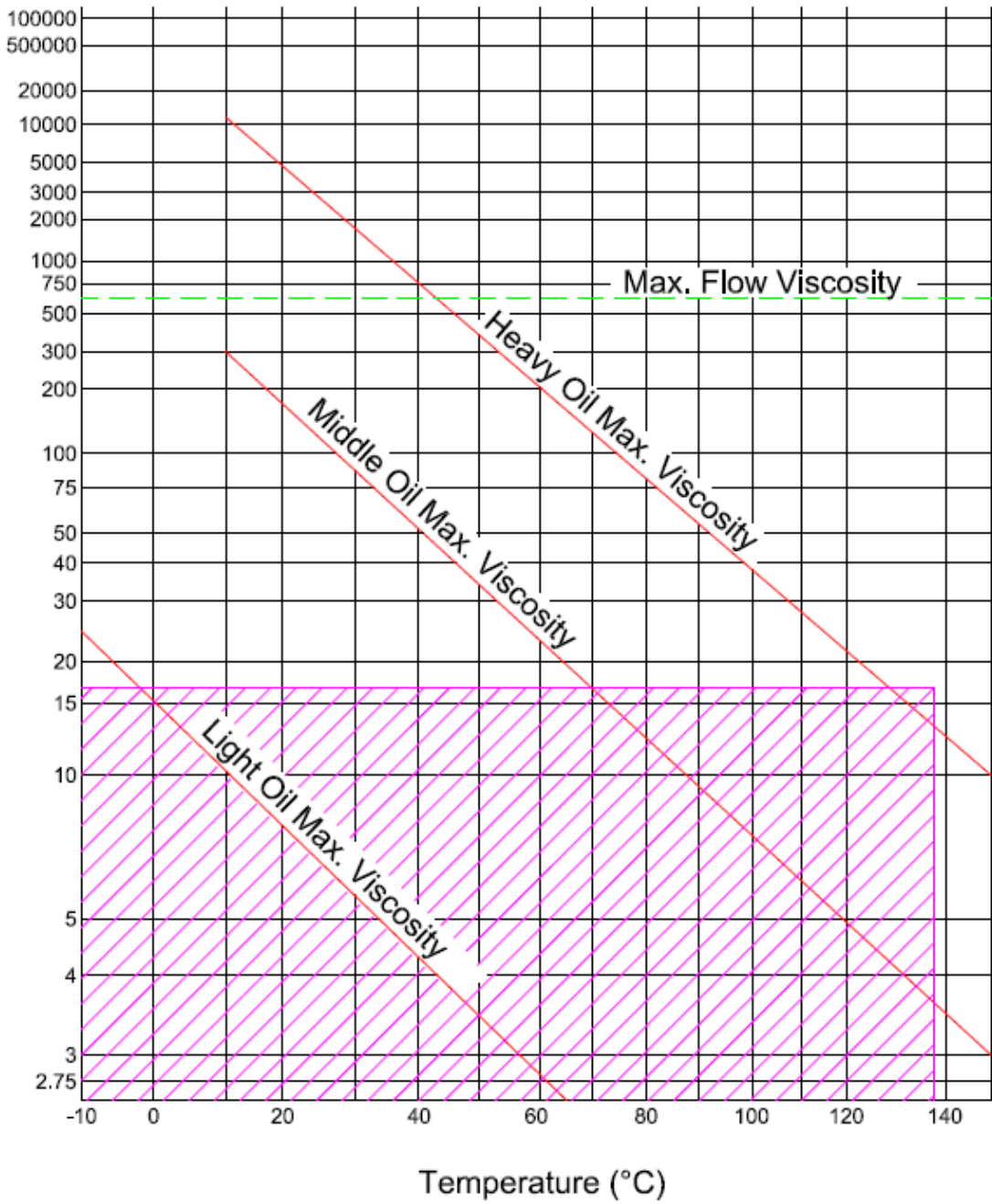

Temperature change of fuel used in ECOSTAR Heavy Oil process burners dependent on viscosity



Operating Range

3.2. Process Burner Components

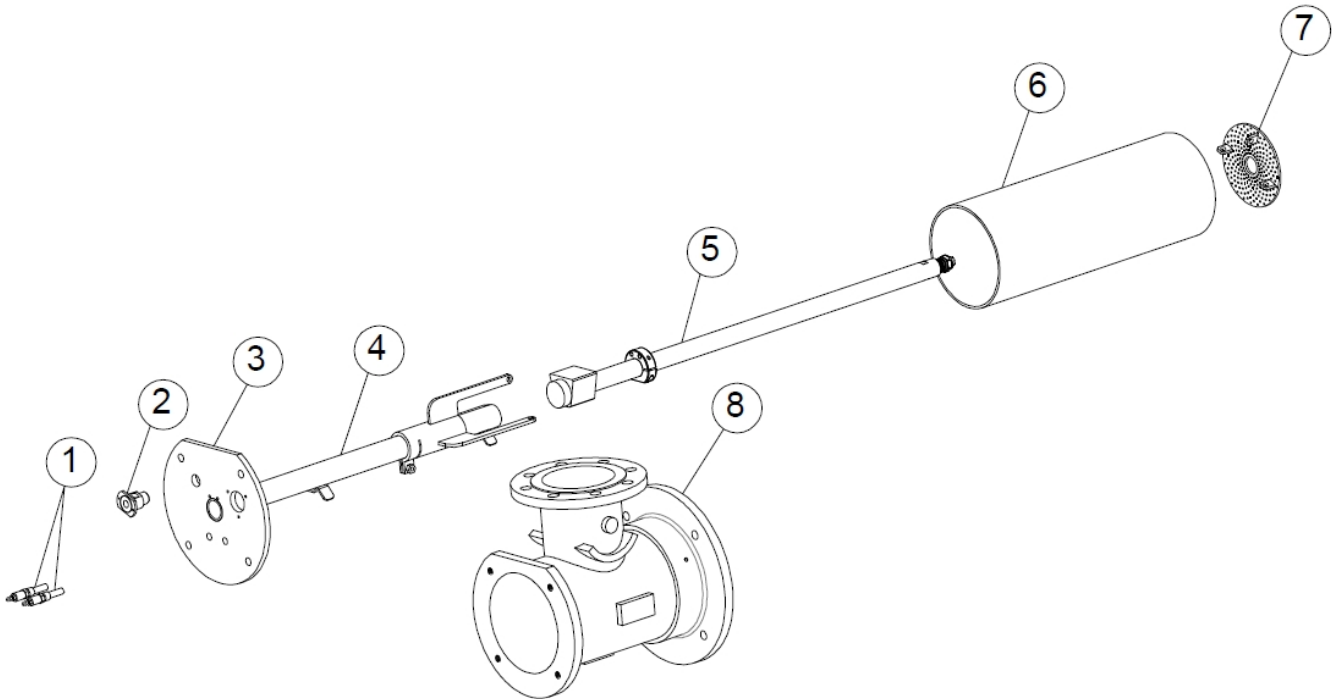

- 1- Ignition Electrodes
- 2- Photocell
- 3- Casing Flange
- 4- Diffuser and Nozzle Centering Pipe
- 5- Nozzle
- 6- Flame Tube
- 7- Diffuser
- 8- Body

4. FLUE GAS AND HEATING WATER SCHEMA

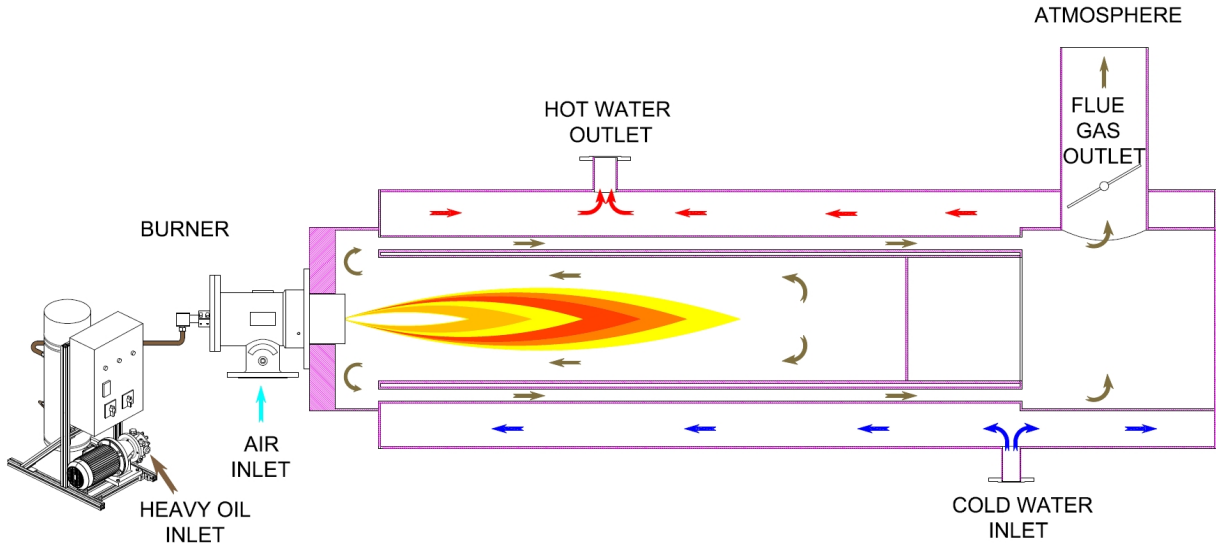

5. TECHNICAL DATA

5.1. Capacity Table

FPB PROCESS BURNER							
	CAPACITY		CAPACITY		HEAVY OIL CONSUMPTION		FAN FLOW RATE
	Min.	Max.	Min.	Max.	Min.	Max.	
	Kcal/h		kW		kg/h		Nm ³ /h
FPB 200	40.000	200.000	46,5	232,6	4,1	20,7	350
FPB 300	60.000	300.000	69,8	348,8	6,2	31,1	500
FPB 400	80.000	400.000	93,0	465,1	8,3	41,5	650
FPB 550	110.000	550.000	127,9	639,5	11,4	57,0	900
FPB 870	174.000	870.000	202,3	1011,6	18,0	90,2	1.400
FPB 1200	240.000	1.200.000	279,1	1395,3	24,9	124,4	2.000
FPB 1600	320.000	1.600.000	372,1	1860,5	33,2	165,8	2.500
FPB 2000	400.000	2.000.000	465,1	2325,6	41,5	207,3	3.100
FPB 2500	500.000	2.500.000	581,4	2907,0	51,8	259,1	4.000
FPB 3500	700.000	3.500.000	814,0	4069,8	72,5	362,7	5.500
FPB 5000	1.000.000	5.000.000	1162,8	5814,0	103,6	518,1	7.800

H_u Heavy Oil (S) = 9650 Kcal/kg

5.2. Burner Dimensions

FPB 200

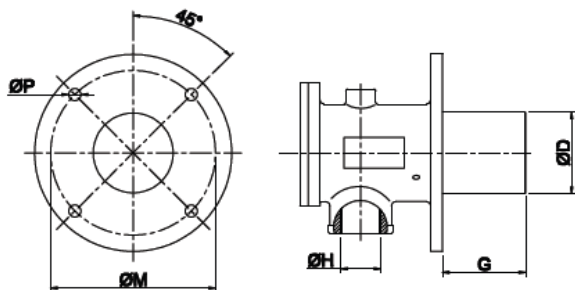

FPB 300 - 400 - 550 - 870 - 1200

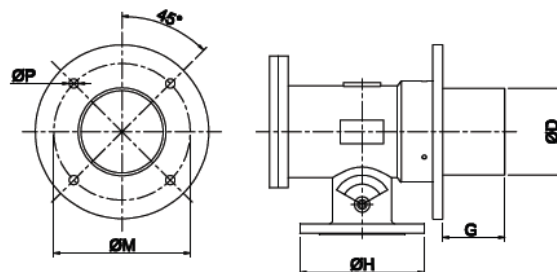

FPB 1600 - 2000 - 2500 - 3500 - 5000

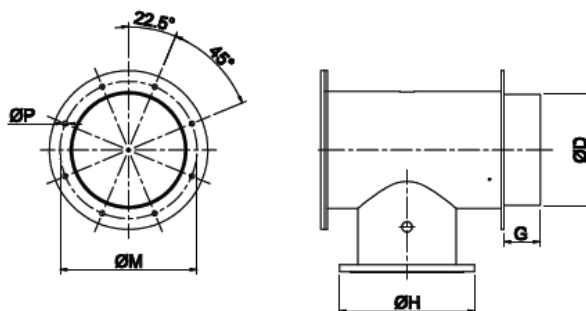

FPB BURNER		ØD	ØH	ØM	ØP
		mm	-	mm	mm
CAST BODY	FPB 200	100	R 2"	198	12
	FPB 300	140	NW 80	220	15
	FPB 400	140	NW 80	220	15
	FPB 550	175	NW 100	243	15
	FPB 870	220	NW 150	330	17
	FPB 1200	220	NW 150	330	17
STEEL BODY	FPB 1600	308	NW 250	380	14
	FPB 2000	308	NW 250	380	14
	FPB 2500	240	NW 250	380	14
	FPB 3500	322	NW 350	480	17
	FPB 5000	322	NW 350	480	17

6. INSTALLATION

6.1. Burner Installation Picture

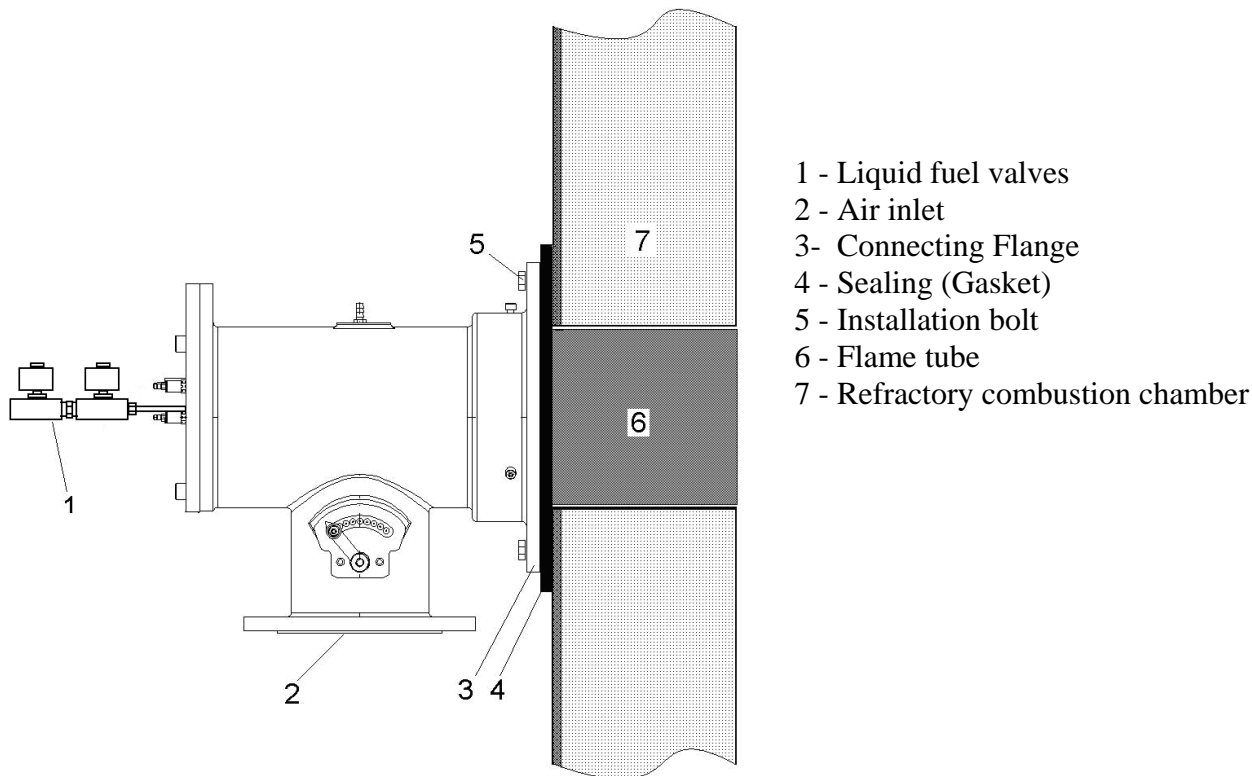

After completing the installation of the burner on the boiler:

- Ø Connect the oil feed pipes.
- Ø Connect the burner panel to the mains by a cable suitable for the rated power.



Clean the inside of fuel line thoroughly before installing the burner to the fuel line. Any damage that may occur due to solid objects and metal particles from the fuel line shall not be covered by our company.

7. COMMISSIONING

7.1. Before Commissioning



Make sure to perform the following controls before commissioning the burner.

- Has heat demand been formed?
- Are the thermostat and other thermo-elements for control purposes working properly?
- Are the electrical connections correct?
- Is there electricity current?
- Is there sufficient air flow? (**capacity kW x 7 = ventilation section area cm²**)
- Has the boiler been installed correctly?
- Has the sealing of fuel lines been controlled?
- Check the temperature of the heavy-oil coming from the daily storage tank to the burner (should be 50°C ±5).
- Check the fuel line (are the pipe diameters and the pipe installation correct?).
- Check the fuel nozzles according to the capacity.

7.2. General Controls and Commissioning

- Open the fuel tank valve.
- Open the valve upstream of the fuel filter.
- Open the pump's vent plug and place the manometer (0-40 bar).
- Switch on the burner's switch.
- When the burner starts up, the motor is activated and turns the pump at the same time.
- After the pre-purge, fuel is delivered from the nozzle. The fuel meets with the flame from the ignition electrodes and the combustion starts.
- Pump pressure is adjusted after the burner is burnt.
- If the burner has two stages, the switch is brought to position "2", and the capacity of the burner is increased through servomotor.
- Thermostat is adjusted upon request.
- For the safety of the system, check the thermostats and observe the deactivation of the burner.

7.3. Fuel Adjustment

One-stage burners

- Pump pressure (18 bar for heavy – oil) is adjusted and hourly fuel consumption is realized according to the selected fuel nozzle.

Two-stage burners

- Pump pressure (18 bar for heavy – oil) is adjusted and hourly fuel consumption is realized according to the selected fuel nozzle.

Modulating burners

- Fuel regulator, disk mechanism and servomotor adjustments are made and the minimum and maximum capacity values are set, so that the rotation pressure is 10 bar and maximum return pressure is 20 bar at the inlet pressure of 25 bar.

7.4. Combustion Adjustment

Ø Fuel nozzle

Use proper wrench in installation and dismantle of the fuel nozzle.

Use diesel oil to clean the fuel nozzle. Do not use thinner and its derivatives.

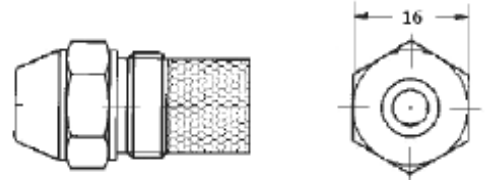

Ø Photocell

Check the photocell weekly. Clean the dust or fume stains on the glass of photocell by a dry cloth.

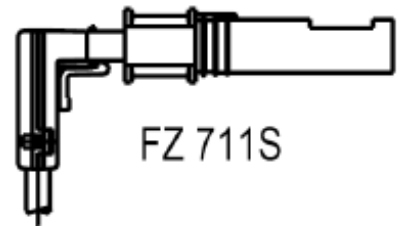

7.5. Oil pump

1. Oil inlet connection
2. Pressure adjustment screw
3. Oil return connection
4. Manometer connection
5. Pressurized oil outlet connection

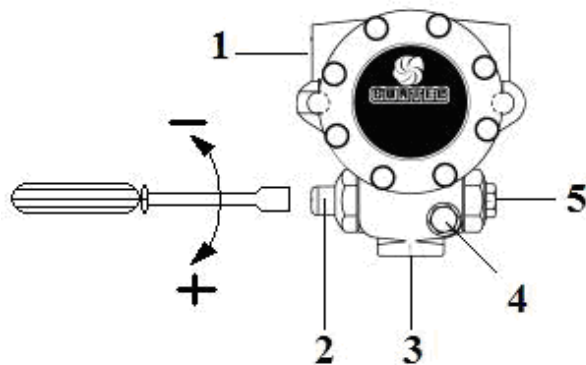

7.6. Fuel Diagrams

Ø One Stage Heavy Oil Burner Fuel Circuit

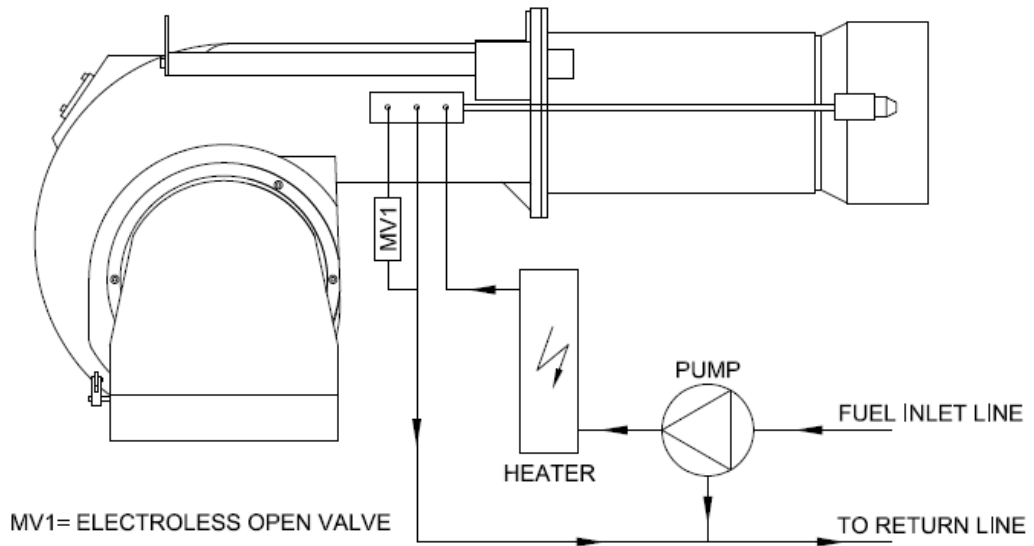

Ø Two Stages Heavy Oil Burner Fuel Circuit

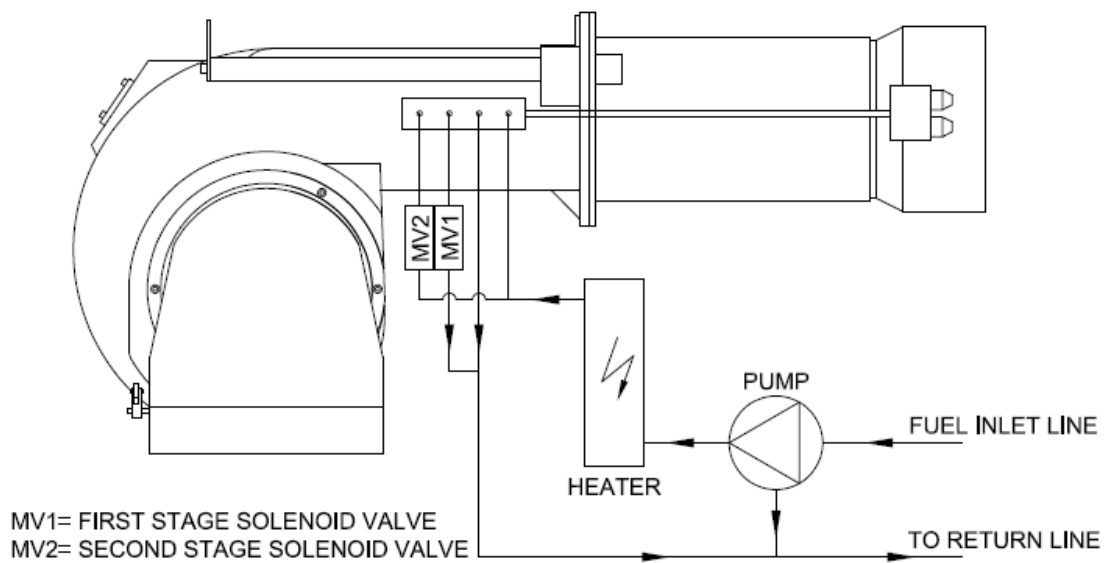

Ø Modulating Heavy Oil Burner Fuel Circuit

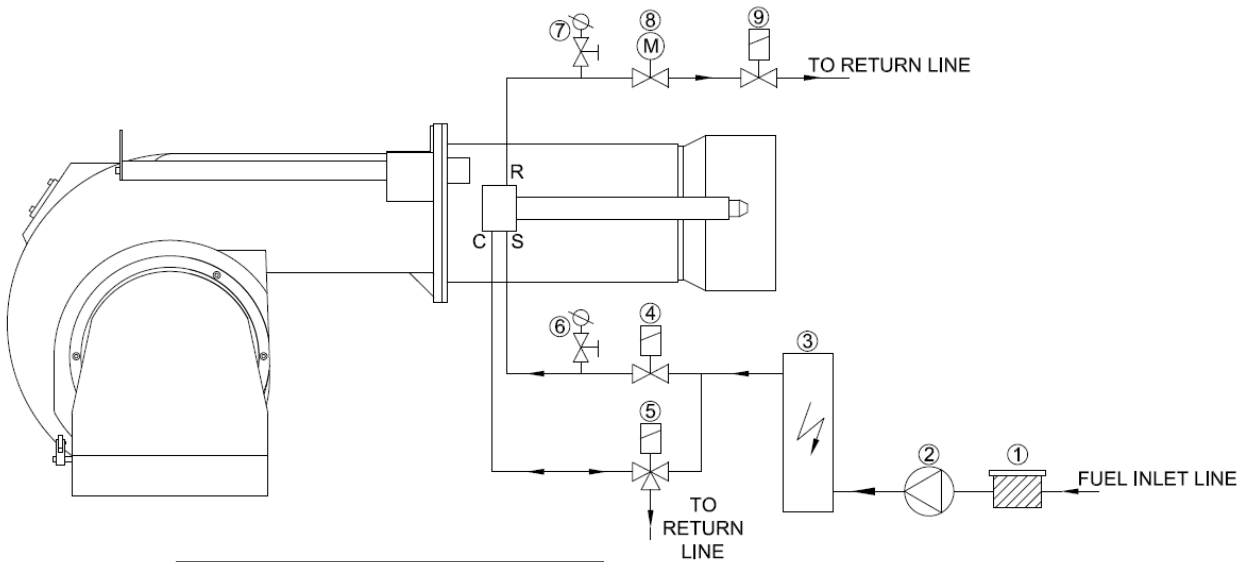

1	FILTER
2	PUMP
3	HEATER
4	FUEL INLET VALVE
5	HYDRAULIC CONTROL VALVE
6	MANOMETER
7	MANOMETER
8	OIL REGULATING VALVE
9	FUEL RETURN VALVE



CAUTION!

- Ø End of the line to the main tank must be open to the atmosphere and line pressure must be zero, otherwise no healthy modulating operation can be ensured since the pressure, which is to form in return, will also affect nozzle pressure. Fuel may drop from nozzle end during stops.**
- Ø For good pulverization, periodically check durability of the o-ring. In the event of earing of the o-ring, fuel to the nozzle can by-pass and go directly to the return and reduces the working performance of the nozzle.**
- Ø Maximum operating pressure of the nozzle is 30 bars, while its maximum operating temperature is 140°C. These values should not be exceeded during working. Even if these out of control value are exceeded, nozzle must be taken to emergency maintenance and all O-rings must be replaced.**
- Ø Do not use solvent based materials (thinner and derivatives) during cleaning of the fuel nozzle; clean with gas oil or diesel oil. Fuel nozzle inner kit is very sensitive and even invisible deformations can reduce working performance; dismantling-installing work must be performed only by trained personnel.**
- Ø Spring has lost its function if dropping from fuel nozzle or fuel exit at large scale is observed when the nozzle performs circulation. It must be checked and replaced if necessary.**

Ø Burner preheater

1. Fuel inlet
2. Fuel outlet
3. Discharge
4. Fixing plate
5. Resistance
6. Thermostat bulb pipe
7. Housing cover

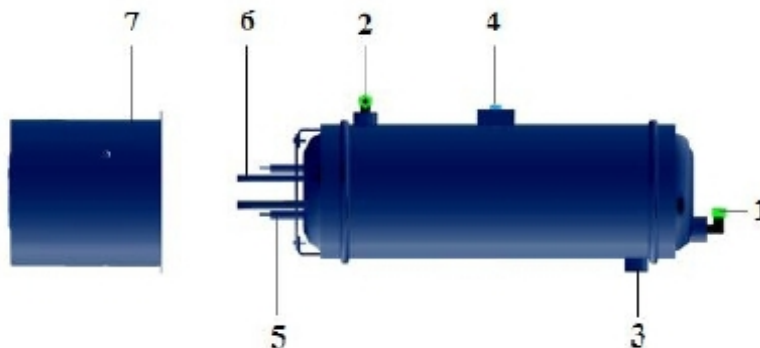

7.7. Servomotor Adjustment

Ø SQN70

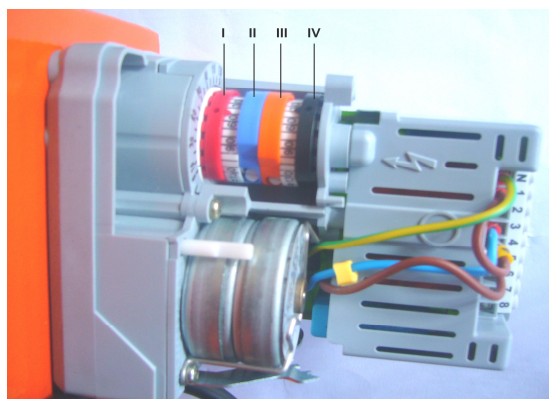

At Two-stage Burners;

- I. Red Cam: Adjusts 2nd level max. air.
- II. Blue Cam: Resets the clamp.
- III. Orange Cam: Adjusts 1st level min. air.
- IV. Black Cam: Adjusts 2nd level valve opening degree.

At Modulating Burners;

- I. Red Cam: Performance max. air adjustment.
- II. Blue Cam: Resets the clamp.
- III. Orange Cam: Performs min. air adjustment.
- IV. Black Cam: Not used.

Ø SQM10



- I. Cam: Opening
- II. Cam: Resets the clamp
- III. Cam: Commissioning air
- IV. V.VI. and VII. Cam not used

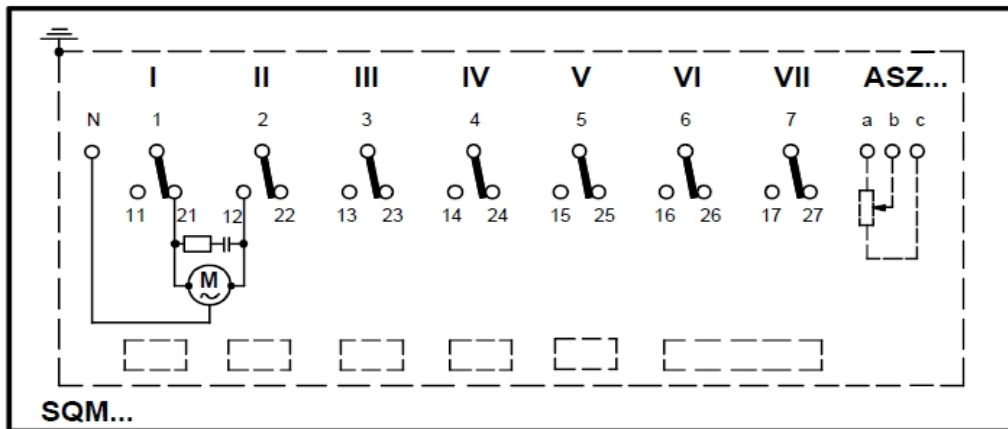

7812a01/1097

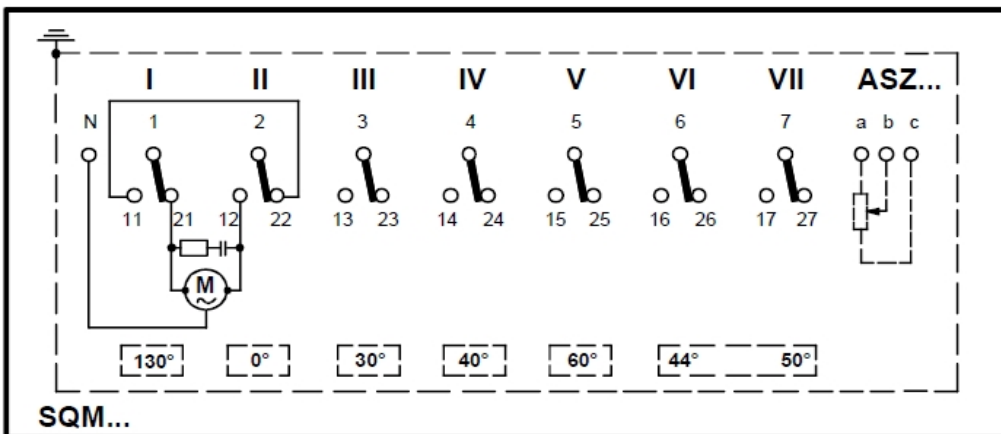

7812a02/1097



Do not open servomotor. Do not interfere with. It may damage servomotor or change burner settings.



Burner's actuators should not be installed closer to high temperature zones, max allowed ambient temperature should be 60 °C for actuator's operation safety

Ø MODULATING MECHANISM ADJUSTMENT

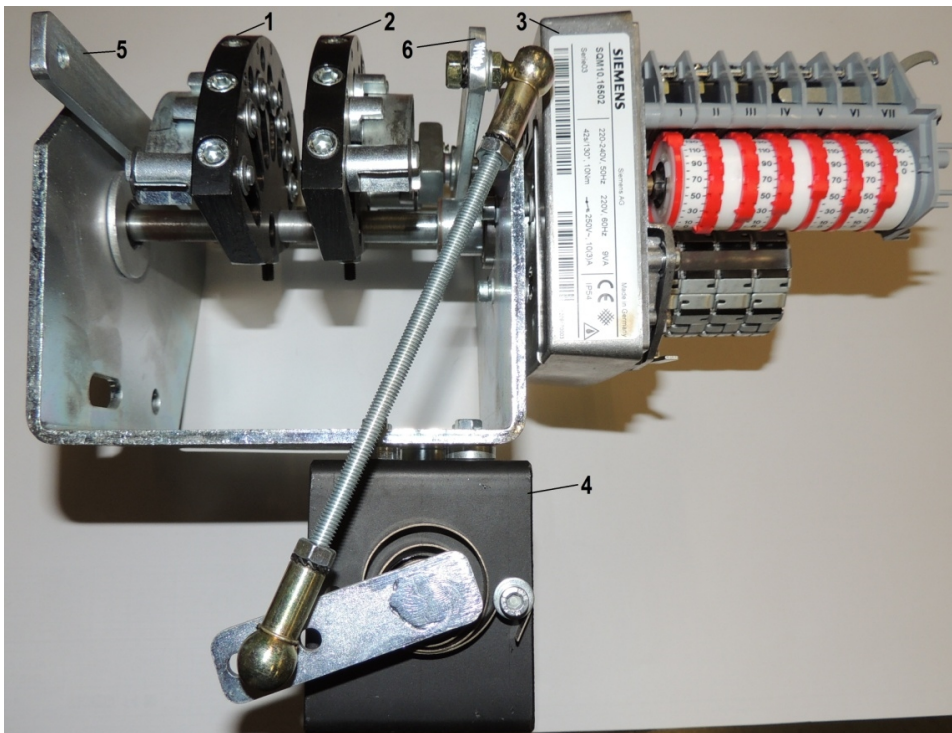

- 1- Air adjustment disk
- 2- Fuel adjustment disk
- 3- Servomotor
- 4- Fuel regulator
- 5- Air control lever
- 6- Fuel control lever

ADJUSTMENT:

1- Start positions prior to disc mechanism adjustment operation must be as follows:

- Ø Servomotor: 0°
- Ø Fuel adjustment disc at start position
- Ø Air adjustment disc at start position
- Ø Fuel regulator at position 10
- Ø Air klappes at fully closed position: 0°

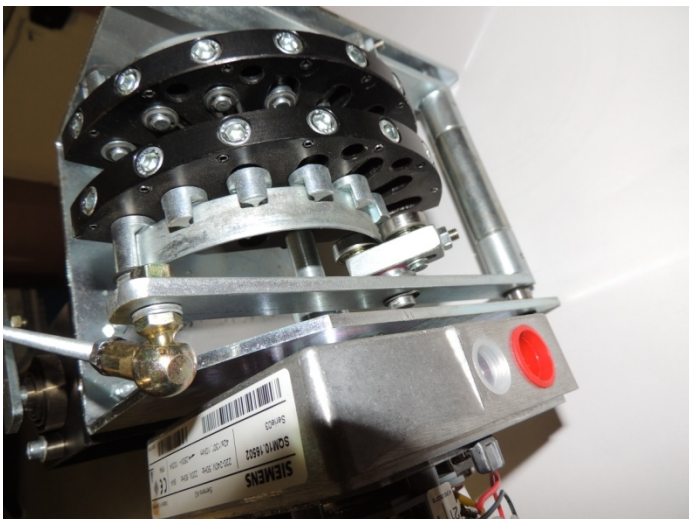

Start position for discs



Start position for fuel regulator

2 – If disc mechanism start positions are correct, start the burner and ensure that it activates in basic load. Detect min capacity activation fuel amount of the burner by checking min. return pressure. If the activation fuel amount is insufficient, set fuel regulator start adjustment to 9 or 8 value by changing spring adjustment from adjusting bolt on fuel disc number 2. When you start the burner again after this operation, you will see that your fuel return pressure has increased and hence activation fuel amount has risen.

3 – Slowly increase the capacity following burner basic load adjustment provided that modulating control device is in manual position. By setting 7 or 8 points during capacity increase, at these points:

- Ø Measure emission values
- Ø Record fuel return pressure
- Ø Observe air klappe position
- Ø Check fuel regulator scale value moves from 10 to 0.

4 – If you haven't been able to reach the max capacity required by the boiler in 90° position of the air klappe and 0° position of the fuel regulator once you have completed the maximum adjustment, follow the below fuel regulator adjustment procedure:

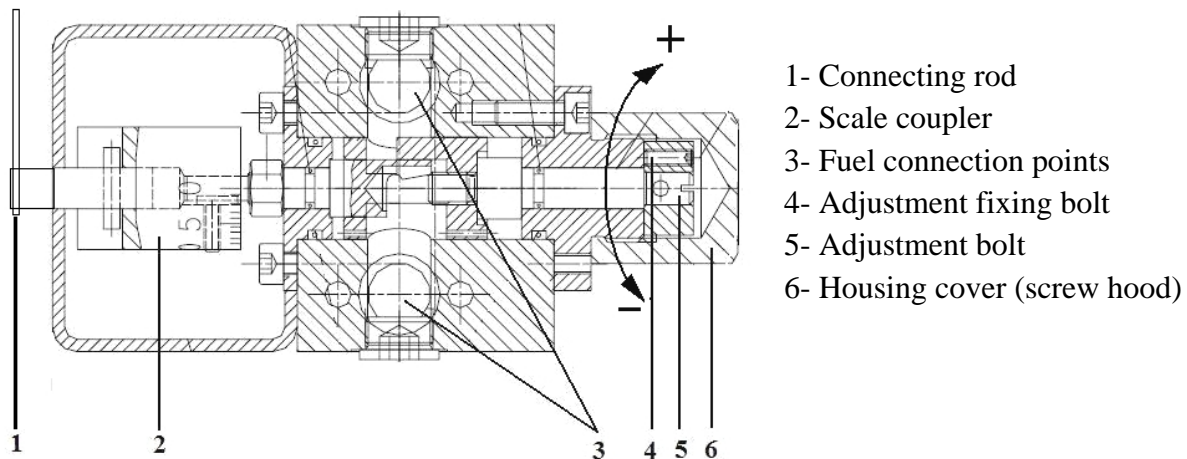

Fuel Regulator Adjustment

- 1- Remove the housing cover number 6
- 2- Loosen the fixing bolt number 4
- 3- When you rotate the shaft number 5 (when looked from the shaft end) clockwise, the pressure value you observe from return manometer will increase, and burner consumption will also increase since nozzle pressure increases.
- 4- When you rotate the shaft number 5 (when looked from the shaft end) anti-clockwise, the pressure value you observe from return manometer will decrease, and burner consumption will also decrease since nozzle pressure decreases.
- 5- When the adjustment is completed, make sure that the adjustment you have made is permanent by tightening the fixing bolt number 4.
- 6- Place the housing cover number 6.

5 - Set the burner to the correct capacity required by the boiler by considering the below nozzle pressure and consumption values.

Diagram valid for fuel nozzles having 45° spraying angle

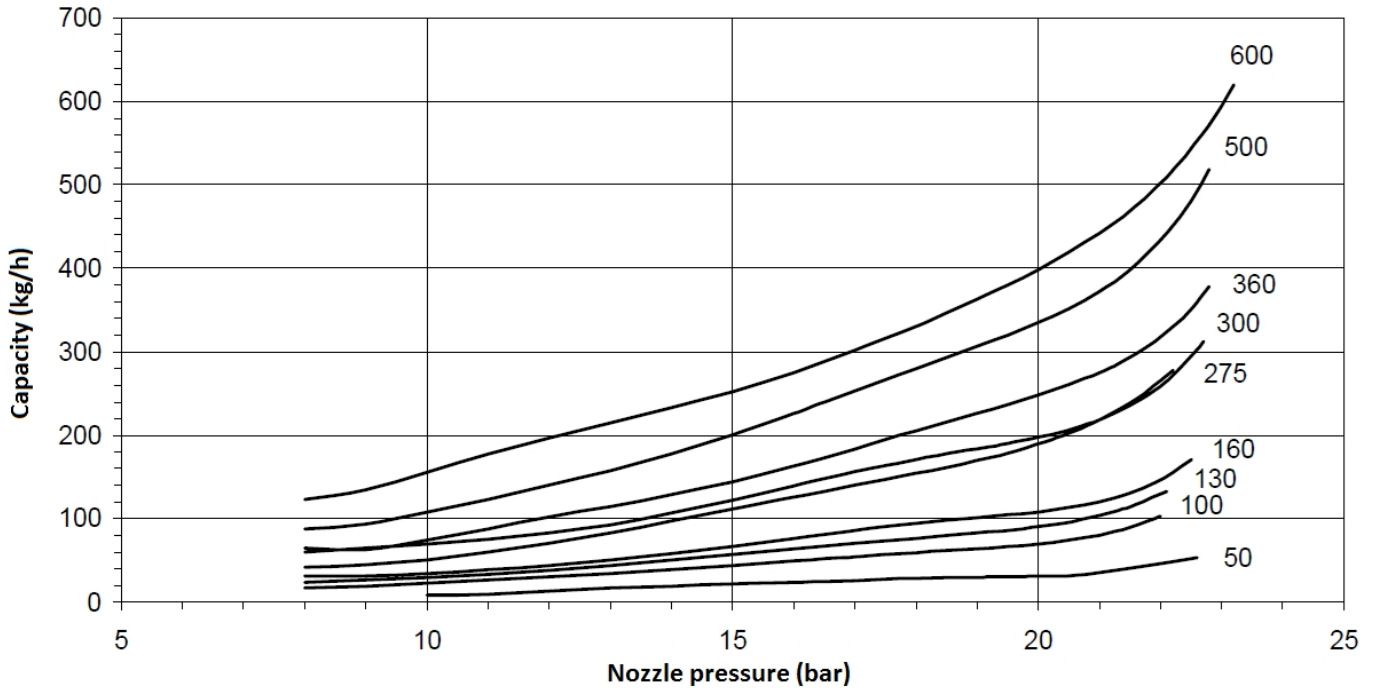
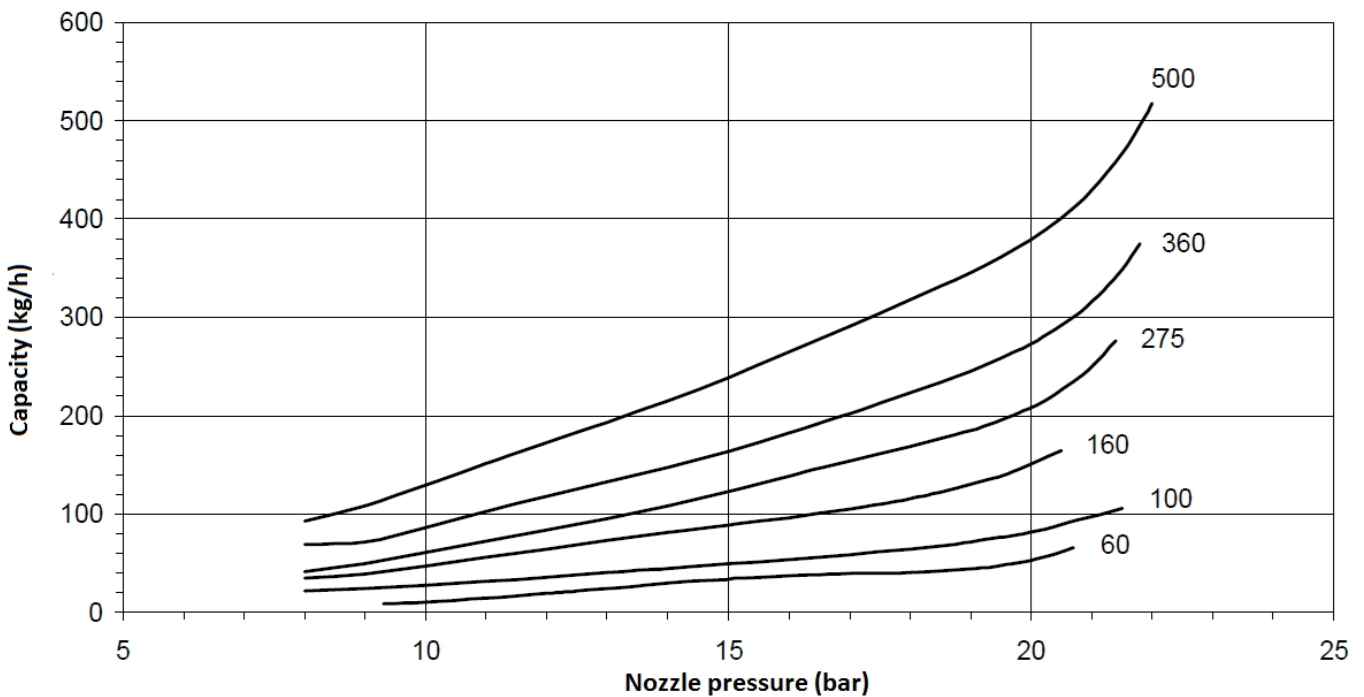

Diagram valid for fuel nozzles having 60° spraying angle



6 – Once the burner modulating adjustment is completed, set modulating control device to automatic position, change set values and observe capacity changes. Air and fuel will increase and decrease simultaneously according to the adjustment you previously made.

7.8. Program Relay

Ø LAL 1.25

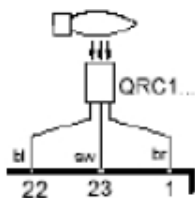
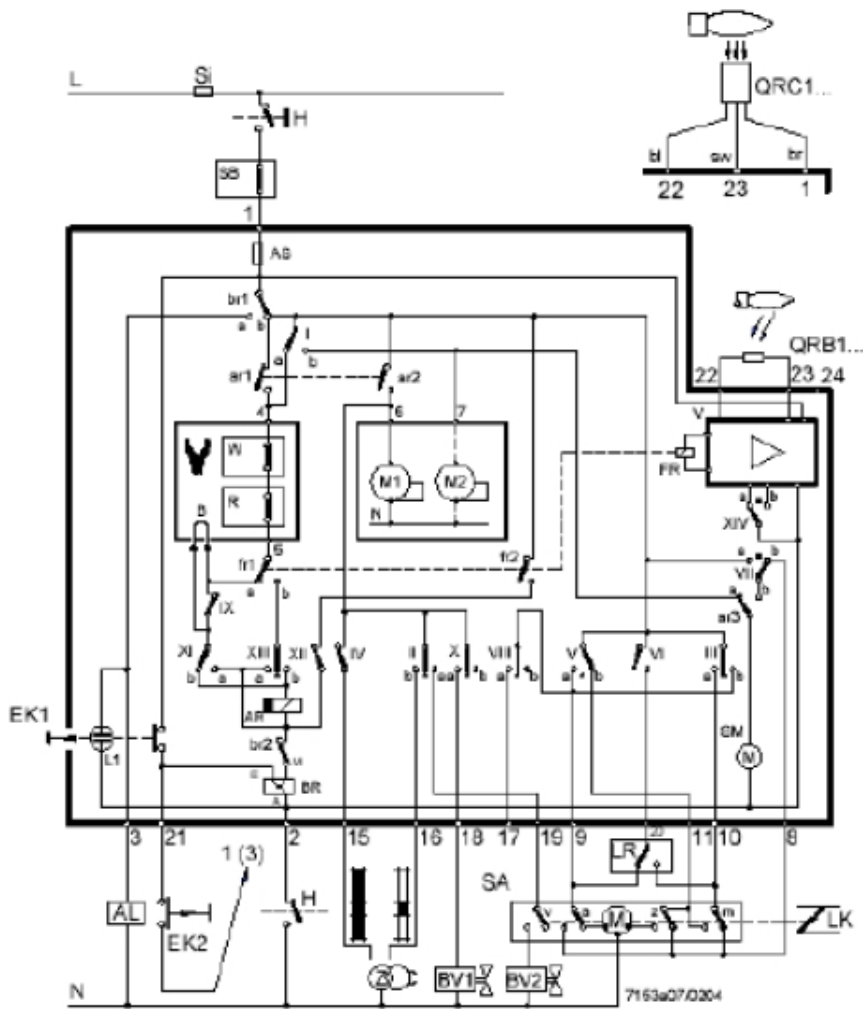

LOA 24

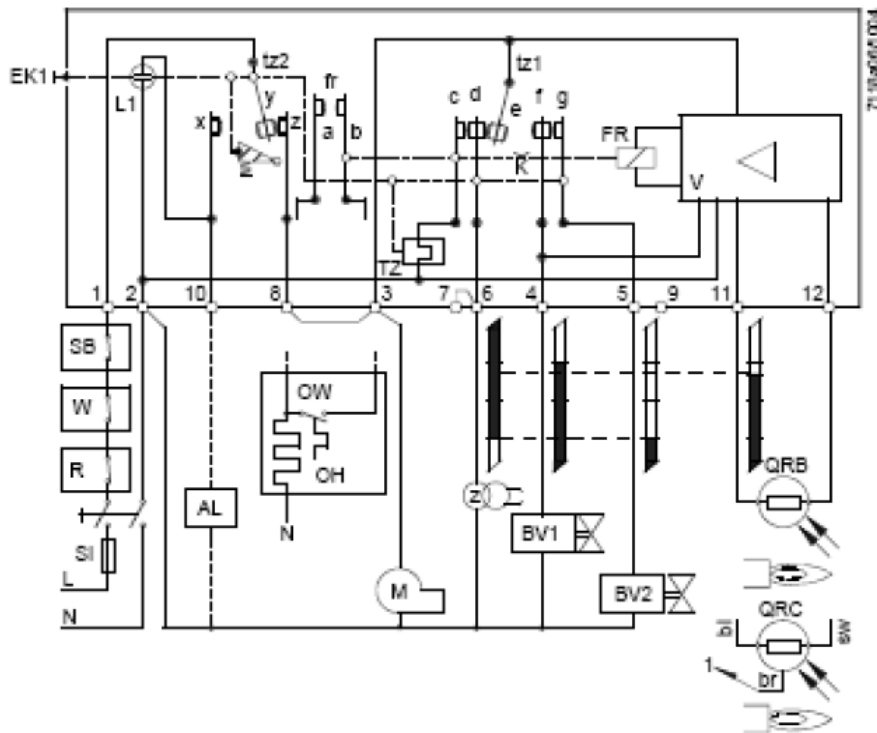

- Ø Red led on: Indicates burner malfunction.
- Ø If the burner switches to the fault mode, please wait at least 30 seconds and reset the program relay.
- Ø Press and hold the light button for 2 sec. to reset the program relay.

7.9. Heavy Oil Burner Fuel Ring Line

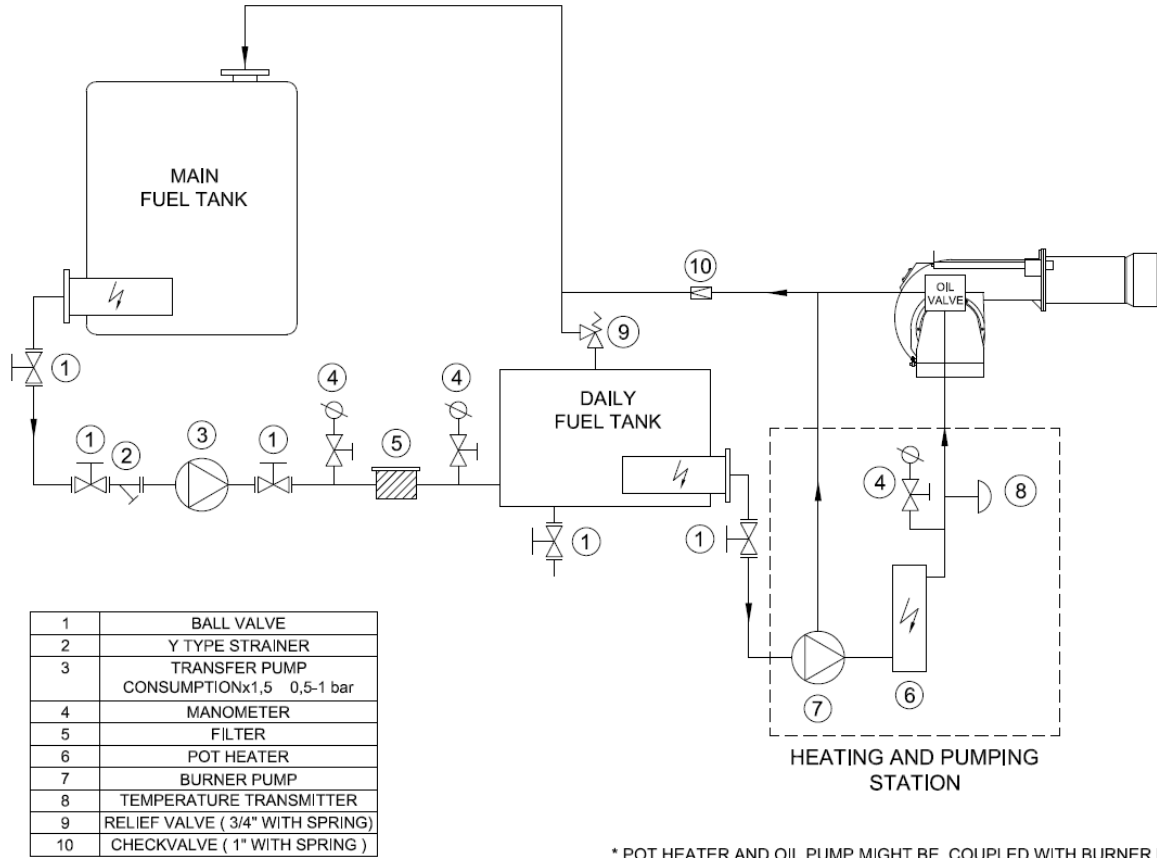

* POT HEATER AND OIL PUMP MIGHT BE COUPLED WITH BURNER BODY OR COME AS A SEPARATE FILTERING-PUMPING-HEATING GROUP ACCORDING TO BURNER CAPACITY.

8. MAINTENANCE

8.1. Weekly Maintenance

Weekly maintenance is a routine cleaning and adjustment procedure which is performed to ensure smooth and continuous operation of the system. Burner components must be adjusted after each maintenance work in accordance with the instructions. Otherwise, the burner cannot be operated efficiently.

- Ø Clean all filters in fuel ring system.
- Ø Clean fuel nozzle of the burner.
- Ø If the fin spaces and surface of the diffuser are covered with particles and formed a layer, clean it with a wire brush.
- Ø Clean heads of ignition electrodes. Check by performing manual ignition, adjust the distance between the ignition electrode and diffuser according to the adjustment instructions.

8.2. Monthly Maintenance

Monthly maintenance is a more comprehensive maintenance compared to weekly maintenance, where general checks of burner and peripheral components are performed to prevent possible faults. After completion of maintenance and adjustment processes, make sure to perform a combustion analysis.

- Ø Clean the filters on the fuel line to the burner.
- Ø Clean fuel nozzle of the burner.
- Ø Clean the surface of the diffuser.
- Ø Clean flame pipe.
- Ø Check all wiring points. Tighten loose connections.
- Ø Clean the solenoid valves.
- Ø Clean the photocell.
- Ø Clean the dust and layers accumulated on the fan and air valves.
- Ø Check pump pressure. Check if necessary (Heavy-Oil: 18bar)
- Ø Check ignition electrodes. Adjust it if necessary. Check ignition cables and sockets.
- Ø Perform cleanliness control of inside panel. Clean if necessary.
- Ø Check all bolts of the burner. Tighten loose bolts.

8.3. Seasonal Maintenance

Comprehensive maintenance work when the burner is re-started after long periods of shut-down or interruptions. After completion of maintenance and adjustment processes, make sure to perform a combustion analysis.

- Ø Check insulation resistance of electric motor.
- Ø Make surface cleaning of ignition electrodes and porcelains. Replace cracked or broken porcelains.
- Ø Clean air fan and clamps.
- Ø Check the operating function.
- Ø Check cleanliness of the nozzle. Replace it if necessary.
- Ø Clean the N.C. solenoid valve. Measure the coil winding resistance.
- Ø Clean the strainer (filter) under the pump cover.
- Ø Clean the photocell.
- Ø Clean fuel filter. Replace it if necessary.
- Ø Check boiler thermostats.

9. TROUBLESHOOTING

Burner does not start.	The mains voltage may not be suitable.	Check mains voltage.
	No power to the burner.	Check burner power supply. The fuse on the main panel or the fuse on the burner might be tripped.
	Thermostat failure	Check thermostat adjustments.
	Air pressure switch failure	Replace the air pressure switch.
Flame occurs, but no combustion.	Fuel valve might be closed.	Supply fuel pressure might be low.
	Photocell failure	Photocell may be faulty or contaminated. Remove and clean it.
	Fuel nozzle or fuel filter might be clogged.	Remove the fuel filter or fuel nozzle.
Burner starts, but fails after 10 seconds.	Program relay failure	Replace it with a new one.
Burner starts, but fails after 30 seconds.	Low fuel pressure	Fuel valve might be closed. Fuel pressure might be low.
	Ignition electrode failure	Ignition electrodes might be misadjusted or ignition cables might have come out of their terminals. Adjust ignition electrodes with a distance of 3-5 mm. between them.

11. AFTER SALES SERVICES

Dear Customer,

We believe that providing a good service is as important as providing a good product. Therefore, we continue offering wide range of comprehensive services to our conscious customers.

Our contact details for your requests and complaints

Esentepe Mah.Milangaz Cad. No:75 K:3

Kartal Monumento Plaza

KARTAL/İSTANBUL/TÜRKİYE

Tel: +90 216 442 93 00

Fax: +90 216 370 45 03

Factory Contact Details

Türkgücü OSB

Bülent Ecevit Bulvarı No:11

ÇORLU/TEKİRDAĞ/TÜRKİYE

Tel: +90 282 685 44 80-81

Fax: +90 282 685 42 09

Also you can contact with us:

Web site : www.ecostar.com.tr

E - mail : servis@ecostar.com.tr



Please observe the following recommendations.

- Use the product in accordance with the principles of this manual.
- For any service demands regarding the product, please contact our Service Center from the abovementioned phone numbers.
- Upon your purchase, register your warranty certificate during installation.

