

# SQUARE BODY MONOBLOCK LIGHT OIL BURNERS INSTALLATION, OPERATING AND MAINTENANCE MANUAL

ONE STAGE AND TWO-STAGE OPERATION



ECO 1.0  
ECO 2.0  
ECO 30.0



**DEAR USER,**

**ECOSTAR ECO 1.0, ECO 2.0, ECO 30.0 Square Body Light Oil** burners are prepared and manufactured according to the latest technical developments and safety rules. It is easy to use for our customers.

We recommend that you read this manual and safety warnings thoroughly before the use of the device in order to ensure safe, cost effective and environmental-friendly use.

If you encounter any issue that is not explained clearly in this manual or you could not understand, please contact with our service department.

We thank you for choosing ECOSTAR brand.

Ecostar Light Oil Burners are manufactured in accordance with TS EN 267 standards.





This Operating Manual is an integral part of the burner and must be maintained in a plastic dossier and hung at a clearly visible place in the burner room.

## CONTENTS

1. WARNINGS .....	3
1.1. Warning Symbols and Descriptions .....	3
1.2. General Safety Rules .....	4
2. TERMS OF WARRANTY .....	6
2.1. Out of Warranty Conditions .....	6
3. BURNER'S GENERAL FEATURES .....	7
3.1. Purpose of Use and Work Limits of Burners .....	7
3.2. Code Key .....	7
3.3. Burner Components .....	9
4. TECHNICAL DATA .....	11
4.1. Capacity Table .....	11
4.2. Back Pressure-Capacity Diagrams .....	12
4.3. Burner Dimensions .....	15
4.4. Flame Length and Diameter .....	15
4.5. Noise Level .....	15
5. BURNER HANDLING INFORMATION .....	16
6. INSTALLATION .....	17
6.1. Burner Installation Picture .....	17
6.2. In reverse flame front mirror boilers .....	18
6.3. In cylindrical (straight flame) boilers .....	18
7. COMMISSIONING .....	19
7.1. Before Commissioning .....	19
7.2. General Controls .....	19
7.3. Combustion Adjustment .....	20
7.4. Fuel Pumps .....	20
7.5. Servomotor Adjustment .....	22
7.6. Emission Measurement .....	22
7.7. Program Relay .....	23
7.8. Light Oil Burner Fuel Ring Line .....	24
8. MAINTENANCE .....	25
8.1. Weekly Maintenance .....	25
8.2. Monthly Maintenance .....	25
8.3. Seasonal Maintenance .....	26
8.4. Installation and Disassembly Instructions for Maintenance Purposes .....	27
9. TROUBLESHOOTING .....	29
10. PERIODICAL FLUE GAS MEASUREMENT REPORT .....	30
11. AFTER SALES SERVICES .....	31
12. NOTES .....	32

## 1. WARNINGS

### 1.1. Warning Symbols and Descriptions

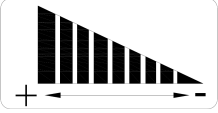
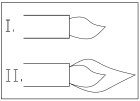
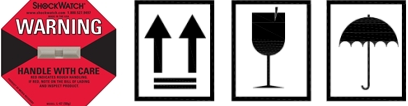
Symbols	Symbol Descriptions
	Important information and useful hints.
	Warning of danger to life or property.
	Warning of electrical voltage.
	Product handling information.
	Flame tube adjustment
	1st and 2nd Stage selection switch
	Carry in an upright position. Fragile Item. Protect against water.

## 1.2. General Safety Rules

- All personnel engaged in installation, disassembly, commissioning, operation, control, maintenance and repair should have received the necessary training and fully read and understood this manual.
- No changes that might damage the safety of the burner unit must be made by persons and/or organizations on the burner unit.
- All operation, commissioning and installation works (except for burning adjustment) should be carried out when the burner is not operating and after disconnecting the power supply. Noncompliance with these rules may lead to serious bodily injuries and even death by electrical shocks or uncontrolled flame formation.
- Repairs concerned with safety elements should be carried out only by the manufacturing company.
- The device should never be used by children, mentally handicapped and inexperienced persons.
- Children must not be allowed to play with the device.
- Keep the device away from explosive and flammable materials.
- Device must intake air, ventilation and air discharge holes must not be closed.



Do not store any inflammable materials in boiler room.



Wear hearing protectors if there is noise in boiler room.



**In case of fire or other emergency;**

- Switch off the main switch
- Take appropriate actions





Install burner firmly. Vibration may damage burner or its components.



Keep boiler doors closed while starting burner and during burner operation.

 Check combustion values to be correct by using flue gas analysis at the whole adjustment range between minimum, full load, and ignition load.

 Use lifting device or belt for lifting fan motor, if necessary.

 During the first commissioning of the burner or in case of any revision carried out in the electrical system or motor cables by any reason, direction of the fan rotation must certainly be checked by the authorized technical service.

 For products that have not been commissioned or started more than 6 months, before activating the servomotor;

In air dampers and oil regulators, servomotor and air damper connections must be checked to ensure that they are free running in spite of immobility and oil freezing.

## **BURNER ROOM**

Install the burner in a suitable room/floor with minimum external air openings and sufficient to ensure perfect combustion, in compliance with current regulations.

Never obstruct air openings of the burner room, burner fan intake vents or air ducts in order to prevent:

- a. The build up of toxic / explosive gas mixtures in the burner room,
- b. Combustion with insufficient air, resulting in hazardous, anti-economical and polluting operation.

The burner must be always protected from rain, snow and frost to prevent corrosion and paint deformations.

Keep the burner room clean and free of solid volatile substances, which could be sucked into the fan and clog the internal burner or combustion head air ducts.

## 2. TERMS OF WARRANTY

Main and auxiliary equipment and all components used in Ecostar light oil burners are guaranteed for 1 year by TERMO ISI SIST. A.Ş starting from the date of commissioning under the maintenance, adjustment, operating conditions and relevant mechanic, chemical and thermal effects explained herein.



Please note that this warranty is only valid if the device(s) is commissioned and maintained by our authorized services.



Our company reserves the right to make any modifications on the product and all instructions thereof for improvement purposes.

### 2.1. Out of Warranty Conditions

- Any damage arising out of or in relation to customers' non-compliance to their responsibilities with regards to installation, commissioning, operation and maintenance,
- Any damage arising out of or in relation to commissioning, repairs and maintenance carried out by unauthorized services,
- Any damage that may occur during transportation or storage of the product,
- Not preserving the product in its original packaging until the installation stage,
- Incorrect and poor electrical connections, Failures due to incorrect voltage applications, frequent repetition of voltage fluctuations,
- Any damage that may occur as a result of incorrect fuel usage or, foreign substances in the fuel used or using of the product without any fuel,
- Any damage that may occur due to foreign particles entered into the product during installation and operation,
- Failures due to incorrect device selection,
- Any damage to unit due to natural disasters,
- Devices without any warranty certificates,
- Warranty Certificates without the stamp and signature of the authorized dealer or service,
- Devices with any falsification on the warranty certificate or without an original serial number.
- The risks during transportation of device under the responsibility of customer belong to the customer.
- Presence of misuse faults are indicated in the reports issued by authorized service stations or our authorized agent, dealer, representative or our factory in case of unavailability of authorized service stations.
- Customers may apply consumer protection arbitrator committee with regards to this report and request for an expert report.

### 3. BURNER'S GENERAL FEATURES

ECOSTAR light oil burners are designed to operate with oil at 2.5 – 6 Cst (mm<sup>2</sup>/s) viscosity, at rated capacity and pressure ranges and -15% to +10% nominal voltage.

#### 3.1. Purpose of Use and Work Limits of Burners

- This product works at any load value equivalent to its max. capacity or covered by its capacity range;
  - In hot water and steam boilers,
  - In direct and indirect hot air generators,
  - Industrial appliances operating at temperature below 600 °C,
  - -15 °C...+60 °C ambient temperature range,
  - 1N 230 VAC/3N 380VAC /50 Hz feed voltage (-%15...+%10) values,
  - Max. 95% relative humidity,
  - In well-ventilated open and closed spaces compatible with protection class IP 40.



This device must never be operated with open flame!

#### 3.2. Code Key

ECO 1.0 G c 2 a  
 1            2            3            4            5            6

**1: ECOSTAR**

**2: Burner Body**

1.0,2.0,30.0 (Square Body)

**3: Fuel Type**

**G** : Gas

**O L**: Light Oil

**4: Engine Speed**(2800 rpm)

**5: OperatingType**

**1**: One Stage

**2**: Two Stage

**6: Capacity Range** (a,b,c,H,L)



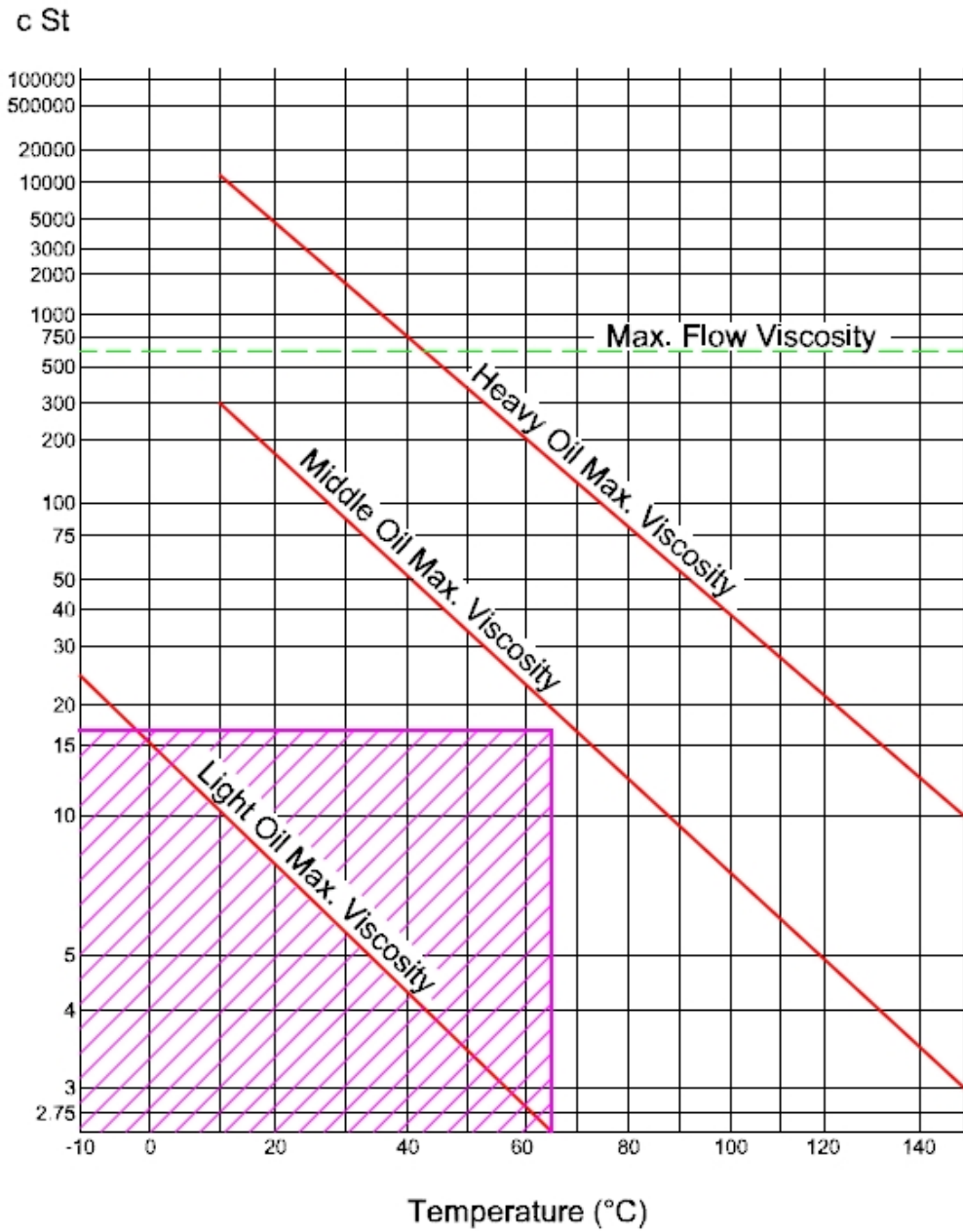

Temperature change of fuel used in ECOSTAR light oil burners dependent on viscosity



Operating Range

### 3.3. Burner Components

#### ECO 1.0

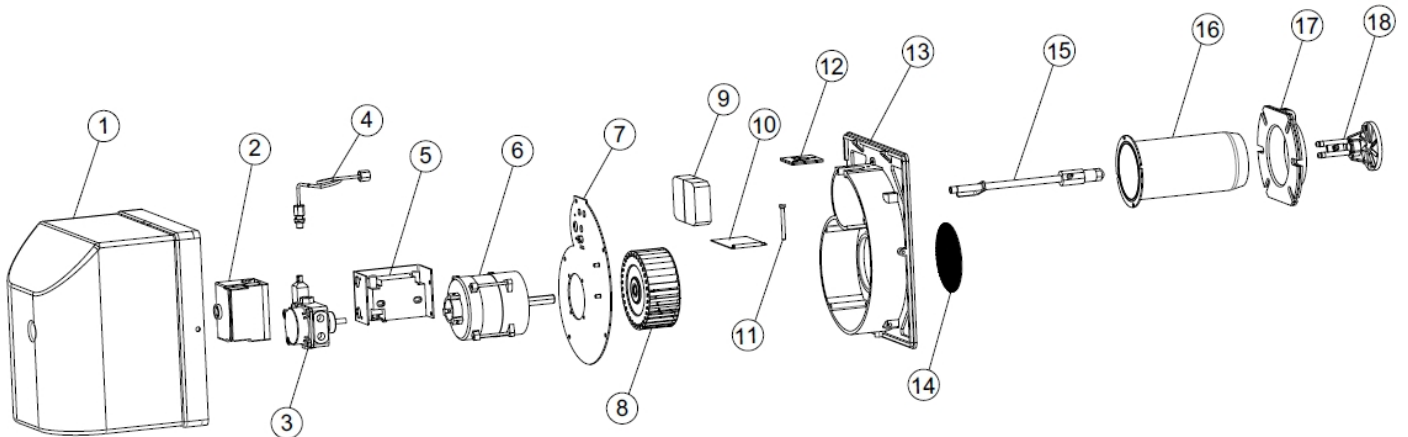

Assembly No	Part Name	Assembly No	Part Name
1	Housing cover	10	Air klappe
2	Relay	11	Air klappe adjusting screw
3	Fuel pump	12	Cover
4	Pump-lance connecting group	13	Body
5	Ignition transformer	14	Filter
6	Motor	15	Lance
7	Installation sheet	16	Flame tube
8	Fan	17	Boiler connection flange
9	Electric connection socket	18	Diffuser

**ECO 2.0-ECO 30.0**

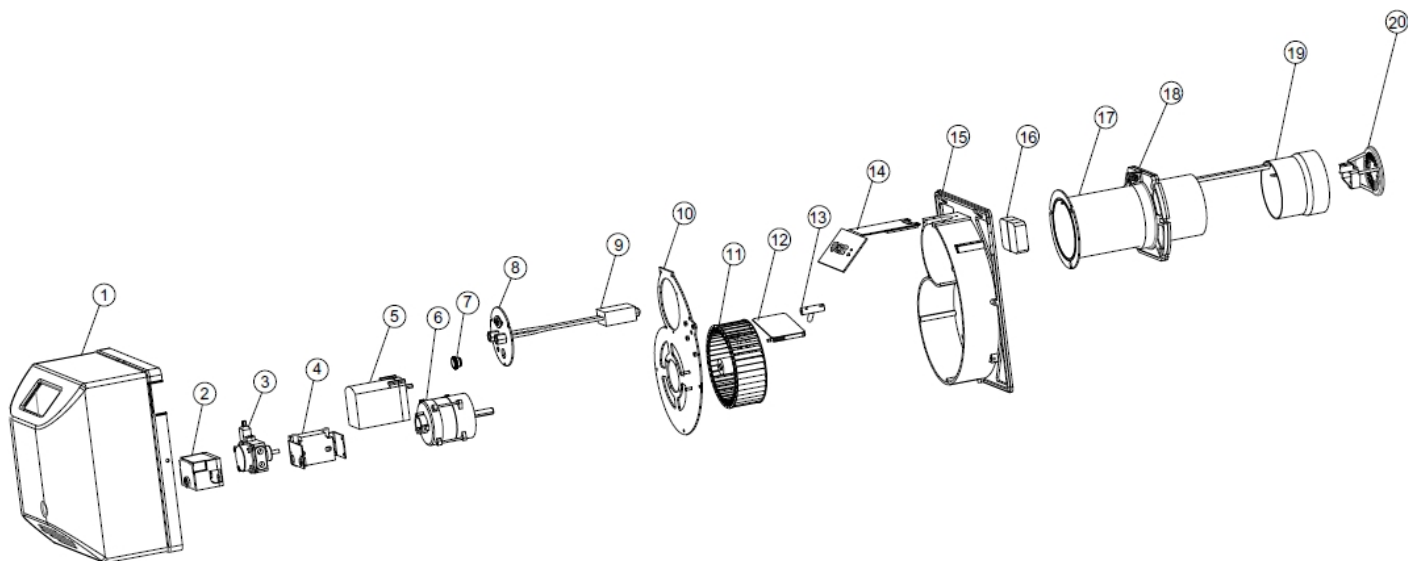

Assembly No	Part Name	Assembly No	Part Name
1	Housing cover	11	Fan
2	Relay	12	Air klappe
3	Fuel pump	13	Air klappe drive shaft
4	Ignition transformer	14	Electric installation sheet
5	Servomotor	15	Spiral casing
6	Motor	16	Electric connection socket
7	Bulls eye	17	Flame tube
8	Service cover	18	Boiler connection flange
9	Lance	19	Flame tube extension
10	Installation sheet	20	Diffuser

## 4. TECHNICAL DATA

### 4.1. Capacity Table

<b>SQUARE BODY MONOBLOCK LIGHT OIL BURNERS CAPACITY TABLE</b>								
BURNER TYPE	CAPACITY		CAPACITY		LIGHT OIL CONSUMPTION		FAN MOTOR POWER	MAIN SUPPLY
	Min. Kcal/h	Max. Kcal/h	Min. kW	Max. kW	Min. Kg/h	Max. Kg/h	kW	VAC
<b>ONE STAGE LIGHT OIL BURNERS</b>								
ECO 1.0 OL C 1	10.200	35.700	12	42	1,0	3,5	0,15	1N 230
ECO 1.0 OL C 1 a	15.300	51.000	18	59	1,5	5,0	0,15	1N 230
ECO 1.0 OL C 1 b	20.400	71.400	24	83	2,0	7,0	0,15	1N 230
ECO 1.0 OL C 1 c	25.500	84.660	30	98	2,5	8,3	0,15	1N 230
ECO 2.0 OL C 1	59.976	132.600	70	154	5,9	13,0	0,15	1N 230
ECO 2.0 OL C 1a	71.400	173.400	83	202	7,0	17,0	0,15	1N 230
ECO 2.0 OL C 1b	81.600	214.200	95	249	8,0	21,0	0,25	1N 230
ECO 2.0 OL C 1c	107.100	265.200	125	308	10,5	26,0	0,25	1N 230
<b>TWO STAGE LIGHT OIL BURNERS</b>								
ECO 2.0 OL C 2	59.976	132.600	70	154	5,9	13,0	0,15	1N 230
ECO 2.0 OL C 2a	71.400	173.400	83	202	7,0	17,0	0,15	1N 230
ECO 2.0 OL C 2b	81.600	214.200	95	249	8,0	21,0	0,25	1N 230
ECO 2.0 OL C 2c	107.100	265.200	125	308	10,5	26,0	0,25	1N 230
ECO 30.0 OL C 2	112.200	306.000	130	356	11	30	0,25	1N 230
ECO 30.0 OL C 2a	132.600	387.600	154	451	13	38	0,55	1N 230
ECO 30.0 OL C 2b	142.800	469.200	166	546	14	46	0,55	1N 230
ECO 30.0 OL C 2c	163.200	530.400	190	617	16	52	0,55	1N 230

$H_u$  Light Oil (L) = 10200 Kcal/kg

## 4.2. Back Pressure-Capacity Diagrams

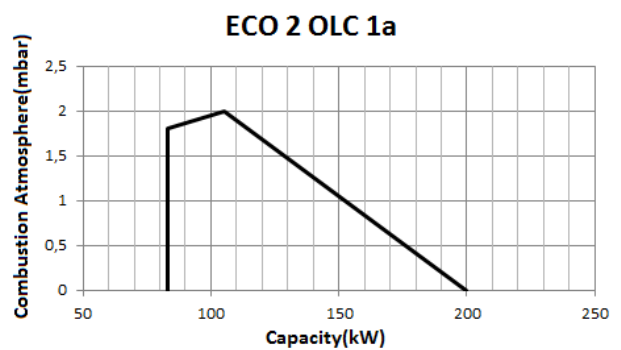
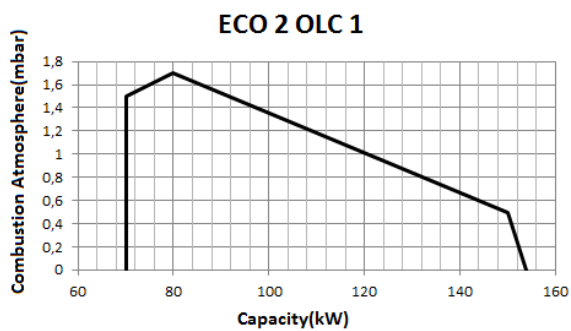
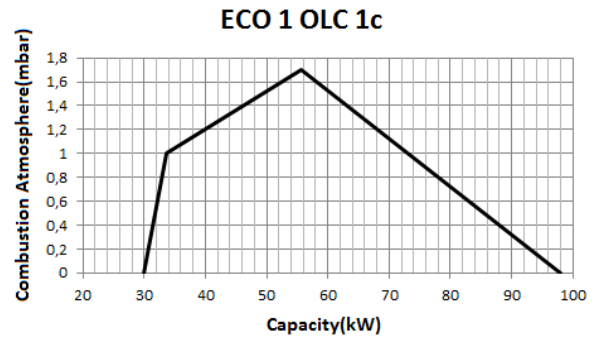
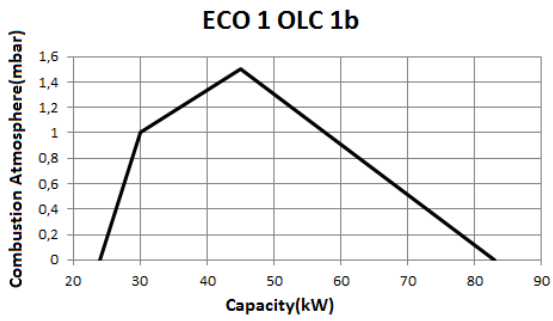
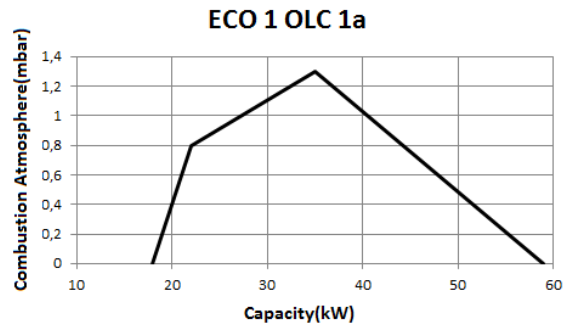
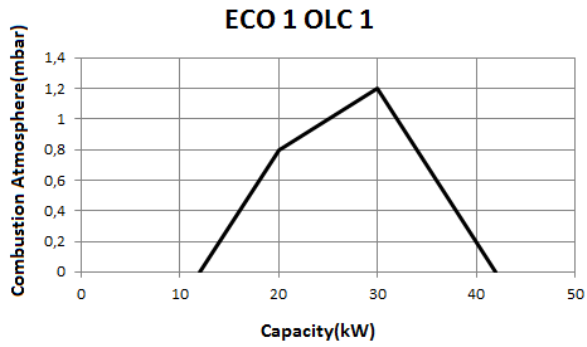

**ECO 2 OLC 1b**

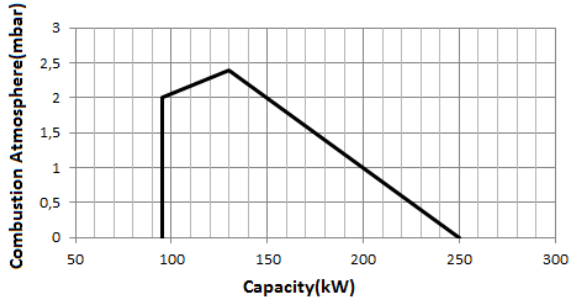

**ECO 2 OLC 1c**

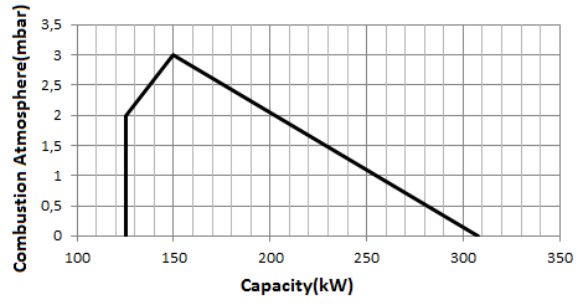

**ECO 2 OLC 2**

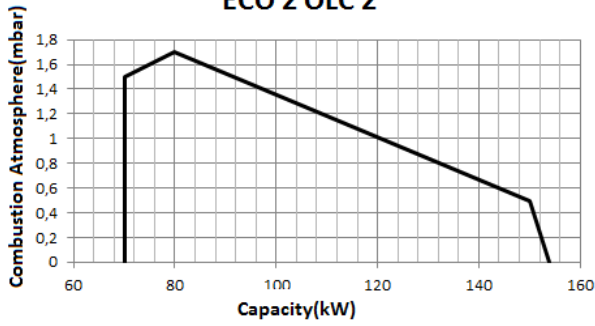

**ECO 2 OLC 2a**

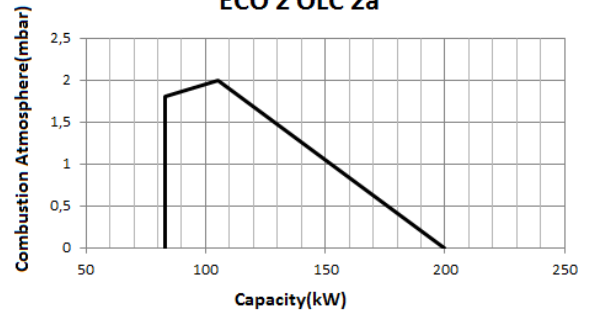

**ECO 2 OLC 2b**

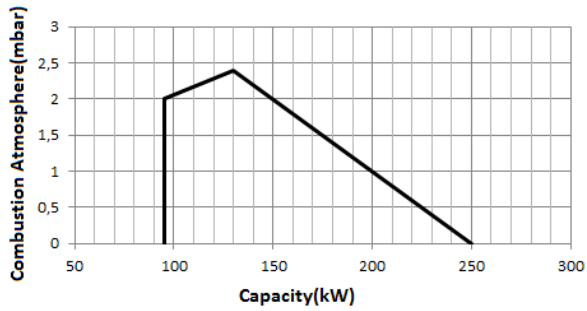

**ECO 2 OLC 2c**

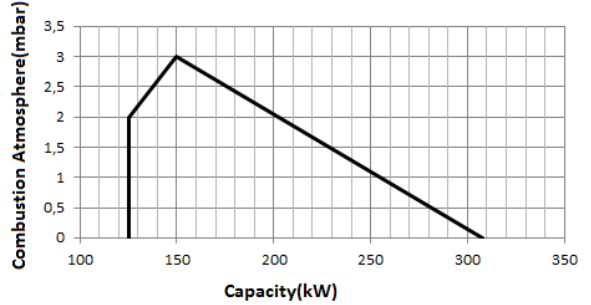

**ECO 30 OLC 2**

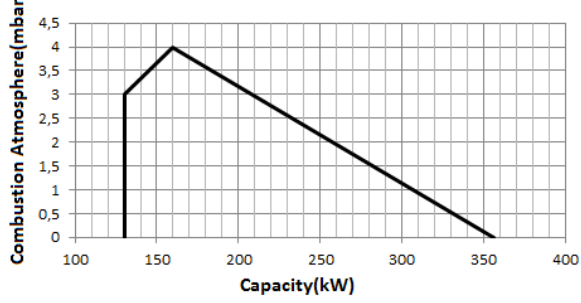

**ECO 30 OLC 2a**

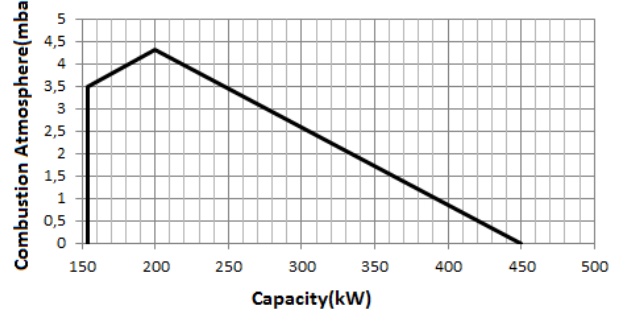

**ECO 30 OLC 2b**

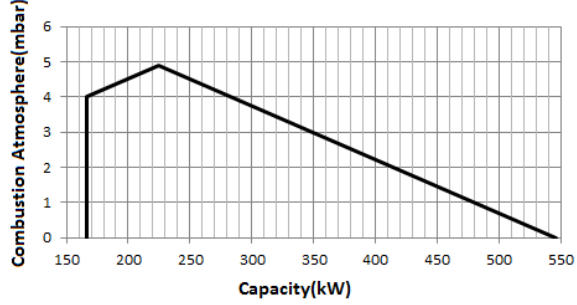

**ECO 30 OLC 2c**

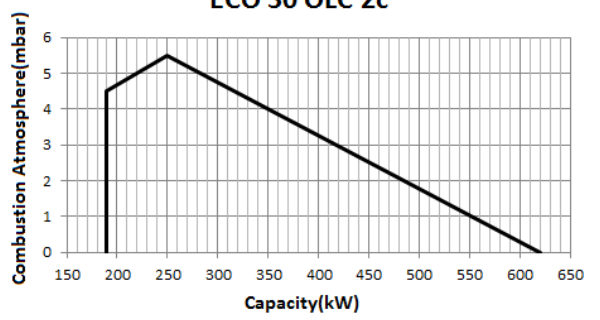

### 4.3. Burner Dimensions

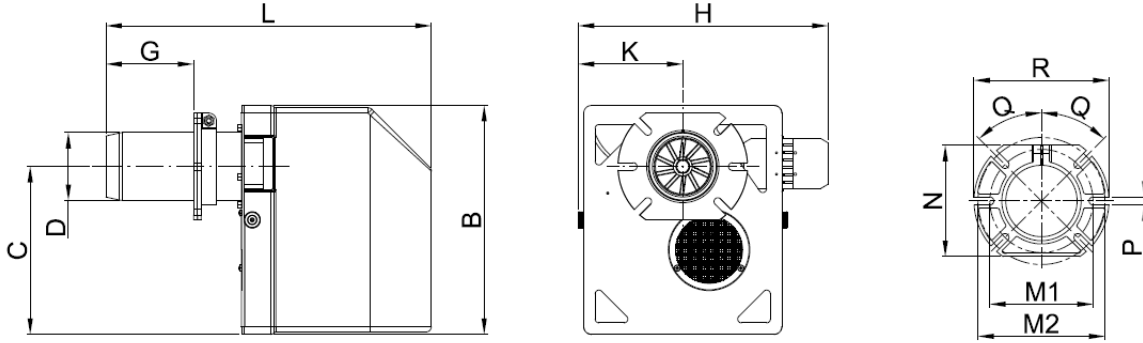

	L	Gmin	Gmax	H	K	B	C	D	M1	M2	N	R	P	Q
ECO 1.0 OL	430	50	125	330	138	300	220	89	130	160	140	170	10	45
ECO 2.0 OL	625	80	250	398	172	400	295	134	195	220	185	230	10	45
ECO 30.0 OL	700	100	270	455	202	480	350	153	195	220	185	230	10	45

### 4.4. Flame Length and Diameter

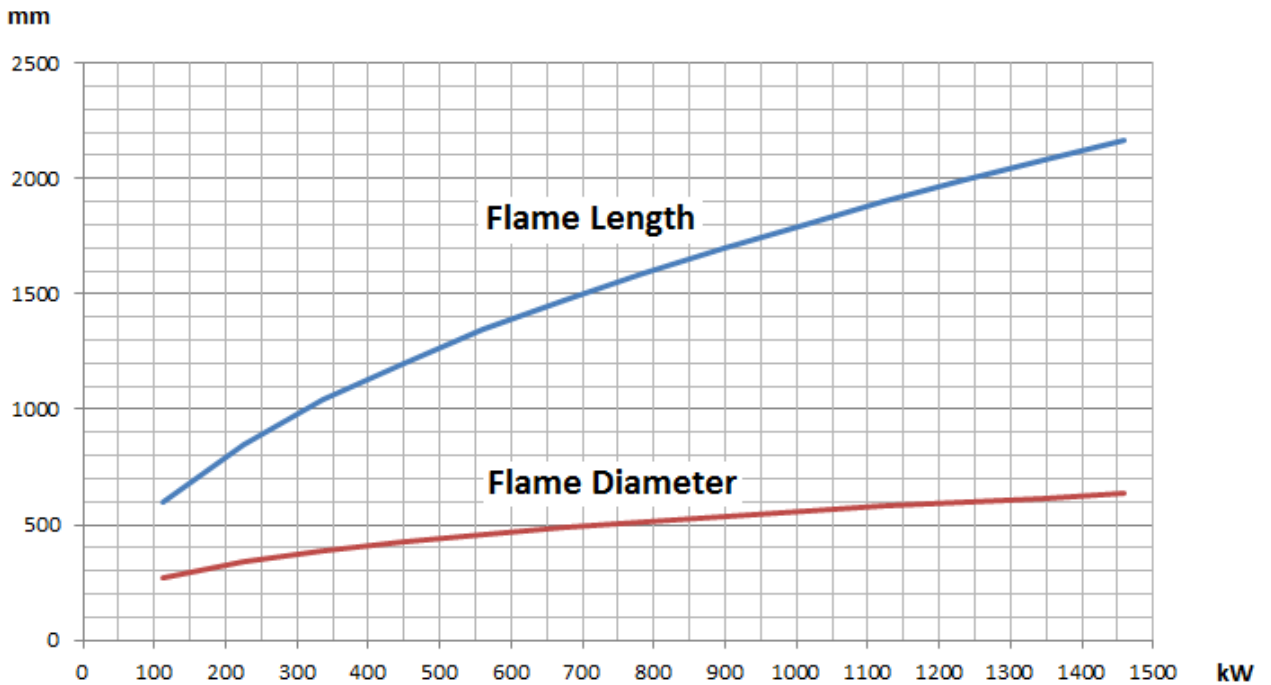

### 4.5. Noise Level

Product operates within the range of 70 decibels max. and 74 decibels.



## 5. BURNER HANDLING INFORMATION

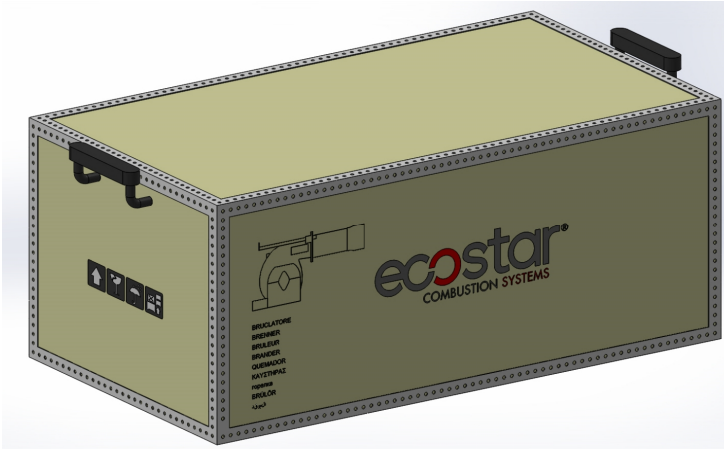

- Lift the product by holding the handles as seen in the picture.
- Prevent strong impacts on top of the product and vibration while handling the product.
- Do not leave the product in wet environment.



Dimensions of the box used for handling

Burner	L x W x H (cm)	Weight (kg)
ECO 1.0	70 X 33 X 35	24
ECO 2.0	65 X 36 X 47	36
ECO 30.0	75 X 43 X 54	36

## 6. INSTALLATION

### 6.1. Burner Installation Picture

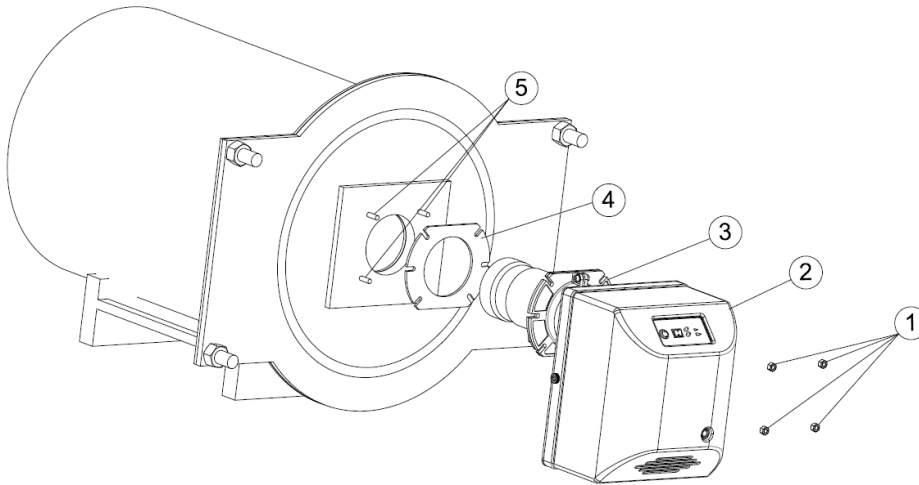

- 1- Drift Bolts
- 2- Burner Body
- 3- Boiler Connection Flange
- 4- Gasket
- 5- Boiler Studs

- Ø In the installation of the burner, use the installation materials supplied with the burner.
- Ø Secure the burner connection flange onto the burner cover by 4 bolts. Gasket must be connected such that it will remain between connecting flange and boiler cap.

#### **After completing the installation of the burner on the boiler:**

- Ø Connect the oil feed pipes.
- Ø Connect the burner panel to the mains by a cable suitable for the rated power.



Clean the inside of fuel line thoroughly before installing the burner to the fuel line. Any damage that may occur due to solid objects and metal particles from the fuel line shall not be covered by our company.

### 6.2. In reverse flame front mirror boilers

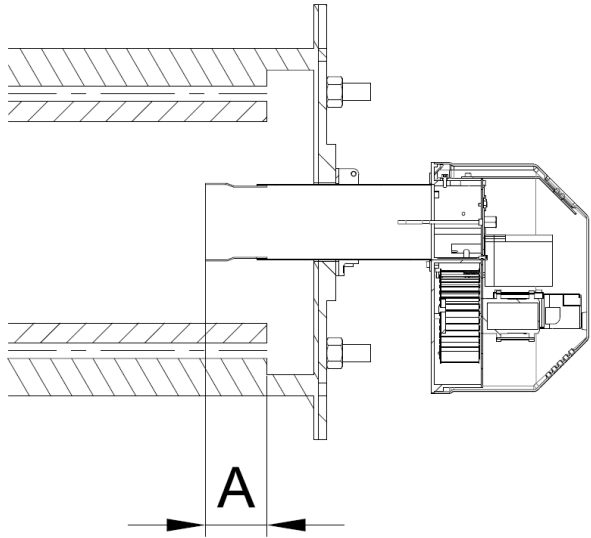

While installing the burner in reverse flame front mirror boilers, flame tube tip must be adjusted such that it gets inside by 50 mm-100 mm from flue pipes ( $50\text{mm} \leq A \leq 100\text{mm}$ ). Otherwise flue gas temperature will rise and fuel consumption will increase.

### 6.3. In cylindrical (straight flame) boilers

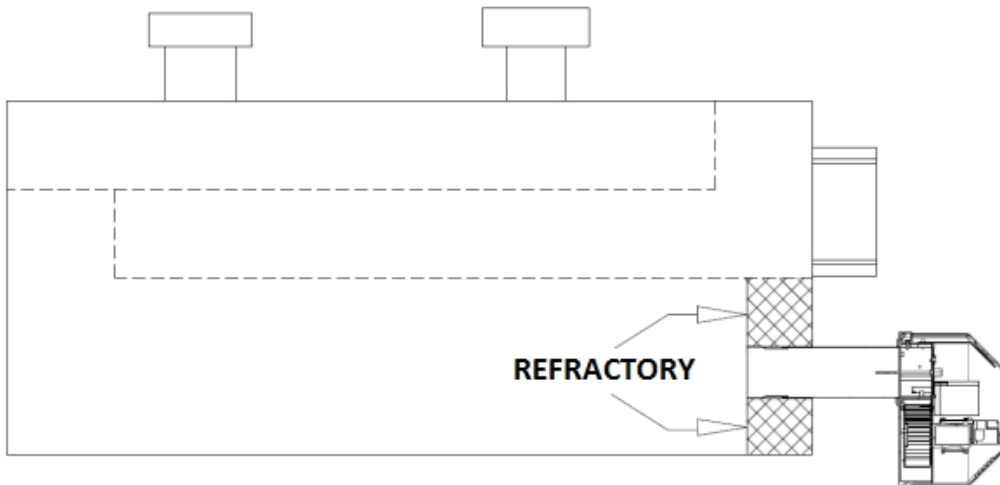

## 7. COMMISSIONING

### 7.1. Before Commissioning



#### Electrical connection

Perform electrical connections according to the diagram provided with the burner. Follow general security rules during installation of electric wiring and making connections. Connect the earthing terminal in electric panel to the earthing installation.

### 7.2. General Controls



Make sure to perform the following controls before commissioning the burner.

- Ø Installation of the burner to the boiler is checked.
- Ø Check the fuel line (are the pipe diameters and the pipe installation correct?).
- Ø Check energy input cables and voltages.
- Ø Check the boiler safety thermostats and, if it is a two-stage burner, then make sure that there are two thermostats.
- Ø Check the fuel nozzles according to the boiler capacity.
- Ø Prior to operating the burner, control the boiler water level.
- Ø Make sure water circulation system is turned on, and steam boiler and water feed pumps and boiler inlet - outlets are open.

#### Commissioning order

- Ø After performing the above mentioned controls, open the fuel tank valve.
- Ø Open the valve upstream of the fuel filter.
- Ø Check direction of motor rotation.
- Ø Open the pump's vent plug and place the manometer (0-40 bar).
- Ø Turn on the burner switch (turn to position 1).
- Ø When the burner starts up, the motor is activated and turns the pump at the same time.
- Ø It actuates pre-purge and discharges the residual gases remaining in the boiler from the funnel.
- Ø After the pre-purge, fuel is delivered from the nozzle. The fuel meets the flame from the ignition electrodes and the combustion starts.
- Ø After combustion of the burner, the pump pressure is adjusted (light oil: 14 bar).
- Ø If the burner has two stages, the switch is brought to position "2", and the capacity of the burner is increased through servomotor. Ideal combustion is obtained by increasing the amount of air by the fuel given according to analyses value.
- Ø The boiler thermostat is adjusted as desired (70-90°C for central heating boilers).
- Ø For the safety of the system, check the boiler thermostats and observe the deactivation of the burner.

### 7.3. Combustion Adjustment

#### Ø Fuel nozzle

Use proper wrench in installation and dismantle of the fuel nozzle.

Use diesel oil to clean the fuel nozzle. Do not use thinner and its derivatives.

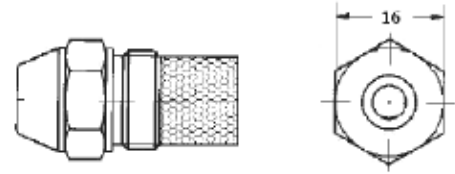

#### Ø Photocell

Check the photocell weekly. Clean the dust or fume stains on the glass of photocell by a dry cloth.



### 7.4. Fuel Pumps

#### A2L Type

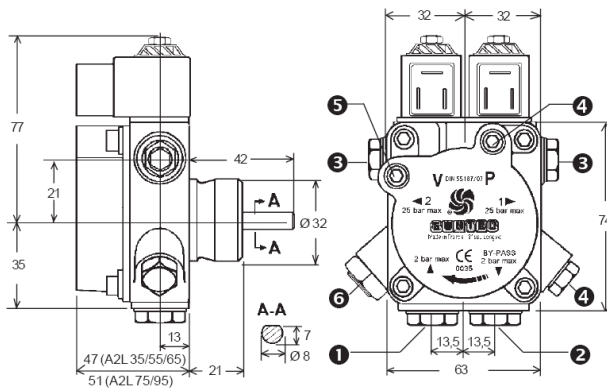

1. Fuel suction connection
2. Return and by-pass connection
3. Fuel outlet connection
4. Manometer connection
5. Vacuum measurement connection
6. Pressure adjustment

**Ø One Stage Light Oil Burner Fuel Circuit**

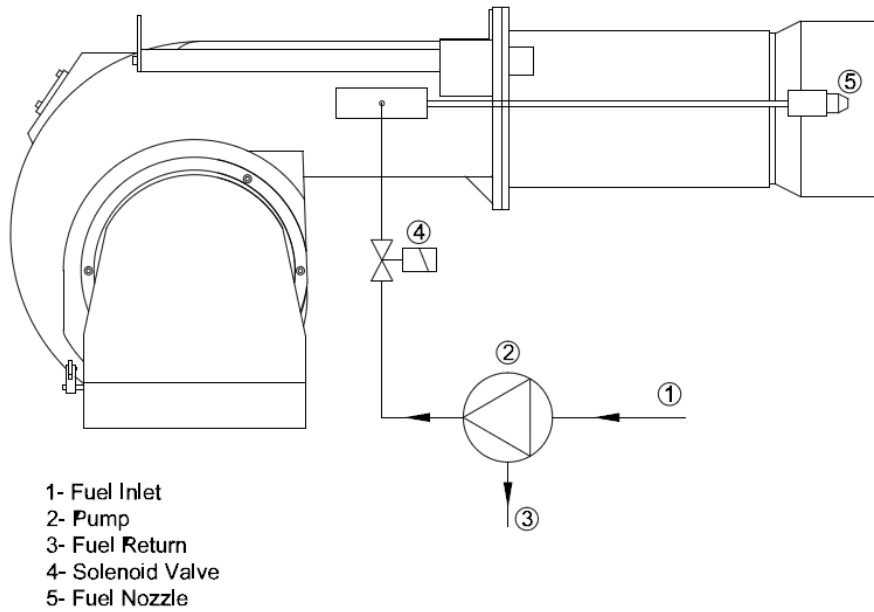

**Ø Two Stages Light Oil Burner Fuel Circuit**

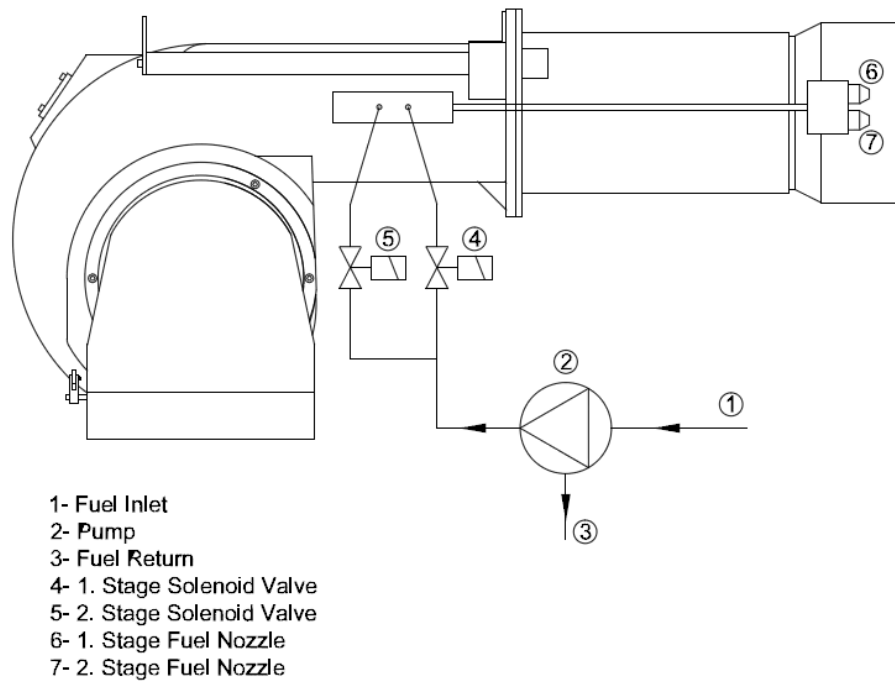

## 7.5. Servomotor Adjustment

Ø SQN70

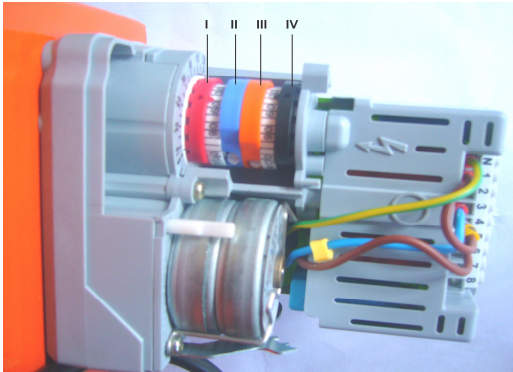

### At Two-stage Burners;

- I. Red Cam: Adjusts 2nd level max. air.
- II. Blue Cam: Resets the clamp.
- III. Orange Cam: Adjusts 1st level min. air.
- IV. Black Cam: Adjusts 2nd level valve opening degree.



Do not open servomotor. Do not interfere with. It may damage servomotor or change burner settings.

## 7.6. Emission Measurement

In emission measurements, the following values are accepted as reference according to TS EN 267 standard.

- Ø  $CO < 110 \text{ mg/kWh}$
- Ø  $\%3 \leq O_2 \leq \%5$
- Ø  $NO_x < 250 \text{ mg/kWh}$
- Ø Excess air ratio  $1,2 \leq \lambda \leq 1,3$



It is important for the boiler to be sealed in order to avoid incorrect measurements during emission measurements.



Boiler temperature must be between 40 C° and 80 C° while making emission measurement in hot water boilers.

## 7.7. Program Relay

### LOA 24

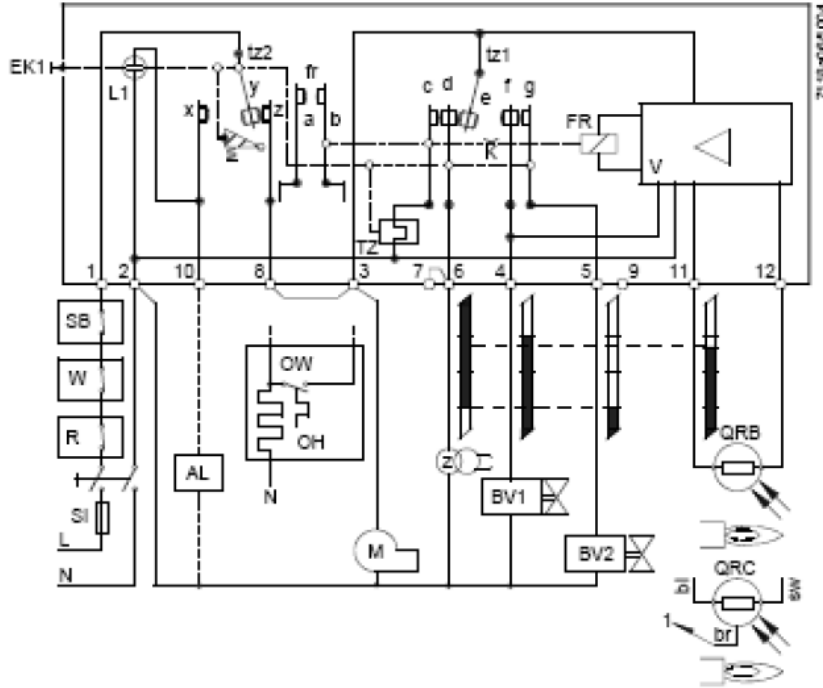

∅ Red led on: Indicates burner malfunction.

∅ If the burner switches to the fault mode, please wait at least 30 seconds and reset the program relay.



Press and hold the light button for 2 sec. to reset the program relay.



**7.8. Light Oil Burner Fuel Ring Line**

Tank is above the burner level.

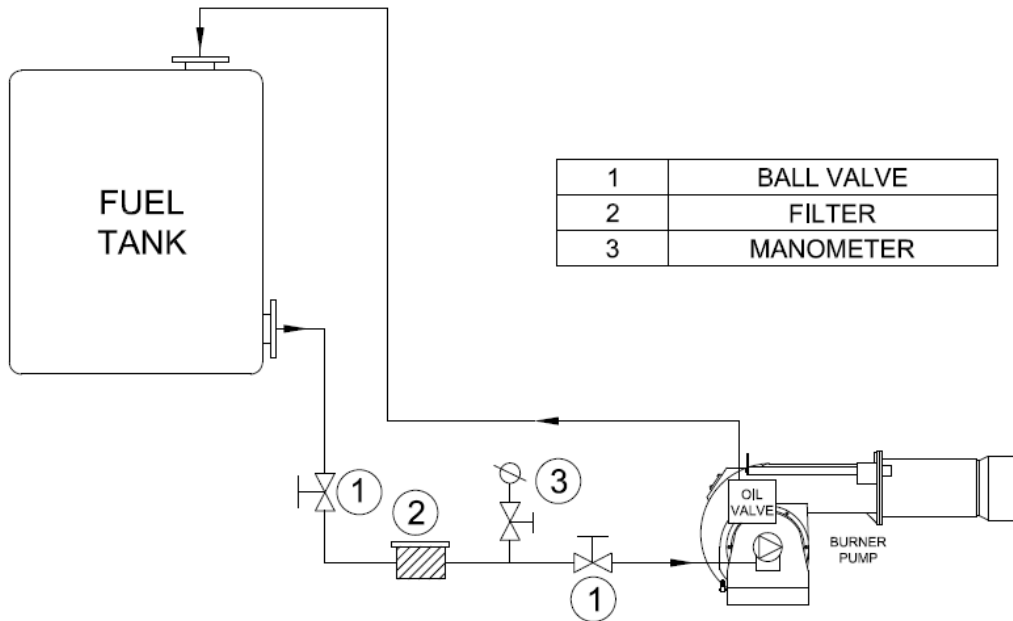

Tank is below the burner level.

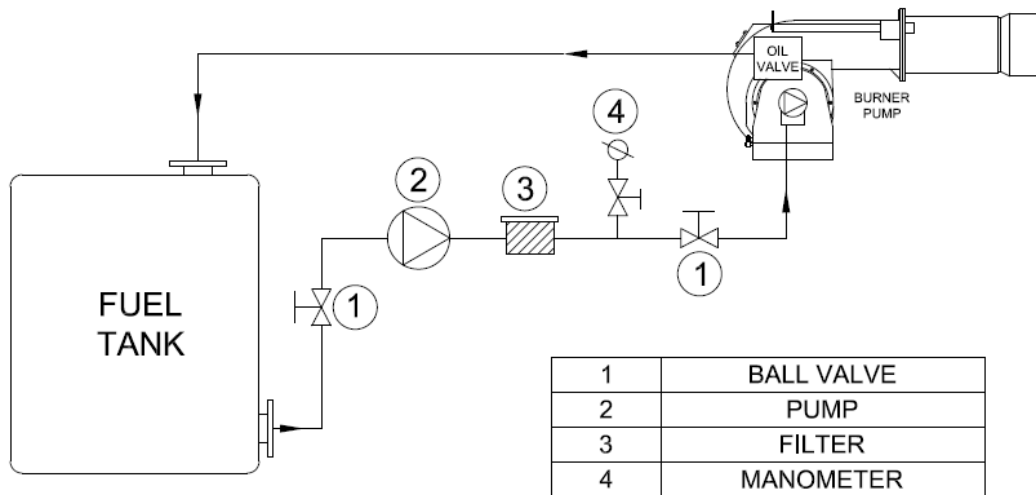

## 8. MAINTENANCE

### 8.1. Weekly Maintenance

Weekly maintenance is a routine cleaning and adjustment procedure which is performed to ensure smooth and continuous operation of the system. Burner components must be adjusted after each maintenance work in accordance with the instructions. Otherwise, the burner cannot be operated efficiently.

- Ø Clean all filters in fuel ring system.
- Ø Clean fuel nozzle of the burner.
- Ø If the fin spaces and surface of the diffuser are covered with particles and formed a layer, clean it with a wire brush.
- Ø Clean heads of ignition electrodes. Check by performing manual ignition, adjust the distance between the ignition electrode and diffuser according to the adjustment instructions.

### 8.2. Monthly Maintenance

Monthly maintenance is a more comprehensive maintenance compared to weekly maintenance, where general checks of burner and peripheral components are performed to prevent possible faults. After completion of maintenance and adjustment processes, make sure to perform a combustion analysis.

- Ø Clean the filters on the fuel line to the burner.
- Ø Clean fuel nozzle of the burner.
- Ø Clean the surface of the diffuser.
- Ø Clean flame pipe.
- Ø Check all wiring points. Tighten loose connections.
- Ø Clean the solenoid valves.
- Ø Clean the photocell.
- Ø Clean the dust and layers accumulated on the fan and air valves.
- Ø Check pump pressure. Check if necessary (Light Oil: 14 bar)
- Ø Check ignition electrodes. Adjust it if necessary. Check ignition cables and sockets.
- Ø Perform cleanliness control of inside panel. Clean if necessary.
- Ø Check all bolts of the burner. Tighten loose bolts.
- Ø After starting the burner and adjusting air klappe, perform flue gas analysis and check if there is an ideal combustion.

### **8.3. Seasonal Maintenance**

Comprehensive maintenance work when the burner is re-started after long periods of shut-down or interruptions. After completion of maintenance and adjustment processes, make sure to perform a combustion analysis.

- Ø Check insulation resistance of electric motor.
- Ø Make surface cleaning of ignition electrodes and porcelains. Replace cracked or broken porcelains.
- Ø Clean air fan and clamps.
- Ø Check the operating function.
- Ø Check cleanliness of the nozzle. Replace it if necessary.
- Ø Clean the N.C. solenoid valve. Measure the coil winding resistance.
- Ø Clean the strainer (filter) under the pump cover.
- Ø Clean the photocell.
- Ø Clean fuel filter. Replace it if necessary.
- Ø Check boiler thermostats.
- Ø Check cleanliness of boiler inside and clean if necessary.

## 8.4. Installation and Disassembly Instructions for Maintenance Purposes

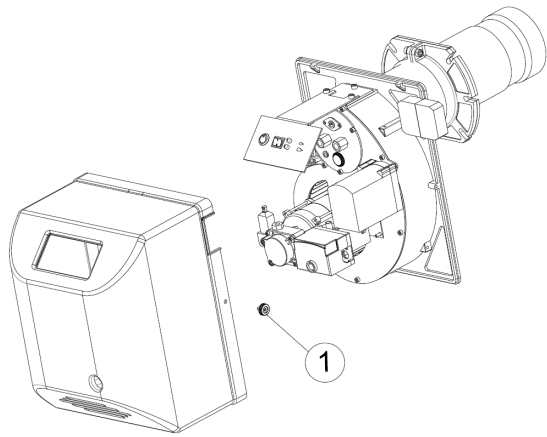

1. Remove 2 bolts on burner top cover and detach the top cover from the body.

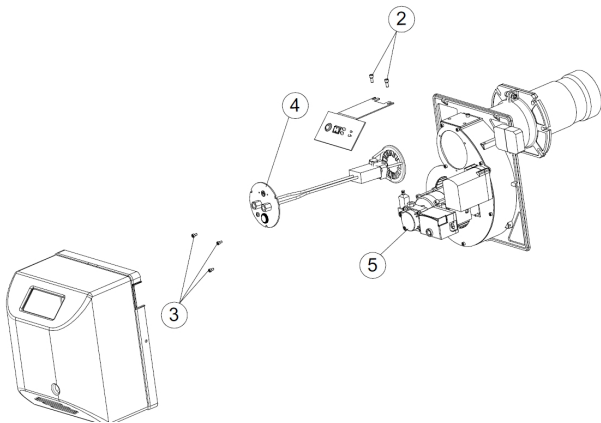

2. Remove bolts number 2 on the 2nd electric installation sheet.
3. Remove bolts number 3 on service cover and detach the installation sheet from the spiral casing.
4. Take out the nozzle group and perform its maintenance (Clean electrodes, diffuser and fuel nozzles).
5. Remove and clean the fuel pump number 5

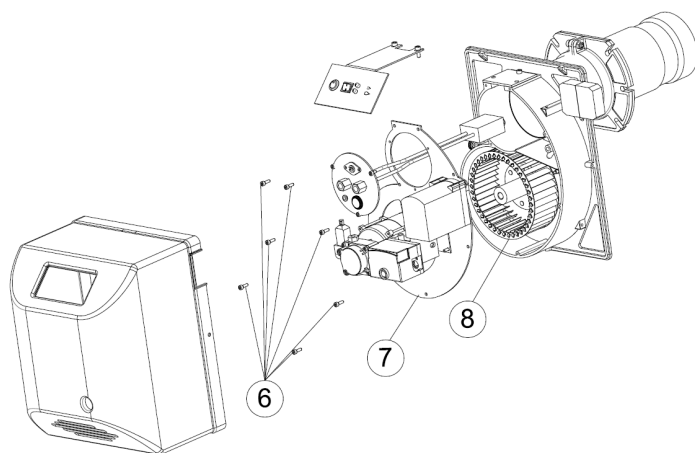
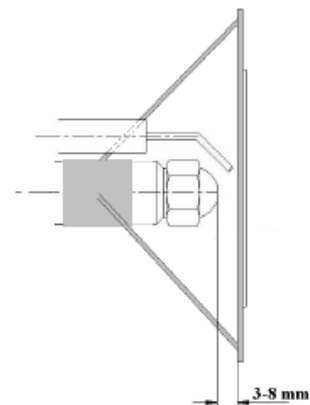
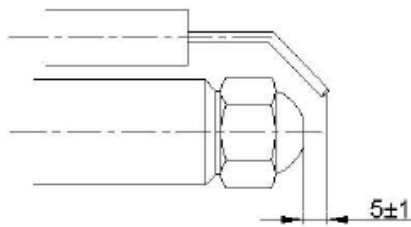
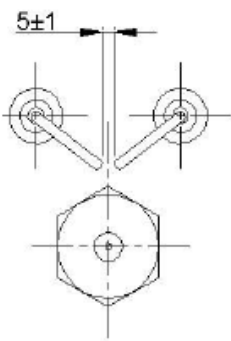

6. Remove bolts number 6 on the installation sheet.
7. Detach the installation sheet from the spiral casing.
8. Perform maintenance of the fan group.



Perform the installation by following the reverse of the method you have followed during disassembly.



Be careful to connect the components correctly during installation after maintenance

## 9. TROUBLESHOOTING

Problem	Cause	Explanation-Suggestion
Burner cannot be commissioned	Fuel is cut or does not come	Fuel valve might be closed. Open the valve.
	Fuse failure	Check burner power supply. The fuse on the main panel or the fuse on the burner might be tripped.
	Relay failure	Reset the thermal relay. Check adjustment of the thermal relay according to the current in motor label. If the failure is not removed, replace the thermal relay.
	Boiler thermostat, pressure switch failure	If there is a problem with the burner thermostats, pressure switches and steam tank this may be due to an unadjusted or faulty water level device; adjust it and if broken, replace it.
Flame appears and goes into failure mode.	Fuel pressure error	Circuit fuel pressure might have dropped.
	Photocell failure	Photocell may be faulty or contaminated. Remove and clean.
	Program relay failure	Replace it with a new one.
Burner starts up, but fails after 10 seconds.	Program relay failure	Replace it with a new one.
	Fan motor failure	Check fan motor coils, motor contactor and outlet from program relay.
Burner starts up, but fails after 30 seconds.	Fuel valve, fuel pressure drop	Fuel valve might be closed. Supply fuel pressure might be low. Check fuel inlet manometer.
	Ignition electrode failure	Ignition electrodes might be misadjusted or ignition cables might have come out of their terminals. Adjust ignition electrodes with a distance of 3-5 mm. between them.
Boiler cover is overheating.	Sealing problem	Ensure sealing between the boiler cover and burner. If required, use insulating material between the boiler connecting flange and boiler cover.



## 11. AFTER SALES SERVICES

Dear Customer,

We believe that providing a good service is as important as providing a good product. Therefore, we continue offering wide range of comprehensive services to our conscious customers.

Our contact details for your requests and complaints

**Esentepe Mah.Milangaz Cad. No:75 K:3**

**Kartal Monumento Plaza**

**KARTAL/İSTANBUL/TÜRKİYE**

**Tel: +90 216 442 93 00**

**Fax: +90 216 370 45 03**

Factory Contact Details

**Türkgücü OSB**

**Bülent Ecevit Bulvarı No:11**

**ÇORLU/TEKİRDAĞ/TÜRKİYE**

**Tel: +90 282 685 44 80-81**

**Fax: +90 282 685 42 09**

Also you can contact with us:

**Web site : [www.ecostar.com.tr](http://www.ecostar.com.tr)**

**E - mail : [servis@ecostar.com.tr](mailto:servis@ecostar.com.tr)**



Please observe the following recommendations.

- Use the product in accordance with the principles of this manual.
- For any service demands regarding the product, please contact our Service Center from the abovementioned phone numbers.
- Upon your purchase, register your warranty certificate during installation.



