

MONOBLOCK GAS BURNERS INSTALLATION, OPERATING AND MAINTENANCE MANUAL

ONE-STAGE, TWO-STAGE AND MODULATING OPERATION

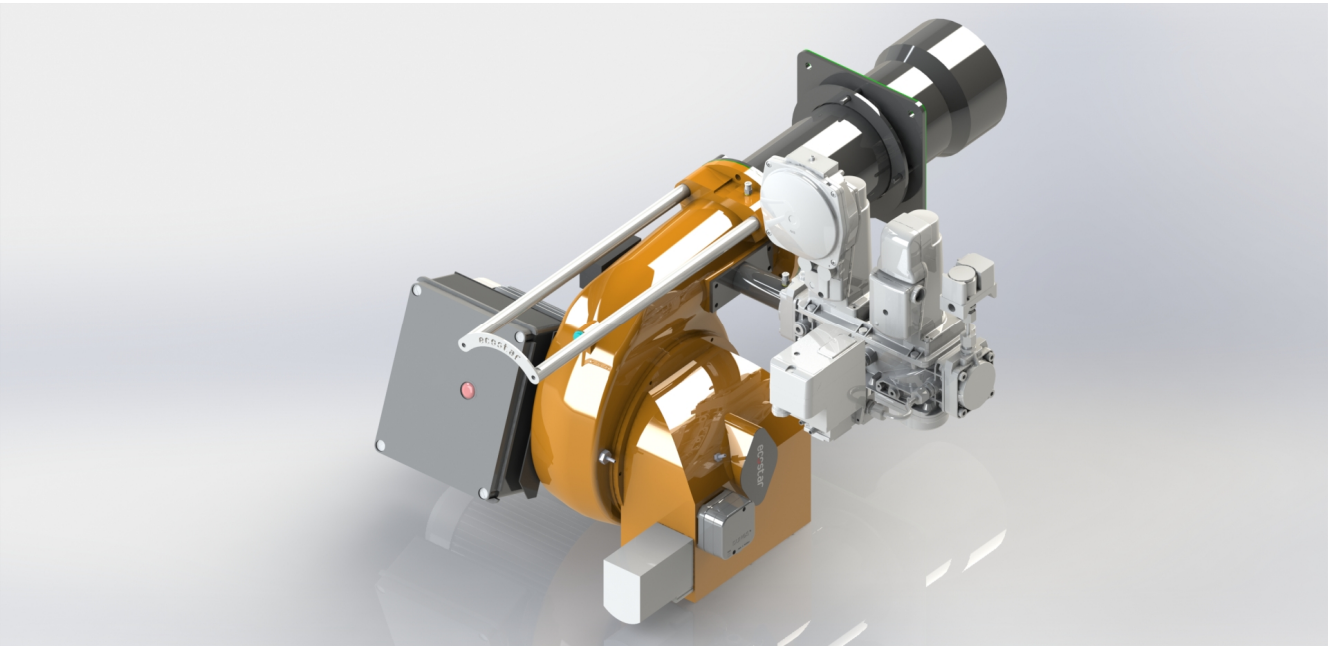

ECO 1
ECO 2
ECO 30
ECO 45

DEAR USER,

ECOSTAR ECO 1, ECO 2, ECO 30, ECO 45 GAS burners are prepared and manufactured according to the latest technical developments and safety rules. It is easy to use for our customers.

We recommend that you read this manual and safety warnings thoroughly before the use of the device in order to ensure safe, cost effective and environmental-friendly use.

If you encounter any issue that is not explained clearly in this manual or you could not understand, please contact with our service department.

We thank you for choosing ECOSTAR brand.

Ecostar Gas Burners are manufactured in accordance with TS EN 676 +A2 standards.

This Operating Manual is an integral part of the burner and must be maintained in a plastic dossier and hung at a clearly visible place in the burner room.



TERMO ISI SİSTEMLERİ SAN.VE TİC.A.Ş.

Esentepe Mah.Milangaz Cad. No:75 K:3

Kartal Monumento Plaza
Kartal/İSTANBUL/TÜRKİYE

Tel: +90 216 442 93 00

Fax: +90 216 370 45 03

www.ecostar.com.tr











e-mail:servis@ecostar.com.tr

CONTENTS

1. WARNINGS.....	3
1.1. Warning Symbols and Descriptions.....	3
1.2. General Safety Rules.....	4
2. TERMS OF WARRANTY	6
2.1. Out of Warranty Conditions	6
3. BURNER’S GENERAL FEATURES.....	7
3.1. Purpose of Use and Work Limits of Burners	7
3.2. Code Key.....	7
3.3. Burner Components	8
4. GAS, FLUE GAS AND HEATING WATER SCHEMA	11
5. TECHNICAL DATA.....	12
5.1. Capacity Table.....	12
5.2. Back Pressure-Capacity Diagrams.....	13
5.3. Burner Dimensions	15
5.4. Gas Hood Pressure Loss Diagram	16
5.5. Flame Length and Diameter	18
5.6. Noise Level.....	18
6. BURNER HANDLING INFORMATION.....	18
7. INSTALLATION	20
7.1. Burner Installation Picture.....	20
8. COMMISSIONING	21
8.1. Before Commissioning.....	21
8.1.1. Ignition and Ionizasyon System.....	21
8.2. General Controls.....	22
8.3. Combustion Adjustment.....	23
8.3.1. Gas Adjustment.....	23
8.3.1.1. VGD 20 4011 - 5011 Series Gas Valve	23
8.3.1.2. MB DLE Series Monoblock Gas Valve.....	23
8.4. Air Pressure Switch Adjustment.....	26
8.5. Servomotor Adjustment	26
8.6. Emission Measurement	27
8.7. Capacity Adjustment.....	27
8.8. Program Relay	28
8.9. Function Controls and Adjustments.....	28
8.10. Final Checks.....	28
8.11. Gas Pass Equipment Required in Gas Line	31
9. MAINTENANCE	32
9.1. Monthly Maintenance	32
9.2. Seasonal Maintenance.....	32
9.3. Installation And Disassembly Instructions For Maintenance Purposes.....	33
10. TROUBLESHOOTING	36
11. PERIODICAL FLUE GAS MEASUREMENT REPORT.....	37
12. AFTER-SALES SERVICES	38
13. NOTES	39

1. WARNINGS

1.1. Warning Symbols and Descriptions

Symbols	Symbol Descriptions
	Important information and useful hints.
	Warning of danger to life or property.
	Warning of electrical voltage.
	Product handling information.
P _F	Impulse connection detecting combustion chamber pressure
P _L	Impulse connection detecting combustion air pressure
P _{BR}	Impulse connection detecting burner gas head
 CLEAN THE GAS BURNER. CLEAN GAS LINE. ЧИСТАЯ ЛИНИЯ ГАЗ.	"Clean the gas line" warning on gas line.
	Electric motor direction of rotation
   	Carry in an upright position. Fragile Item. Protect against water.

1.2. General Safety Rules

- All personnel engaged in installation, disassembly, commissioning, operation, control, maintenance and repair should have received the necessary training and fully read and understood this manual.
- No changes that might damage the safety of the burner unit must be made by persons and/or organizations on the burner unit.
- All operation, commissioning and installation works (except for burning adjustment) should be carried out when the burner is not operating and after disconnecting the power supply. Noncompliance with these rules may lead to serious bodily injuries and even death by electrical shocks or uncontrolled flame formation.
- Repairs concerned with safety elements should be carried out only by the manufacturing company.
- The device should never be used by children, mentally handicapped and inexperienced persons.
- Children must not be allowed to play with the device.
- Keep the device away from explosive and flammable materials.
- Device must intake air, ventilation and air discharge holes must not be closed.



If you sense gas leakage;

- Shut down valves of all gas devices.
- Open all doors and windows.
- Do not turn on electric devices or do not turn them off if they are working.
- Do not use burner derived tools such as match and lighter.
- Inform the gas company.



Do not store any inflammable materials in boiler room.



Wear hearing protectors if there is noise in boiler room.



In case of fire or other emergency;

- Switch off the main switch
- Close the main fuel shut-off valve outside the plant.
- Take appropriate actions



The burner installation must be carried out in accordance with the instructions. Vibration can damage the burner and its components.



Keep boiler doors closed while starting burner and during burner operation.



Check combustion values to be correct by using flue gas analyzer at the whole adjustment range between minimum, full load, and ignition load.



Use lifting device or belt for lifting fan motor, if necessary



During the first commissioning of the burner or in case of any revision carried out in the electrical system or motor cables by any reason, direction of the fan rotation must certainly be checked by the authorized technical service.



For products that have not been commissioned or started more than 6 months, before activating the servomotor;

In gas and air dampers, servomotor and air damper connections must be checked to ensure that they are free running in spite of immobility and oil freezing.



BURNER ROOM

Install the burner in a suitable room/floor with minimum external air openings and sufficient to ensure perfect combustion, in compliance with current regulations.

Never obstruct air openings of the burner room, burner fan intake vents or air ducts in order to prevent:

- a. The build up of toxic / explosive gas mixtures in the burner room,
- b. Combustion with insufficient air, resulting in hazardous, anti-economical and polluting operation.

The burner must be always protected from rain, snow and frost to prevent corrosion and paint deformations.

Keep the burner room clean and free of solid volatile substances, which could be sucked into the fan and clog the internal burner or combustion head air ducts.

2. TERMS OF WARRANTY

Main and auxiliary equipment and all components used in Ecostar gas burners are guaranteed for 1 year by TERMO ISI SİST. A.Ş starting from the date of commissioning under the maintenance, adjustment, operating conditions and relevant mechanic, chemical and thermal effects explained herein.



Please note that this warranty is only valid if the device(s) is commissioned and maintained by our authorized services.



Our company reserves the right to make any modifications on the product and all instructions thereof for improvement purposes.

2.1. Out of Warranty Conditions

- Any damage arising out of or in relation to customers' non-compliance to their responsibilities with regards to installation, commissioning, operation and maintenance,
- Any damage arising out of or in relation to commissioning, repairs and maintenance carried out by unauthorized services,
- Any damage that may occur during transportation or storage of the product,
- Not preserving the product in its original packaging until the installation stage,
- Incorrect and poor electrical connections, Failures due to incorrect voltage applications, frequent repetition of voltage fluctuations,
- Any damage that may occur as a result of incorrect fuel usage or, foreign substances in the fuel used or using of the product without any fuel,
- Any damage that may occur due to foreign particles entered into the product during installation and operation,
- Failures due to incorrect device selection,
- Any damage to unit due to natural disasters,
- Devices without any warranty certificates,
- Warranty Certificates without the stamp and signature of the authorized dealer or service,
- Devices with any falsification on the warranty certificate or without an original serial number.
- The risks during transportation of device under the responsibility of customer belong to the customer.
- Presence of misuse faults are indicated in the reports issued by authorized service stations or our authorized agent, dealer, representative or our factory in case of unavailability of authorized service stations.
- Customers may apply consumer protection arbitrator committee with regards to this report and request for an expert report.

3. BURNER'S GENERAL FEATURES

ECOSTAR gas burners are manufactured such that they operate in gas pressure of min. 20 mbar and max. 300 mbar., at 15%...+10% of nominal voltage, between the ambient temperature range of -15°C...+60°C and declared capacity and boiler pressure ranges with Natural Gas and Liquid Petrol Gas.

3.1. Purpose of Use and Work Limits of Burners

- This product works at any load value equivalent to its max. capacity or covered by its capacity range;
 - In hot water and steam boilers,
 - In direct and indirect hot air generators,
 - Industrial appliances operating at temperature below 600 °C,
 - -15 °C...+60 °C ambient temperature range,
 - 1N 230 VAC/3N 380VAC /50 Hz feed voltage (-%15...+%10) values,
 - Max. 95% relative humidity,
 - In well-ventilated open and closed spaces compatible with protection class IP 40.
 - Operation with Natural gas and LPG.



This device must never be operated with open flame!

3.2. Code Key

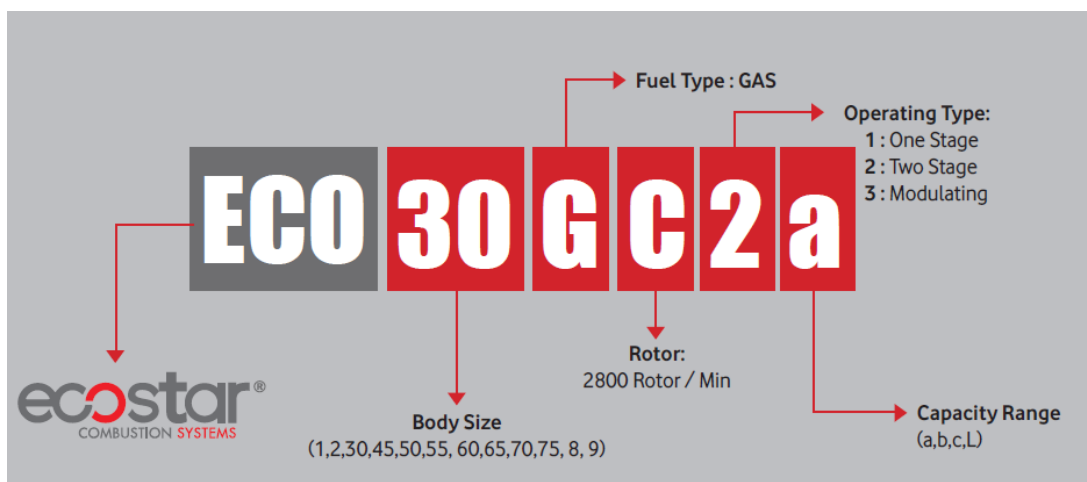

3.3. Burner Components

ECO 1

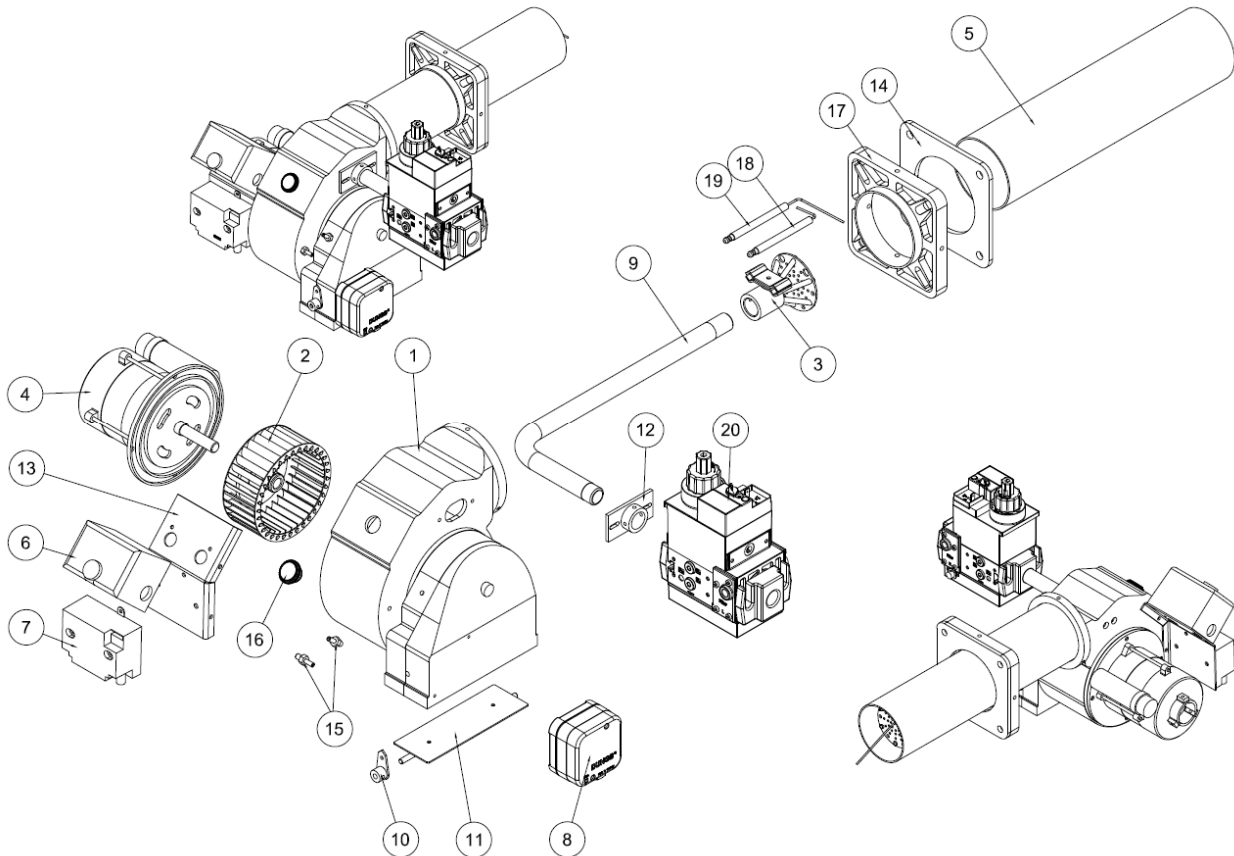

Assembly No	Part Name	Assembly No	Part Name
1	Body Group	11	Air Damper
2	Fan	12	Gas Pipe Connection Flange
3	Combustion Head	13	Transformer-Relay Plate
4	Fan Motor	14	Gasket
5	Flame Tube	15	Pressure Switch Adaptor
6	Control Relay	16	Observation Glass
7	Transformer	17	Boiler Connection Flange
8	Pressure Switch	18	Ignition Electrode
9	Gas Pipe	19	Ionization Electrode
10	Damper Gauge	20	Gas Valve

ECO 2

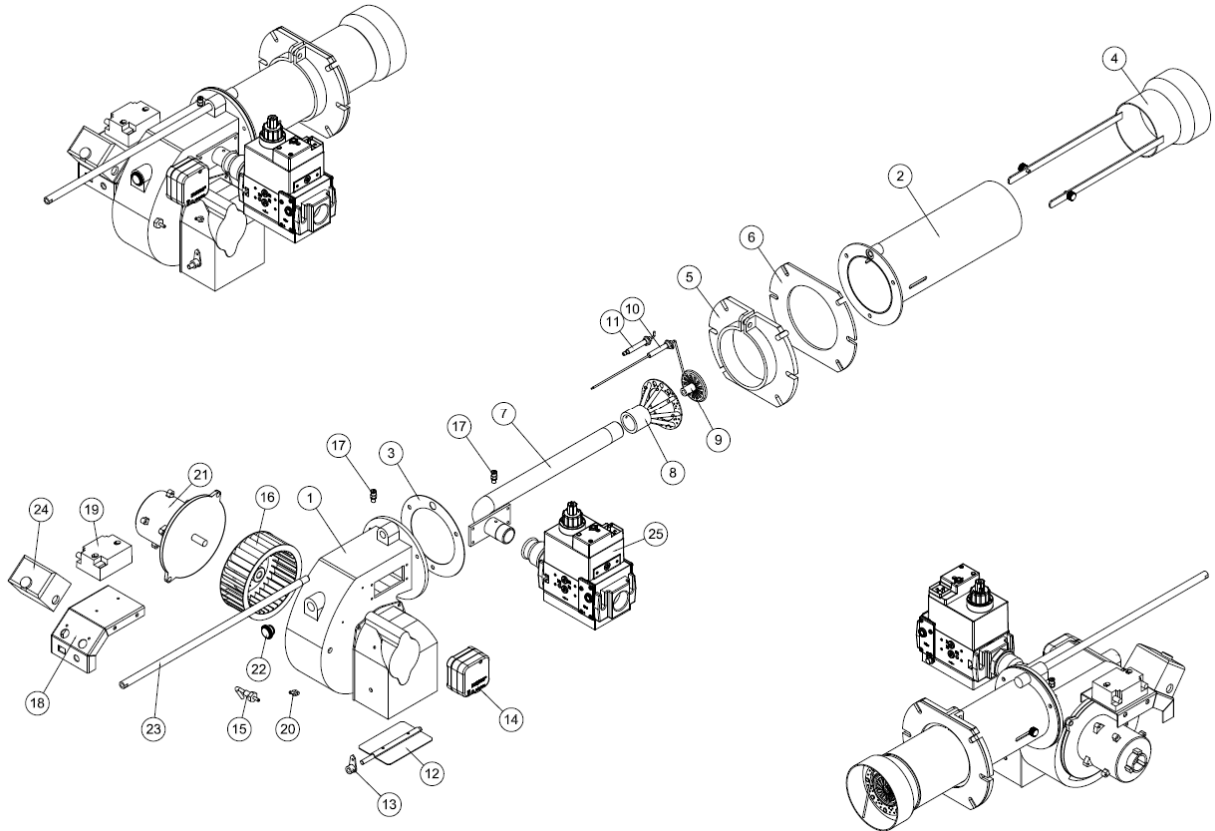

Assembly No	Part Name	Assembly No	Part Name
1	Body Group	14	Pressure Switch
2	Flame Tube	15	Pressure Switch Adaptor
3	Gasket	16	Fan
4	Flame Tube Extension	17	Purger
5	Boiler Connection Flange	18	Relay Mounting Plate
6	Gasket	19	Transformer
7	Gas Intake Pipe	20	Pressure Switch Adaptor
8	Combustion Head	21	Fan Motor
9	Diffuser	22	Observation Glass
10	Ionization Electrode	23	Handling Shaft
11	Ignition Electrode	24	Control Relay
12	Air Damper	25	Gas Valve
13	Damper Gauge		

ECO 30-45

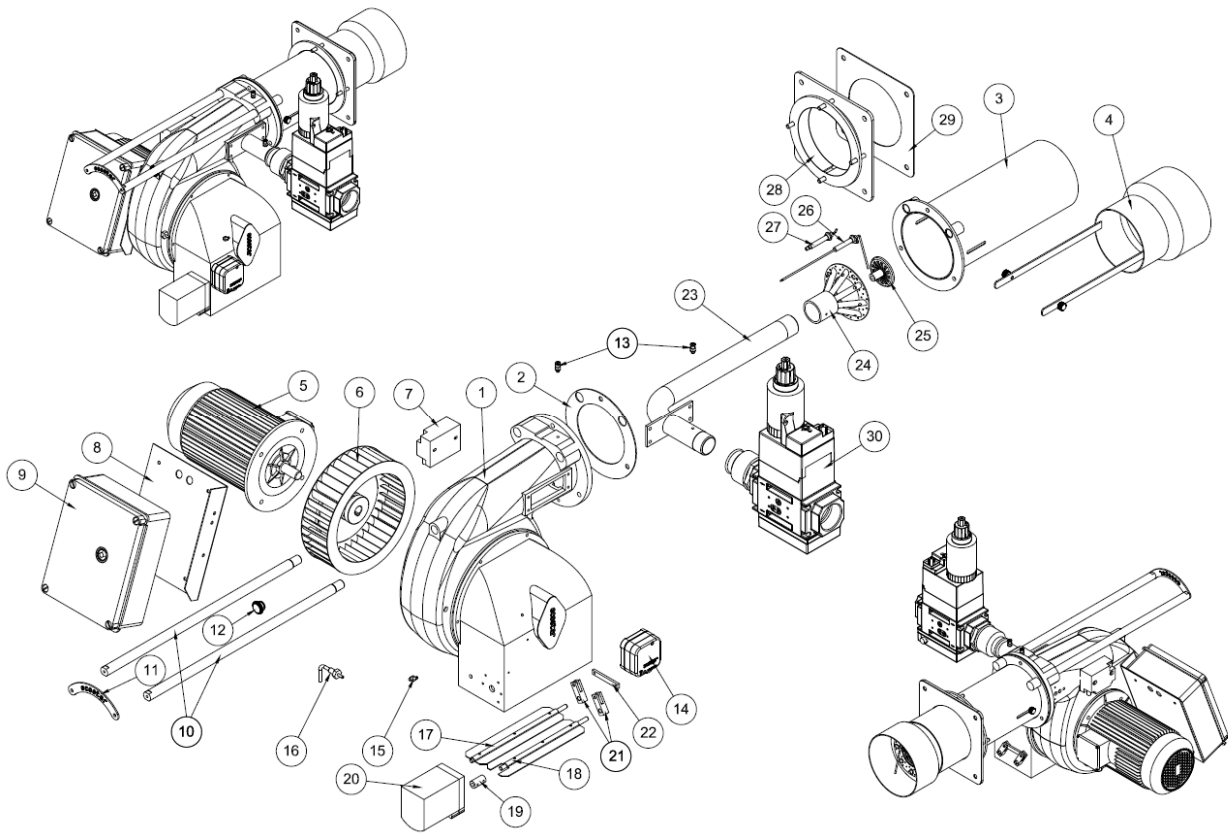

Assembly No	Part Name	Assembly No	Part Name
1	Body Group	16	Pressure Switch Adaptor
2	Gasket	17	Air Damper Long
3	Flame Tube	18	Air Damper Short
4	Flame Tube Extension	19	Servomotor Coupling
5	Fan Motor	20	Servomotor
6	Fan	21	Damper Motion Rod
7	Transformer	22	Air Damper Motion Transfer Rod
8	Electrical Panel Mounting Plate	23	Gas Intake Pipe
9	Electrical Panel	24	Combustion Head
10	Handling Shaft	25	Diffuser
11	Fixing Plate	26	Ionization Electrode
12	Observation Glass	27	Ignition Electrode
13	Purger	28	Boiler Connection Flange
14	Pressure Switch	29	Gasket
15	Pressure Switch Adaptor	30	Gas Valve

4. GAS, FLUE GAS AND HEATING WATER SCHEMA

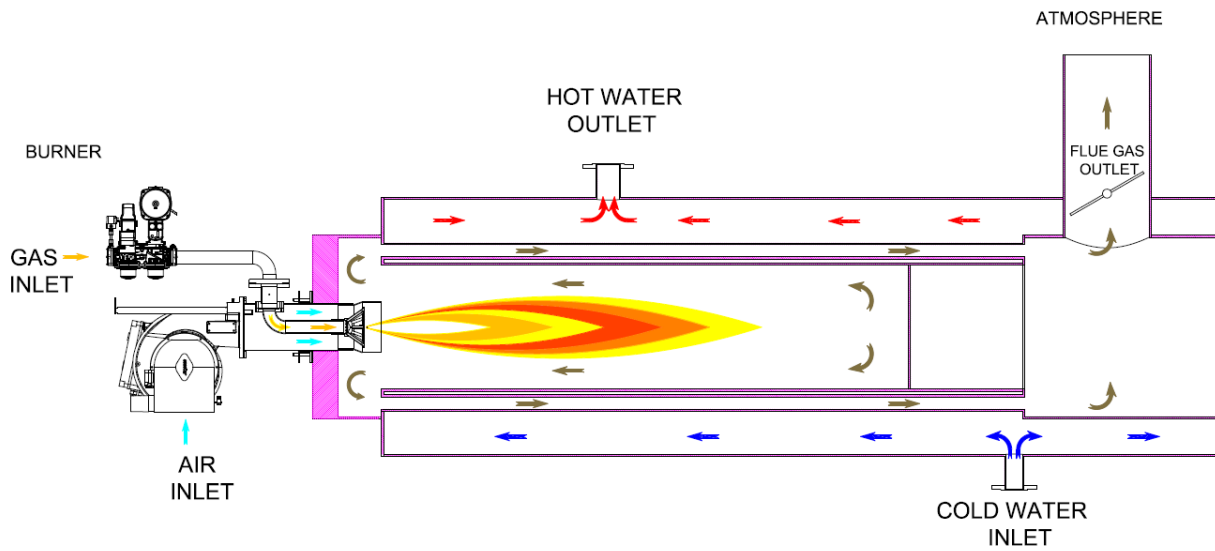

5. TECHNICAL DATA

5.1. Capacity Table

GAS BURNERS CAPACITY TABLE										
BURNER TYPE	CAPACITY		CAPACITY		NATURAL GAS CONSUMPTION		LPG GAS CONSUMPTION		FAN MOTOR POWER	MAIN SUPPLY
	Min. kcal/h	Max. kcal/h	Min. kW	Max. kW	Min. Nm ³ /h	Max. Nm ³ /h	Min. Nm ³ /h	Max. Nm ³ /h	kW	VAC
ONE STAGE GAS BURNERS										
ECO 1 G C 1	8.600	43.000	10	50	1,0	5,2	0,4	1,9	0,11	1N 230
ECO 1 G C 1a	17.200	86.000	20	100	2,1	10,4	0,8	3,8	0,11	1N 230
ECO 2 G C 1	51.600	172.000	60	200	6,3	20,8	2,3	7,6	0,15	1N 230
ECO 2 G C 1a	86.000	299.280	100	348	10,4	36,3	3,8	13,3	0,15	1N 230
TWO STAGE GAS BURNERS										
ECO 2 G C 2	51.600	172.000	60	200	6,3	20,8	2,3	7,6	0,15	1N 230
ECO 2 G C 2 a	86.000	299.280	100	348	10,4	36,3	3,8	13,3	0,15	1N 230
ECO 30 G C 2	163.400	387.000	190	450	19,8	46,9	7,3	17,2	0,37	1N 230
ECO 30 G C 2a	223.600	602.000	260	700	27,1	73,0	9,9	26,8	0,75	3N 380
ECO 45 G C 2	288.100	645.000	335	750	34,9	78,2	12,8	28,7	0,75	3N 380
ECO 45 G C 2/L	288.100	749.920	335	872	34,9	90,9	12,8	33,3	0,75	3N 380
ECO 45 G C 2a	331.100	928.800	385	1.080	40,1	112,6	14,7	41,3	1,10	3N 380
ECO 45 G C 2b	331.100	1.075.000	385	1.250	40,1	130,3	14,7	47,8	1,50	3N 380
MODULATING GAS BURNERS										
ECO 2 G C 3	51.600	172.000	60	200	6,3	20,8	2,3	7,6	0,15	1N 230
ECO 2 G C 3 a	86.000	299.280	100	348	10,4	36,3	3,8	13,3	0,15	1N 230
ECO 30 G C 3	163.400	387.000	190	450	19,8	46,9	7,3	17,2	0,37	1N 230
ECO 30 G C 3a	223.600	602.000	260	700	27,1	73,0	9,9	26,8	0,75	3N 380
ECO 45 G C 3	288.100	645.000	335	750	34,9	78,2	12,8	28,7	0,75	3N 380
ECO 45 G C 3/L	288.100	749.920	335	872	34,9	90,9	12,8	33,3	0,75	3N 380
ECO 45 G C 3a	331.100	928.800	385	1.080	40,1	112,6	14,7	41,3	1,10	3N 380
ECO 45 G C 3b	331.100	1.075.000	385	1.250	40,1	130,3	14,7	47,8	1,50	3N 380

H_u Natural Gas =8250 kcal/Nm³

H_u LPG=22500 kcal/Nm³

5.2. Back Pressure-Capacity Diagrams

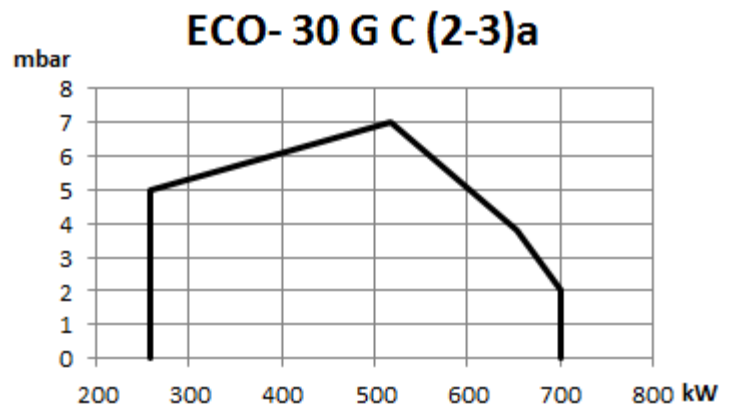
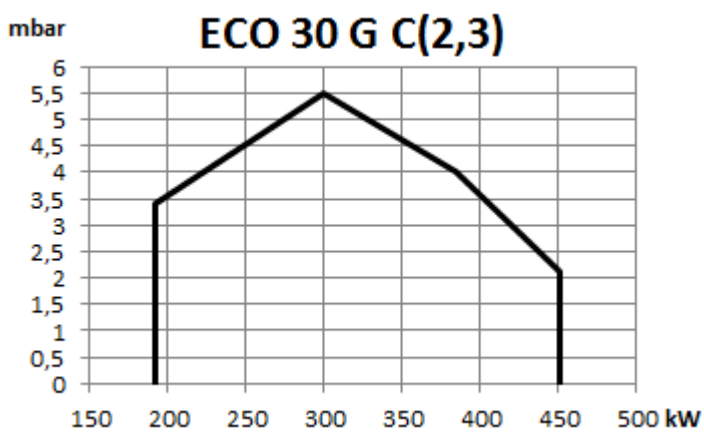
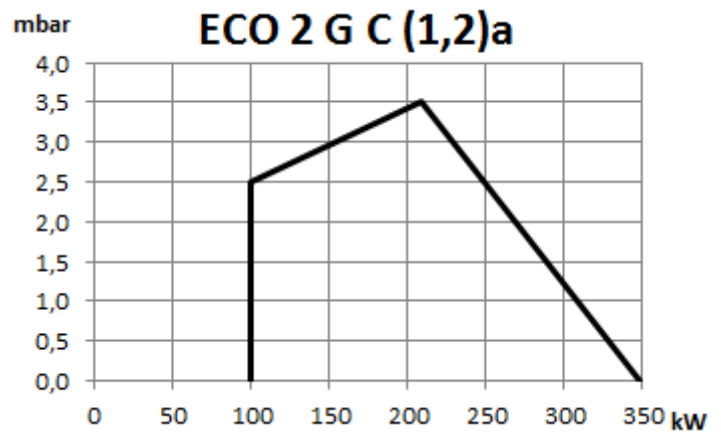
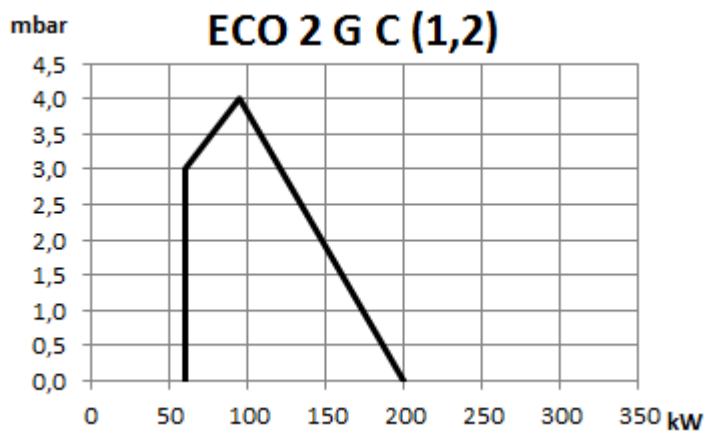
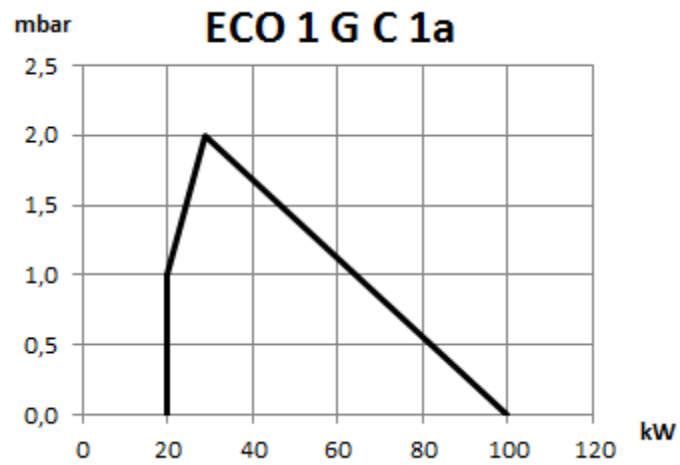
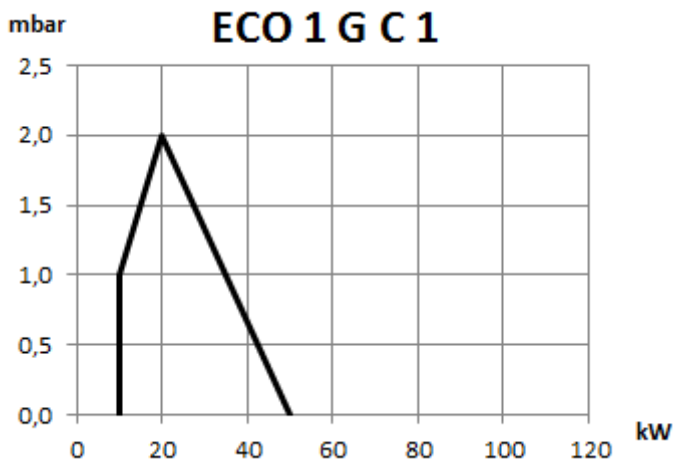

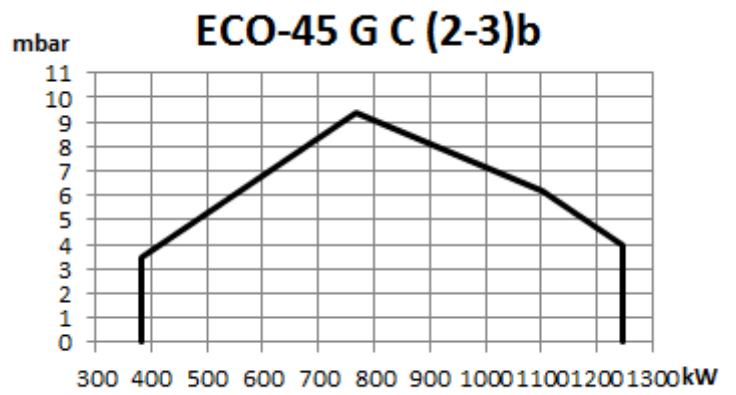
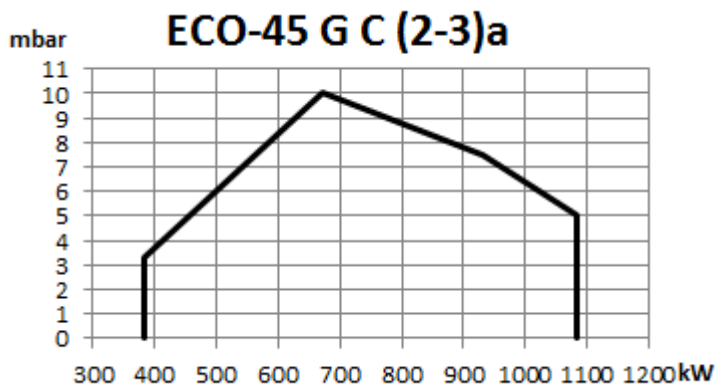
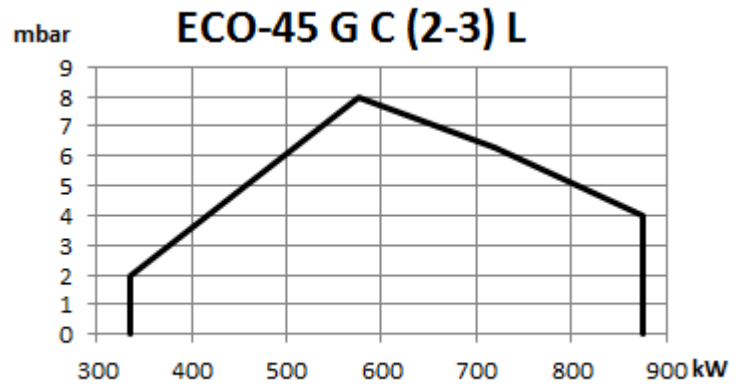
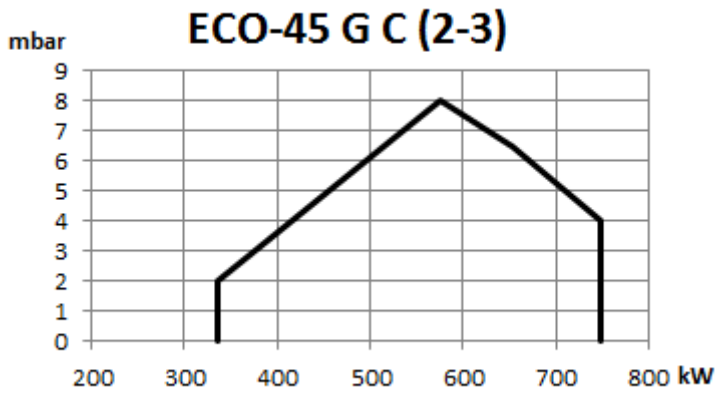

5.3. Burner Dimensions

ECO 1

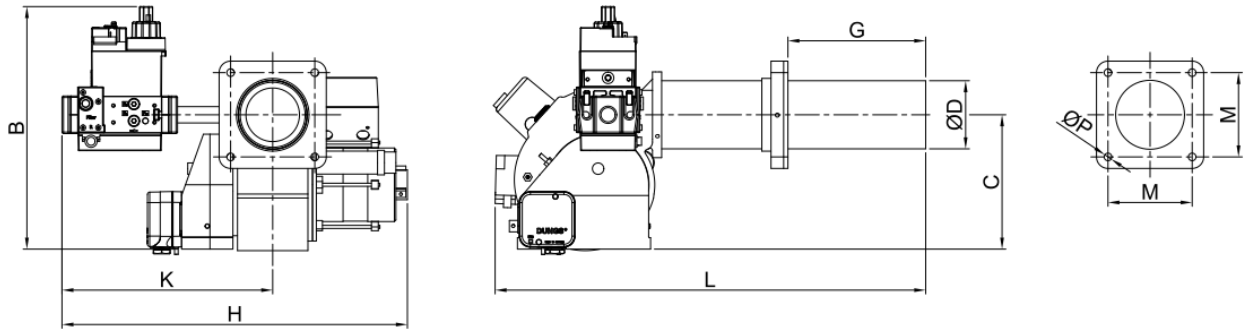

ECO 2 ECO 30 ECO 45

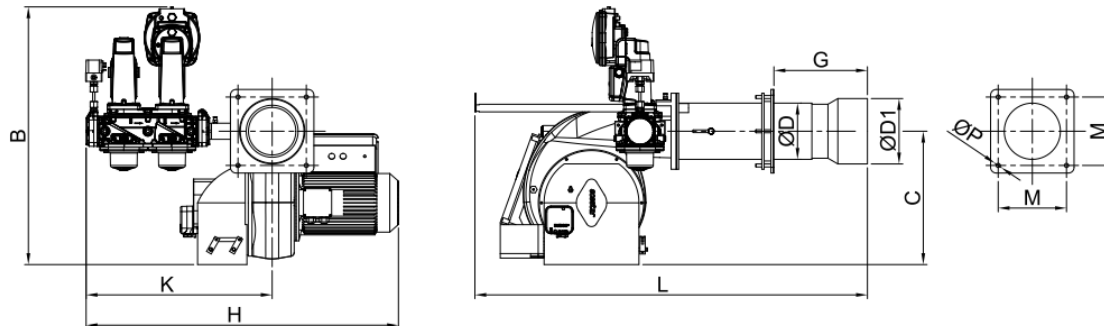

	L	Gmin	Gmax	H	K	B	C	ØP	M	ØD	ØD1
ECO 1 G	565	50	310	455	275	320	175	10	110	89	-
ECO 2 G	960	110	320	510	335	400	225	10	142	120	139
ECO 30 G	960	130	320	730	400	570	305	10	142	131	153
ECO 45 G	1030	150	360	830	490	680	350	11	180	148	172

5.4. Gas Hood Pressure Loss Diagram



Gas hood pressure loss measurements are conducted in atmospheric pressure. Consider the below data while conducting measurement in counter pressure boilers.

P_m : Gas hood pressure while burner is connected to the boiler and working

P_F : Combustion chamber pressure

P_{Br} : Burner net gas hood pressure

$$P_{Br} = P_m - P_F$$

ECO 1

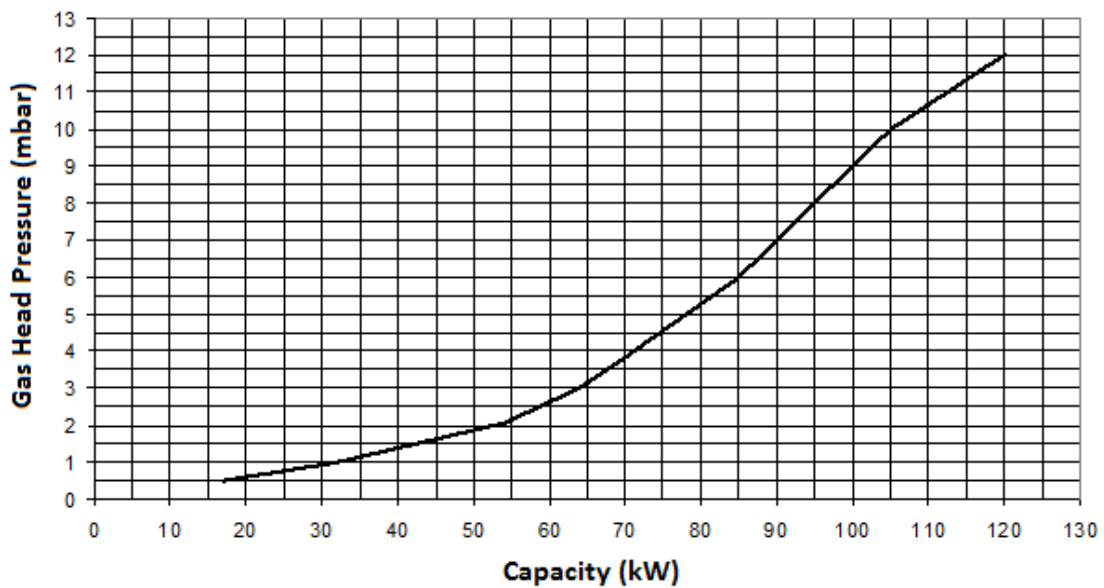

ECO 2

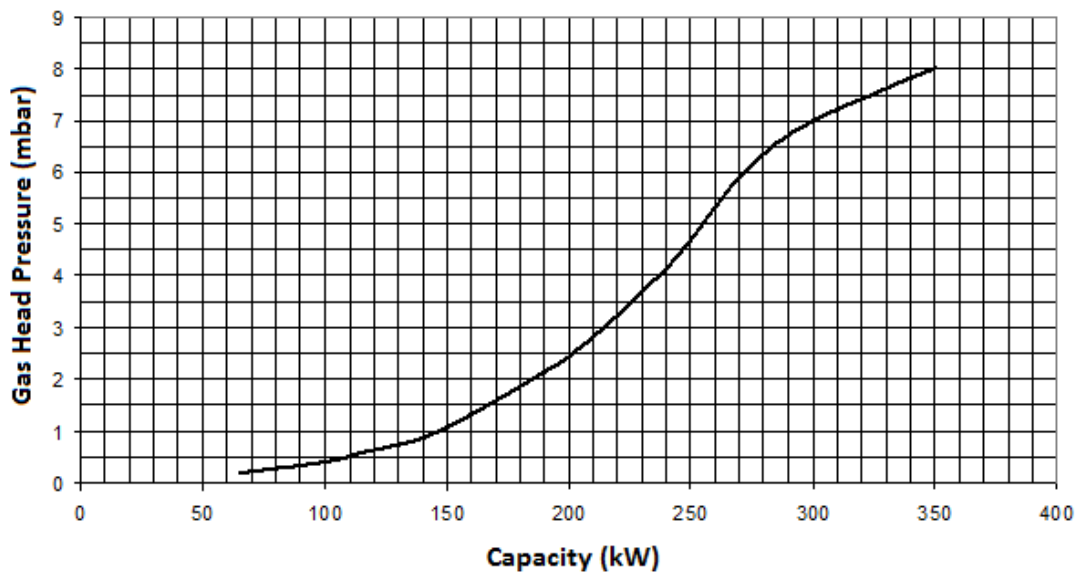

ECO 30

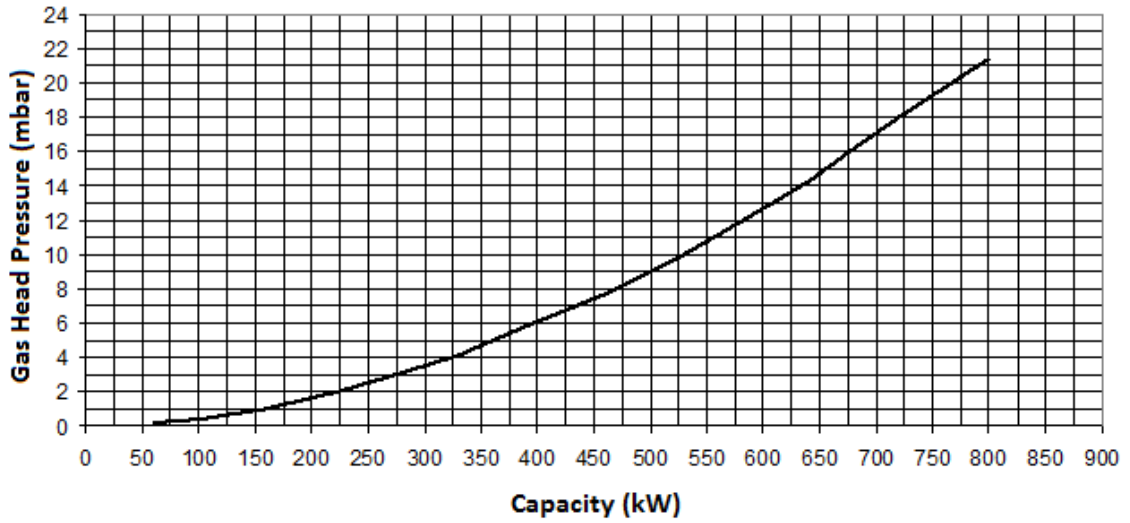

ECO 45

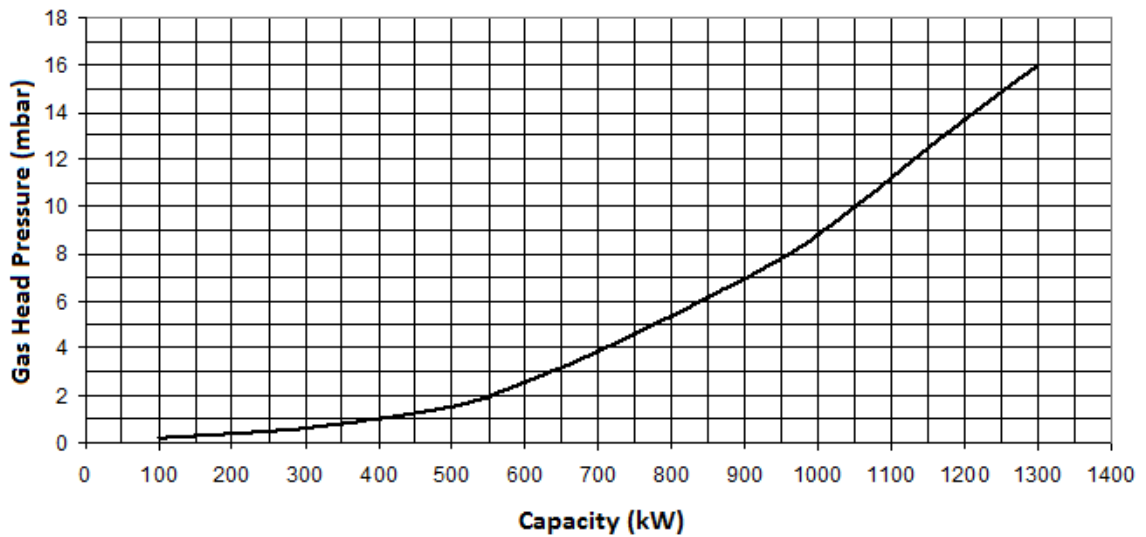

5.5. Flame Length and Diameter

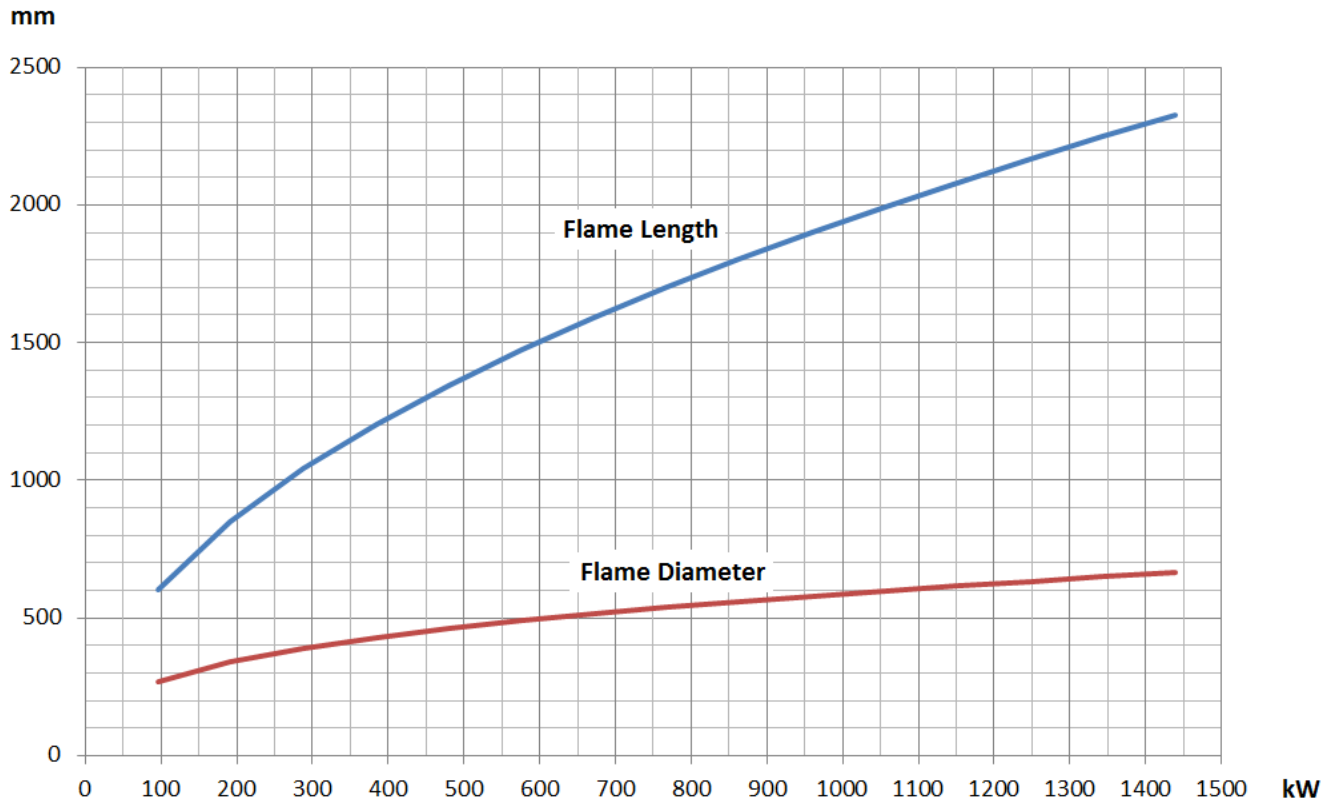

5.6. Noise Level

Product operates within the range of 75 decibels max. and 85 decibels.

6. BURNER HANDLING INFORMATION

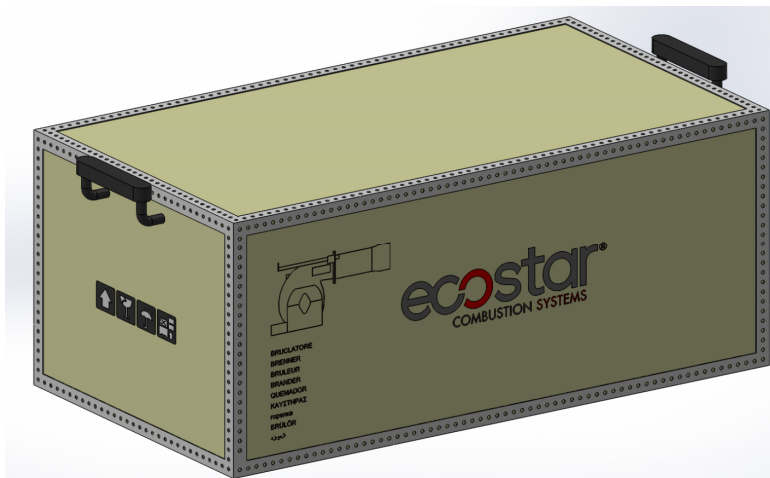

- Lift the product by holding the handles as seen in the picture.
- Prevent strong impacts on top of the product and vibration while handling the product.
- Do not leave the product in wet environment.



Dimensions of the box used for handling

Burner	L x W x H (cm)	Weight (kg)
ECO 1 GC1(300 mbar)	65 X 43 X 37	18
ECO 1 GC1a(300 mbar)	65 X 43 X 37	18
ECO 2 GC1(300 mbar)	65 X 43 X 37	22
ECO 2 GC1(21 mbar)	65 X 43 X 37	26
ECO 2 GC1a(300 mbar)	65 X 43 X 37	22
ECO 2 GC1a(21 mbar)	65 X 43 X 37	26
ECO 2 GC2(300 mbar)	65 X 43 X 37	24
ECO 2 GC2(21 mbar)	65 X 43 X 37	24
ECO 2 GC2a(21 mbar)	65 X 43 X 37	26
ECO 2 GC2a(300 mbar)	65 X 43 X 37	24
ECO 2 GC3(300 mbar)	65 X 43 X 37	26
ECO 2 GC3a(300 mbar)	65 X 43 X 37	26
ECO 30 GC2(300 mbar)	80 X 54 X 40	40
ECO 30 GC2(21 mbar)	80 X 54 X 40	40
ECO 30 GC2a(300 mbar)	80 X 54 X 40	46
ECO 30 GC2a(21 mbar)	80 X 54 X 40	50
ECO 30 GC3(300 mbar)	80 X 54 X 40	42
ECO 30 GC3(21 mbar)	80 X 54 X 40	42
ECO 30 GC3a(300 mbar)	80 X 54 X 40	48
ECO 30 GC3a(21 mbar)	81 X 54 X 40	44
ECO 45 GC2(300 mbar)	97 X 56 X 45	52
ECO 45 GC2(21 mbar)	97 X 54 X 40	56
ECO 45 GC2a(300 mbar)	97 X 54 X 45	56
ECO 45 GC2a(21 mbar)	97 X 54 X 45	60
ECO 45 GC2b(300 mbar)	97 X 54 X 45	62
ECO 45 GC2L(300 mbar)	97 X 56 X 45	52
ECO 45 GC2L(21 mbar)	97 X 54 X 40	56
ECO 45 GC3(21 mbar)	97 X 54 X 45	58
ECO 45 GC3a(300 mbar)	97 X 54 X 45	60
ECO 45 GC3b(300 mbar)	97 X 54 X 45	64
ECO 45 GC3L(300 mbar)	97 X 54 X 45	54
ECO 45 GC3L(21 mbar)	97 X 54 X 45	58

7. INSTALLATION

7.1. Burner Installation Picture

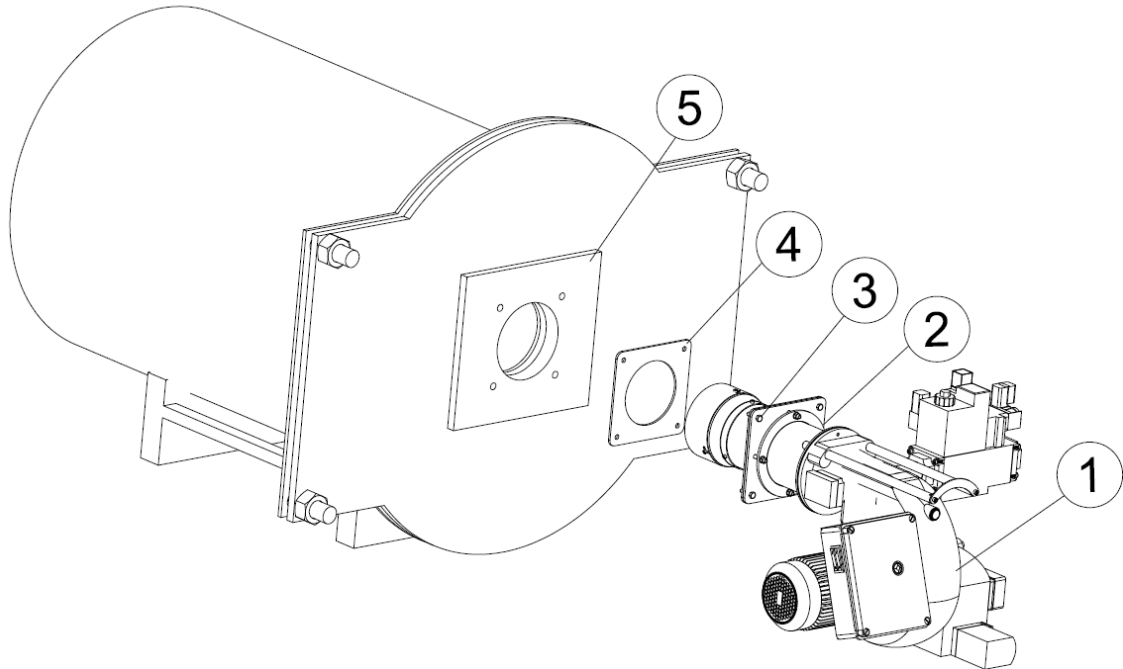

- 1- Burner
- 2- Burner connection flange
- 3- Drift Bolts
- 4- Gasket
- 5- Boiler flange



You must definitely ensure sealing between boiler and burner!



Device must be shipped in original packaging!



Do not lift the device holding from servomotor, gas valve, impulse pipes or pressure switch during installation!



Clean the inside of fuel line thoroughly before installing the burner to the fuel line. Any damage that may occur due to solid objects and metal particles from the fuel line shall not be covered by our company.

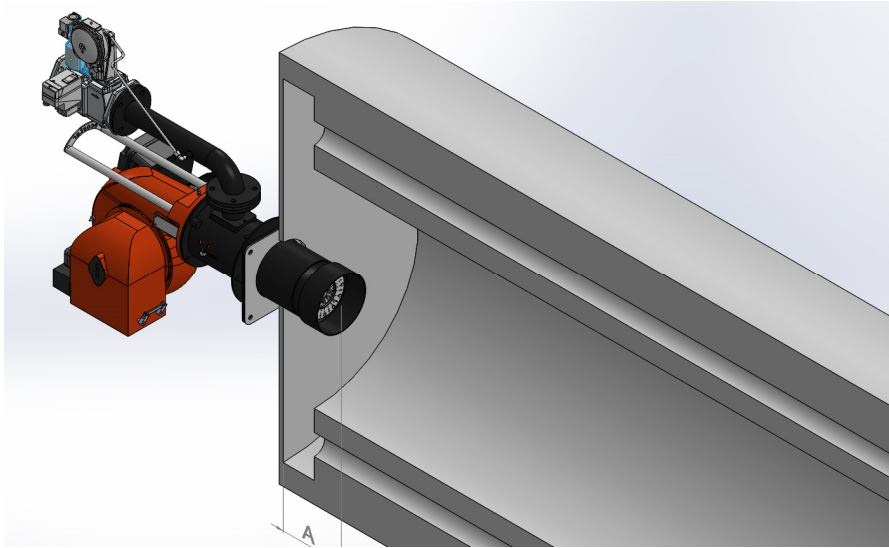

While installing the burner in reverse flame front mirror boilers, flame tube tip must be adjusted such that it gets inside by 50 mm-100 mm from flue pipes ($50\text{mm} \leq A \leq 100\text{mm}$). Otherwise flue gas temperature will rise and fuel consumption will increase.

8. COMMISSIONING

8.1. Before Commissioning

8.1.1. Ignition and Ionizasyon System

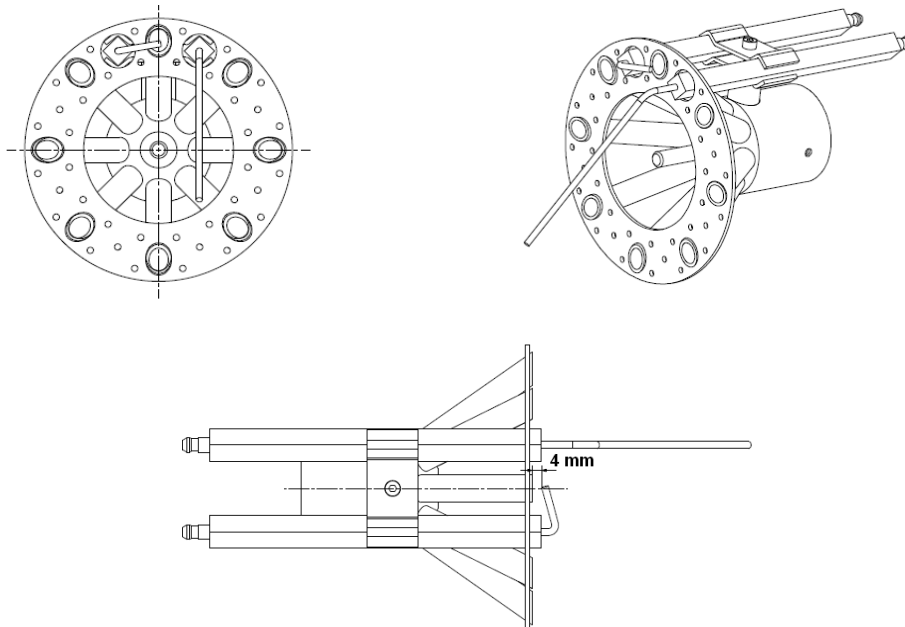

Electrical Connection

Perform electrical connections according to the diagram provided with the burner. Follow general security rules during installation of electric wiring and making connections. Connect the earthing terminal in electric panel to the earthing installation.

8.2. General Controls



Make sure to perform the following controls before commissioning the burner.

- Are the electrical connections correct?
- Is there electricity current?
- Is there gas?
- Has the heating system been filled with water?
- Is the thermostat set at the required temperature?
- Has the boiler explosion lid been controlled?
- Is there sufficient air in boiler room (ventilation section $\text{cm}^2 = \text{boiler capacity kW} \times 7$)
- Has the boiler been installed correctly? Has the boiler cover been closed properly?
- Has the air of the gas line been removed? Has a sealing test been made?

Operation of one-stage burner

- Open the main gas valve, check the gas pressure from the manometer at the valve. (max.300 mbar)
- Check the boiler thermostat or pressure switch settings.
- Bring the operating switch on the burner panel to position 1.
- Burner fan motor will be activated.
- Ignition will take place at the end of pre-purge process.
- 3 sec. later, the gas valve will be opened and combustion will occur.
- Flame control system (ionization) will start flame control.
- After the boiler water heated up or the boiler pressure has risen, the burner will turn off.

Operation of two-stage burner

- Open the main gas valve, check the gas pressure from the manometer at the valve. (max.300 mbar)
- Check the boiler thermostat or pressure switch settings.
- Bring the operating switch on the burner panel to position 2.
- Burner fan motor will be activated.
- Ignition will take place at the end of pre-purge process.
- 3 sec. later, the gas valve will be opened and combustion will occur.
- Flame control system (ionization) will start flame control.
- Burner will switch to the second stage (max. capacity) according to the heat requirement.
- After the boiler water heated up or the boiler pressure has risen, the burner will turn off.

Operation of a modulating burner

- Open the main gas valve; check max 300 mbar gas pressure from the manometer.
- Open operating switch on the burner panel.
- Switch on the modulating control switch.
- Switch automatic-hand switch to automatic.
- Check the temperature and pressure set values from the modulating control unit.
- Ignition will take place at the end of pre-purge process.
- 3 sec. later, the gas valve will be opened and combustion will occur.
- Flame control system (ionization) will start flame control.
- In modulating burner, the burner goes into max. capacity according to the signal from the modulating control unit.
- When the boiler water temperature or steam pressure increase, the modulating control unit will cause burner to run with min. capacity.
- If the boiler water temperature or steam pressure increases despite the operation of burner with min. capacity, the modulating control unit will stop the burner.

8.3. Combustion Adjustment

8.3.1. Gas Adjustment

Follow the instructions of the valve manufacturer during installation, dismantling and adjustment of the gas valve

8.3.1.1. VGD 20 4011 - 5011 Series Gas Valve

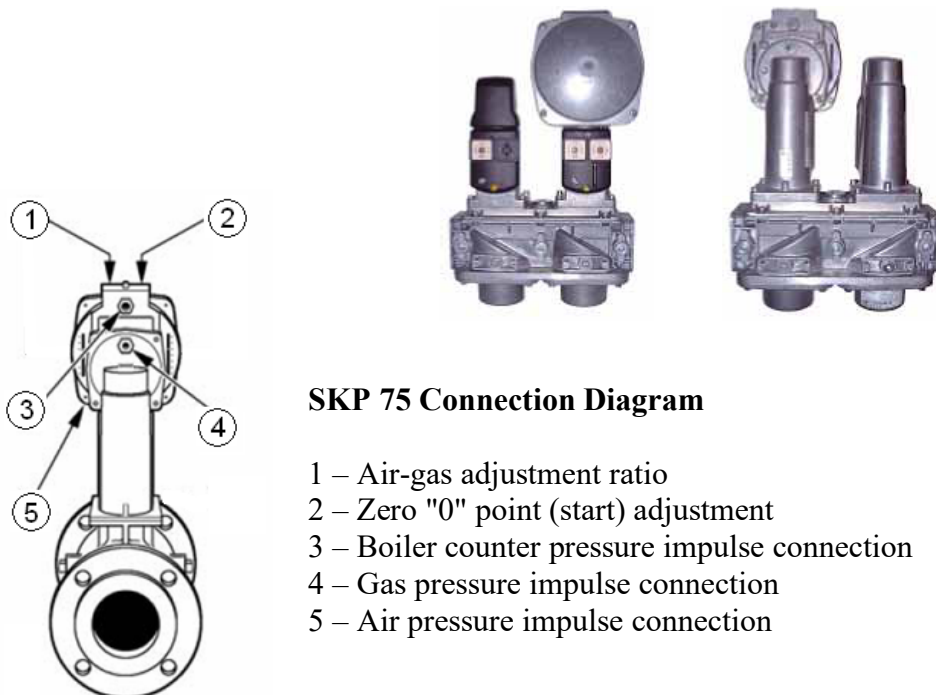

SKP 75 Connection Diagram

- 1 – Air-gas adjustment ratio
- 2 – Zero "0" point (start) adjustment
- 3 – Boiler counter pressure impulse connection
- 4 – Gas pressure impulse connection
- 5 – Air pressure impulse connection

8.3.1.2. MB DLE Series Monoblock Gas Valve

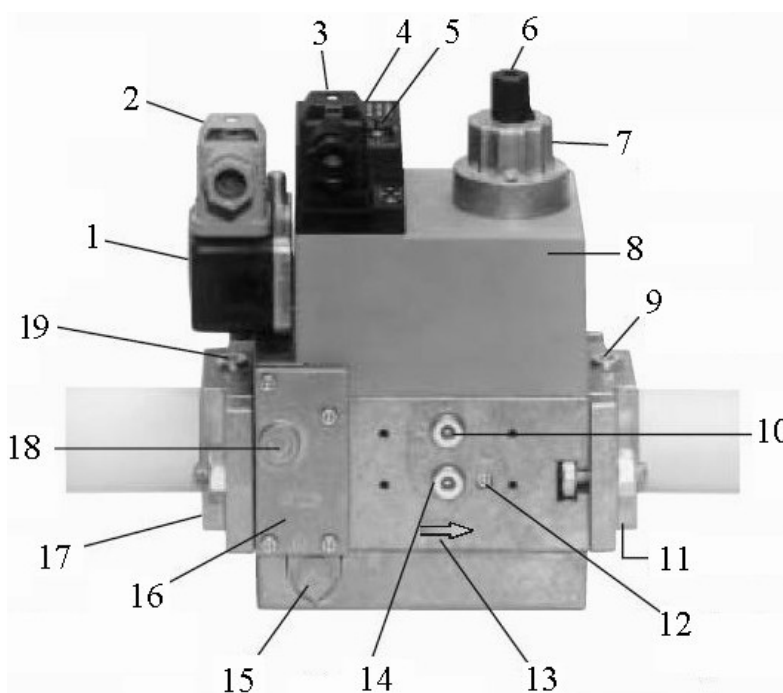

- 1- Pressure switch
- 2- Pressure switch electrical connection
- 3- Electrical connection of the valve
- 4- Operation gauge
- 5- The sealing ring
- 6- Set cover
- 7- Hydraulic disk brakes or settings
- 8- Coil
- 9- Measuring element connection (1/8)
- 10- Measuring element connection (1/8)
- 11- Output flange
- 12- Measuring element connection (1/8)
- 13- Gas flow way
- 14- Measuring element connection (1/8)
- 15- The vent plug
- 16- Filter chamber cover
- 17- Inlet flange
- 18- Measuring element connection (1/8)
- 19- Measuring element connection (1/8)

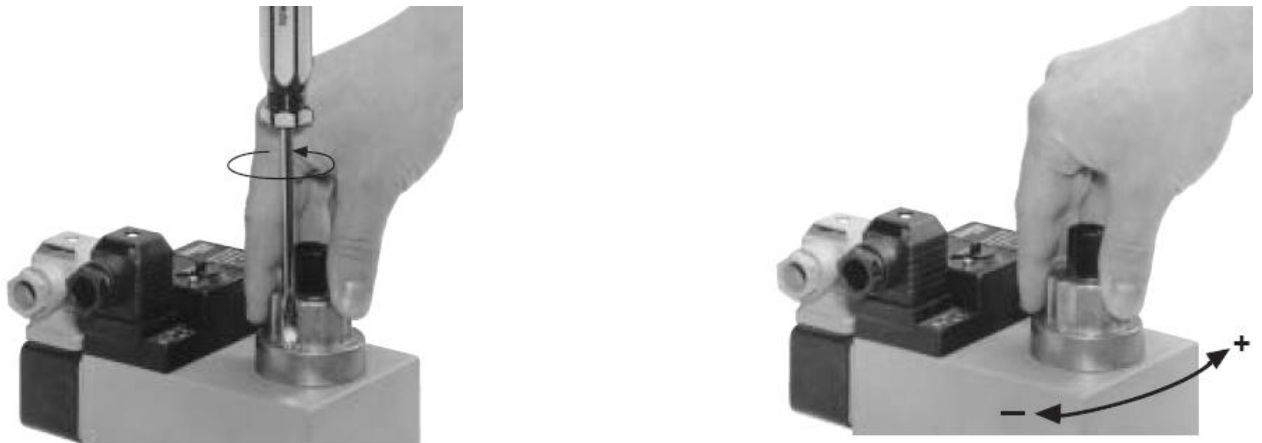

- Consider the below torque values for bolts tightened on the valve.
- Tighten flange bolts according to cross ordering and use proper tools.
- Sealing and function check must be performed if the valve is dismantled and re-installed over the line due to any reason.
- Before dismantling the valve from the line, you can perform filter replacement according to the below order.
 - o Cut off the gas flow (turn off the ball valve)
 - o Remove the 4 bolts (1,2,3,4) on the cover seen in the picture and take out the cover (5).
 - o Take the filter cartridge (6) out of its socket and replace with a new one
 - o Close the cover and tighten the bolts. In frequently performed filter replacement operations, use M4x14 bolt instead of self-tapping bolts used for fixing the cover.
 - o Perform sealing and function control

Max. torque values;

M 4	M 5	M 6	M 8	G 1/8	G 1/4	G 1/2	G 3/4
2,5 Nm	5 Nm	7 Nm	15 Nm	5 Nm	7 Nm	10 Nm	15 Nm

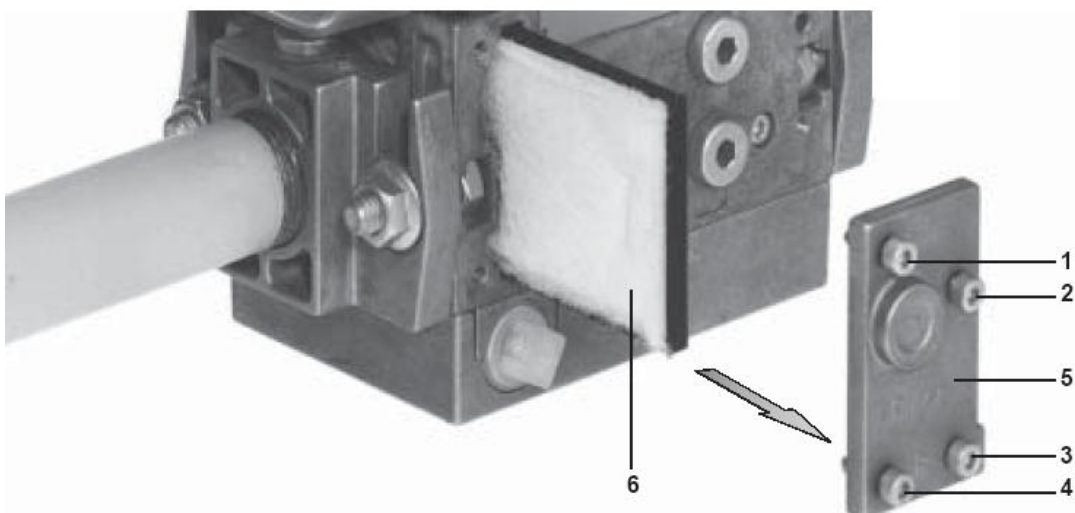

8.3.1.3. MB ZRD(LE) 405 – 412 Series Gas Valve

GasMultiBloc[®]
Combined regulator and
safety shut-off valves
Two-stage function

MB-ZRD(LE) 405 - 412 B01

DUNGS[®]
Combustion Controls

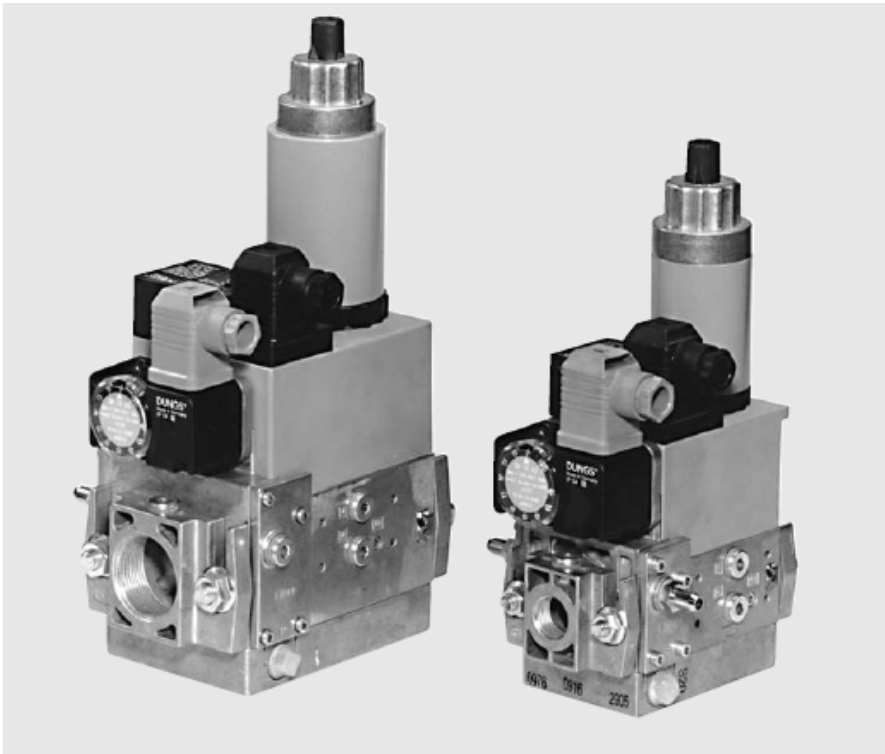

Technical description

The DUNGS GasMultiBloc[®] integrates filter, regulator, valves and pressure switches in one compact fitting.

- Dirt trap: microfilter
- One regulator and two main valves: B01
- One one-stage valve and one two-stage valve
- One valve is fast opening, one valve is slow or fast opening
- Solenoid valves up to 360 mbar (36 kPa) as per DIN EN 161 Class A Group 2
- Sensitive setting of output pressure by proportional regulator as per DIN EN 88 Class A Group 2
- High flow rates with low pressure drop
- DC solenoid drive interference degree N
- Main volume restrictor and partial volume restrictor at valve V2
- Hydraulic opening delay
- Flange connections with pipe threads as per ISO 7/1
- Simple mounting, compact, light-weight

The modular system permits individual solutions by using external ignition gas tap in connection with separately controlled valves, by adding a valve proving system, mini/maxi pressure switches, pressure limiters, limit switch and closing stroke limiter at valve V2, regulator blocking for liquid gas applications.

Application

The modular system permits individual solutions in gas safety and regulator engineering. Suitable for gases of families 1, 2, 3 and other neutral gaseous media.

Approvals

EC type test approval as per EC Gas Appliance Directive:
MB-ZR...405-412 B01 CE-0085 AP 3156
EC type test approval as per EC Pressure Equipment Directive:
MB-ZR...405-412 B01 CE0036
Approvals in other important gas consuming countries.

8.4. Air Pressure Switch Adjustment

While the burner is working without any problem, the air pressure switch is adjusted to desired minimum pressure as follows.

- Unscrew the screw of the transparent cover and remove the cover.
- Turn the adjustment wheel in the direction to increase the pressure, note the pressure value at which the burner is failed.
- Set the pressure switch to a value 1 mbar lower than the pressure value at which the burner failed and close the pressure switch lid.
- It is recommended that this adjustment is carried out when the burner is at minimum load.



8.5. Servomotor Adjustment

The amount of air is adjusted by means of the servomotor. The servomotor adjustment at two-stage and modulating burners is made by the cams on the servomotor.

➤ SQN70

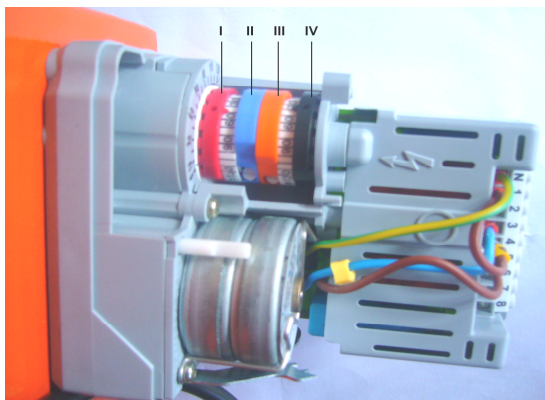

At Two-Stage Burners;

- I. Red Cam: Adjusts 2nd level max. air.
- II. Blue Cam: Resets the clamp.
- III. Orange Cam: Adjusts 1st level min. air.
- IV. Black Cam: Adjusts 2nd level valve opening degree.

At Modulating Burners;

- I. Red Cam: Performance max. air adjustment.
- II. Blue Cam: Resets the clamp.
- III. Orange Cam: Performs min. air adjustment.
- IV. Black Cam: Not used.



Do not open servomotor. Do not interfere with. It may damage servomotor or change burner settings.

8.6. Emission Measurement

In emission measurements, the following values are accepted as reference according to TS EN 676 +A2 standard.

- CO < 100 mg/ kWh
- %3 ≤ O₂ ≤ %5
- NO_x < 170 mg/ kWh
- Excess air ratio 1,2 ≤ λ ≤ 1,3



It is important for the boiler to be sealed in order to avoid incorrect measurements during emission measurements.



Boiler temperature must be between 40 C° and 80 C° while making emission measurement in hot water boilers.

8.7. Capacity Adjustment

Exemplary Application:

Suppose the required burner capacity is (C) 500 kW.

H_u = 8250 kcal/m³ (lower heating value)

P = 860 kcal/kW (Value of 1 kW in kcal)

Q = C x P

Q = 500x860 = 430000 kcal

V = Q / H_u

V = 430000/8250 = 52,12 m³/h

Set the required gas flow rate over the valve and check this value on the gas counter. Should there be no gas flowmeter in the system, set the burner by using the gas tip lost pressure diagram given at page 15-16.



In order to ensure the emission values set the air klappe in each gas flow increase.

8.8. Program Relay

LME 22



- Yellow led on: Indicates that the burner is making pre-purge.
- Yellow led flashing: Indicates that the burner is igniting.
- Green led flashing: Indicates poor combustion.
- Red led on: Indicates burner malfunction.



Press and hold the light button for 2 sec. to reset the program relay.

8.9. Function Controls and Adjustments

- **Operation testing:** If the burner switch is turned on and safety circuit is complete (gas pressure switch, thermostat, water level gauge, lower pressure gas pressure switch, upper pressure gas pressure switch, gas leakage control device), turn on the ball valve, burner will start working and turn off the gas valve. Program operation of the relay must be normal until ignition time. During opening of the magnetic valve, gas pressure will drop down and the lower pressure switch will stop the burner for safety.
- When the ball valve is opened again, gas pressure will increase and lower pressure switch will trip in from safety position and the burner will automatically start operating.
- Disconnect the ionization circuit or remove the photocell when the burner is operating: Burner will give a fault after burning up.
- Increase the value of the air pressure thermostat: Burner starts operating, however it should give a fault due to the insufficiency of air pressure.



Magnetic valves must not be energized during pre-purge. Check if valves are in closed position!

8.10. Final Checks

- Switch of all purges after completion of all necessary measurements.
- Start and stop the burner at least 3 times to check the operation of the program.
- Make sure that all safety circuits on the burner and boiler operate properly before leaving the installation site.



If the value measure from PL point is below 0.5 bar, set the impulse pipe as follows.

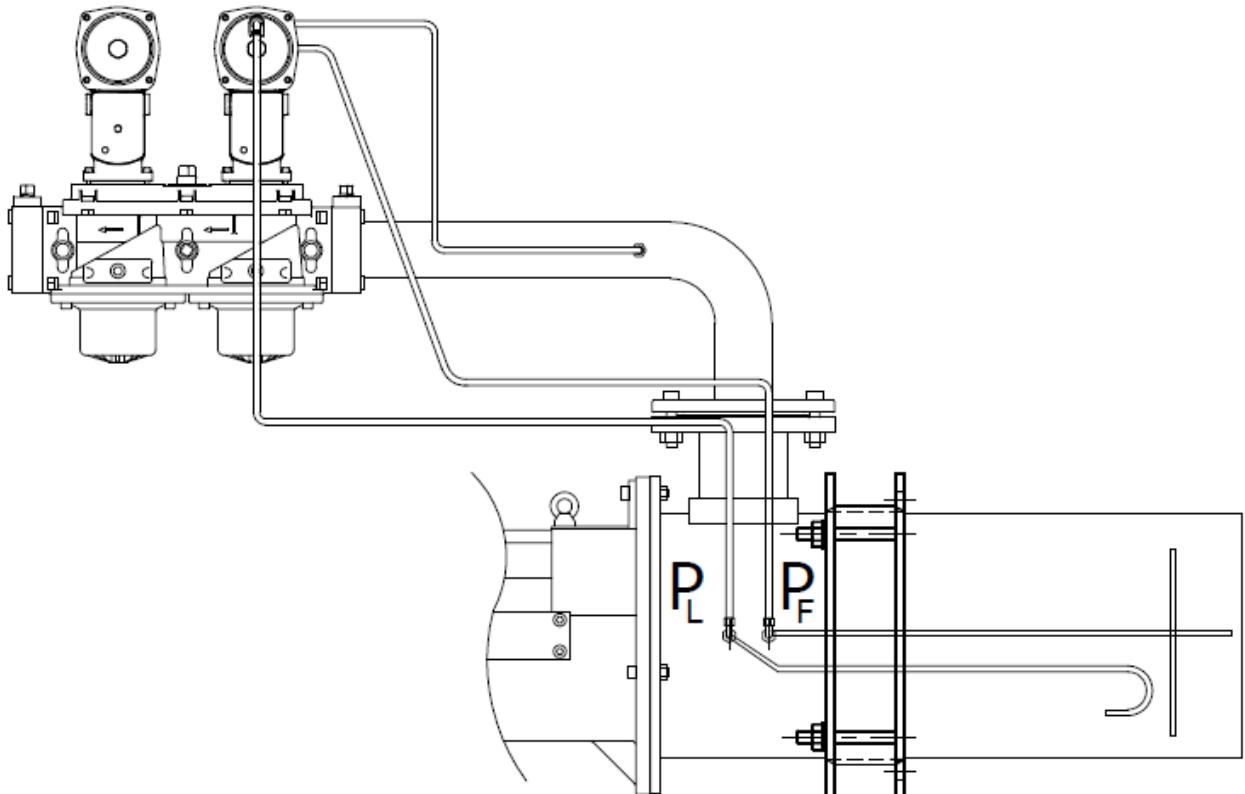
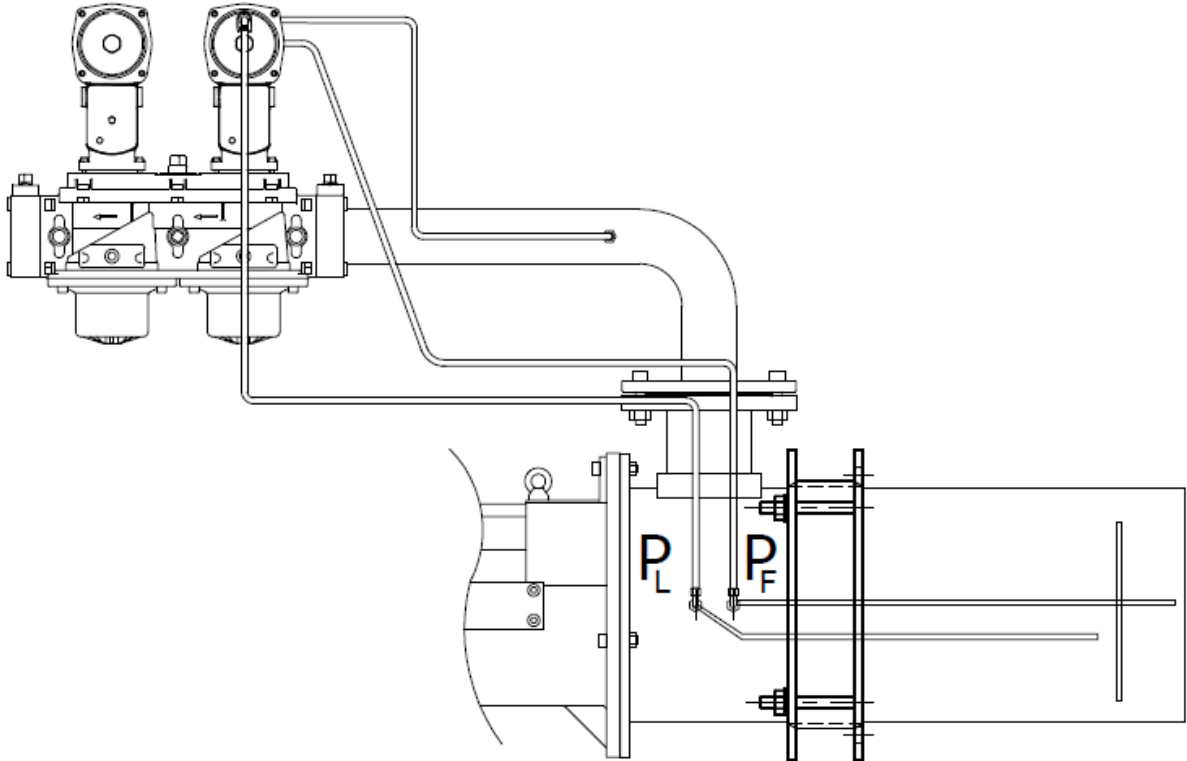



If the flame tube of the burner is longer than standard (standard flame tube length of the burner), please do not forget to support burner body during maintenance and installation/commissioning.

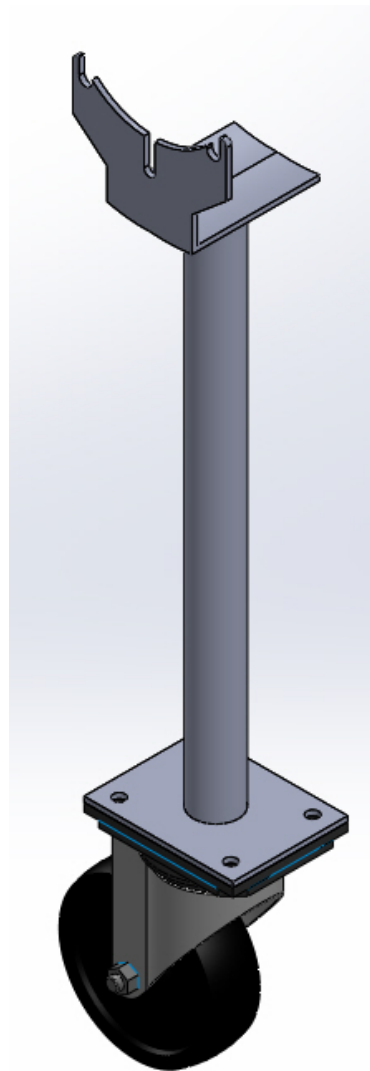
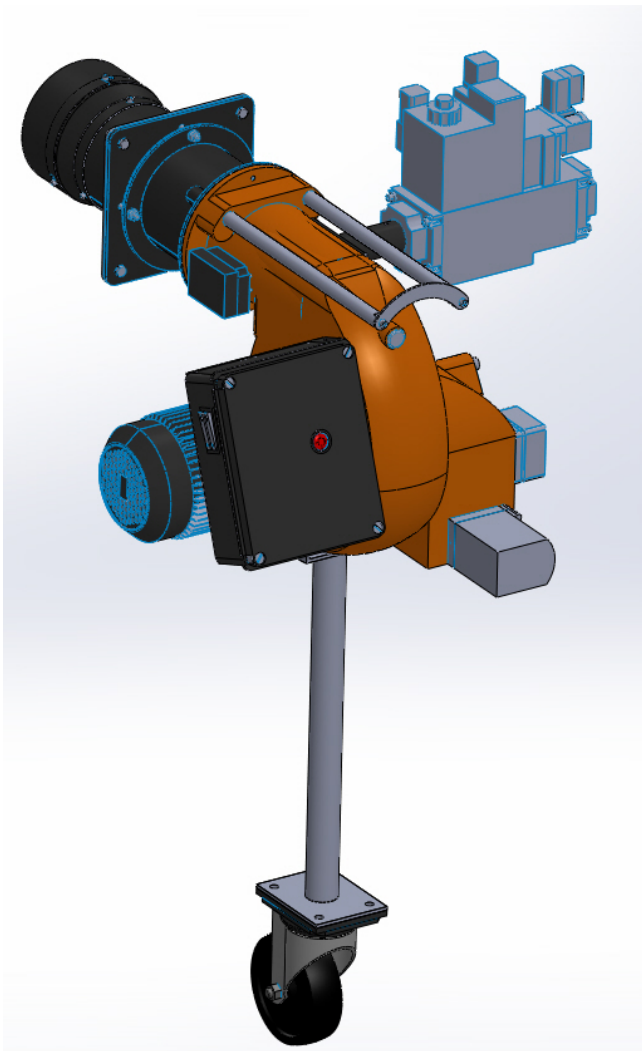

8.11. Gas Pass Equipment Required in Gas Line

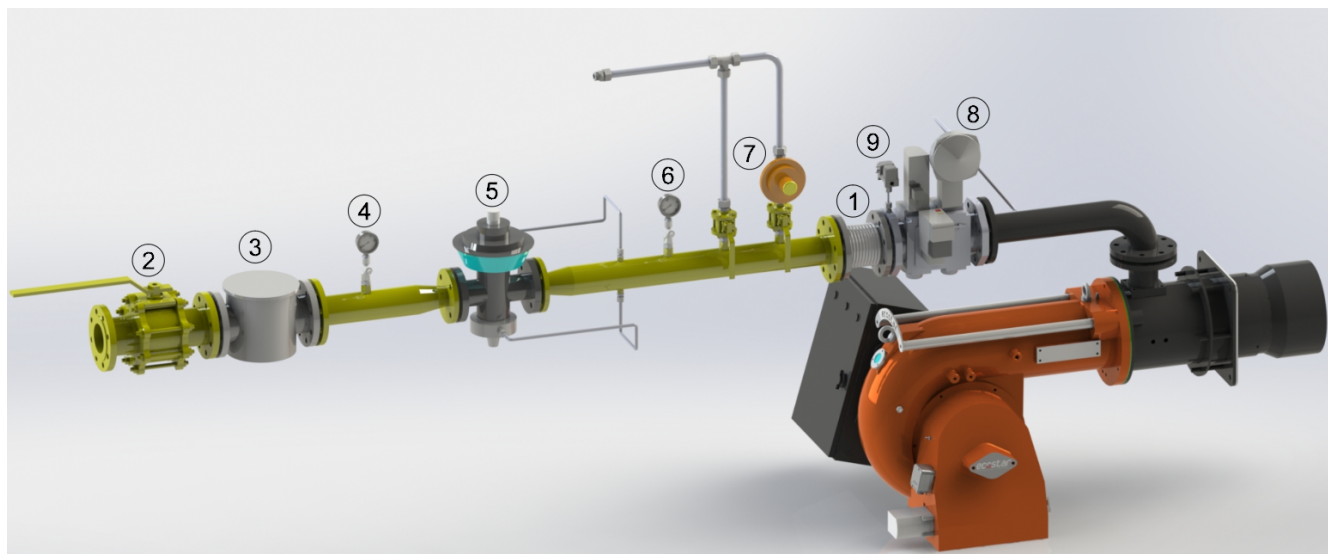

Pe < 300 mbar Q<1200kW	Pe > 300 mbar Q<1200kW	Pe < 300 mbar Q>1200kW	Pe > 300 mbar Q>1200kW
1- Compensator	1- Compensator	1- Compensator	1- Compensator
2- Ball valve	2- Ball valve	2- Ball valve	2- Ball valve
3- Gas filter	3- Gas filter	3- Gas filter	3- Gas filter
4- Inlet manometer + valve	4- Inlet manometer + valve	4- Inlet manometer + valve	4- Inlet manometer + valve
8 – Multi-block (safety and operation solenoids)	5- Regulator	8 – Multi-block (safety and operation solenoids))	5- Regulator
9- Sealing Control Set	6- Outlet manometer + valve	9- Sealing Control Set	6- Outlet manometer + valve
	7- Safety discharge valve		7- Safety discharge valve
	8 – Multi-block (safety and operation solenoids)		8 – Multi-block (safety and operation solenoids)
	9- Sealing Control Set		9- Sealing Control Set



Threaded and flanged connections may vary depending on the gas pressure and consumption.

9. MAINTENANCE

9.1. Monthly Maintenance

Monthly maintenance is a comprehensive process where general checks of burner and peripheral components are performed to prevent possible faults. After completion of maintenance and adjustment processes, make sure to perform an emission analysis.

- Clean the filters on the main line and multiblock.
- Check the burner gas tip.
- Perform insulation measurements of ignition and ionization electrodes, replace electrodes should there be leakage to the body.
- Check ignition cables and sockets.
- Check all wiring points. Tighten loose connections.
- Clean the dust and layers accumulated on the fan and air klappes.
- Check gas line pressure, it must be the same with the first adjusted pressure, otherwise burner load and emission values will also have changed.
- Check all bolts of the burner. Tighten loose bolts.
- After starting the burner and adjusting air klappe, perform flue gas emission measurement and check if there is an ideal combustion.

9.2. Seasonal Maintenance

Comprehensive maintenance work when the burner is re-started after long periods of shut-down or interruptions. After completion of maintenance and adjustment processes, make sure to perform a combustion analysis.

- Check insulation resistance of electric motor.
- Replace ignition and ionization electrodes with new ones.
- Clean air fan and clamps.
- Check the operating function.
- Check boiler thermostats.
- Check cleanliness of boiler inside and clean if necessary.



Follow installation directions during maintenance.

9.3. Installation And Disassembly Instructions For Maintenance Purposes

ECO 1

For Intervention to Ignition System

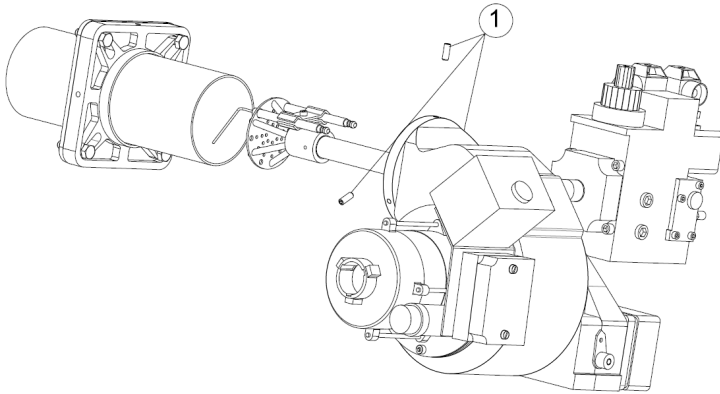

- Remove 3 bolts number 1, which fix the flame tube on the Body, and pull back and lower the body provided that the flame tube stays on the boiler. Make the necessary intervention to ignition and ionization circuit.

For Intervention to Fan and Motor:

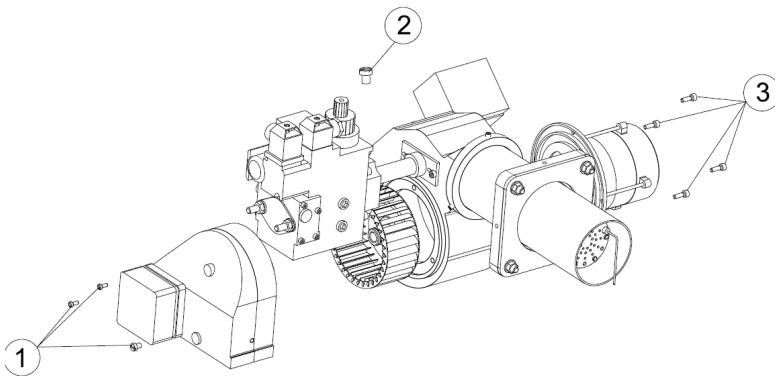

- Remove cable of the electric motor from program relay.
- Remove bolts number 1 that connect the air vent to the body. Detach the air vent from the body.
- In order to take the fan out of the electric motor, remove the bolt number 2 in fan core and interfere the fan.
- Remove the bolts number 3 on the electric motor and take the motor off the body.

For Intervention to the Air Klappe:

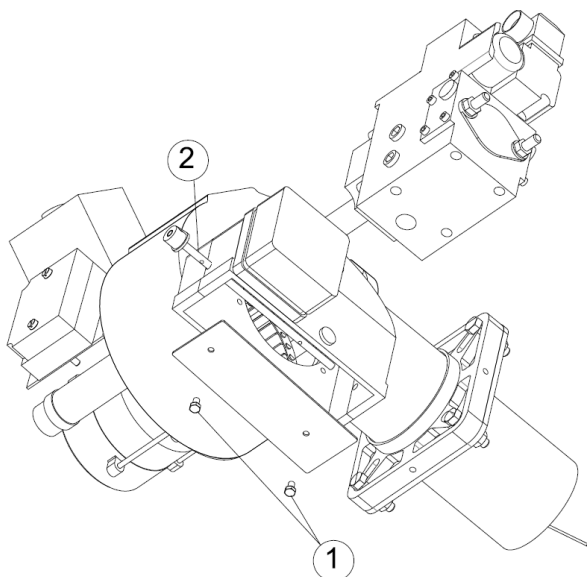

- Remove 1 bolts number 2 that fix the klappe on the shaft. Detach the klappe and the shaft number 2 from the body.

ECO 2

For Intervention to Ignition System

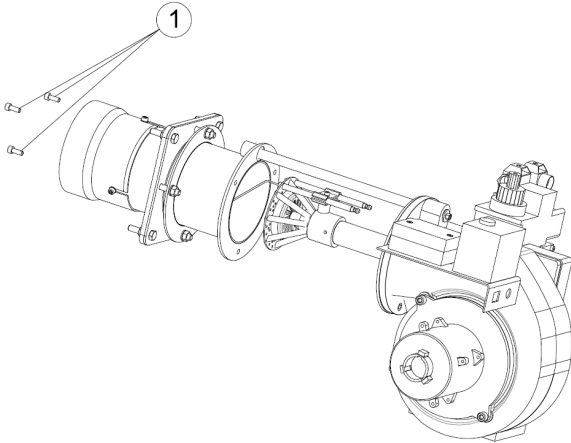

- Remove 3 bolts number 1 that fix the body on the flame tube and pull back the body by sliding it on the lift shaft.

For Intervention to Fan and Motor:

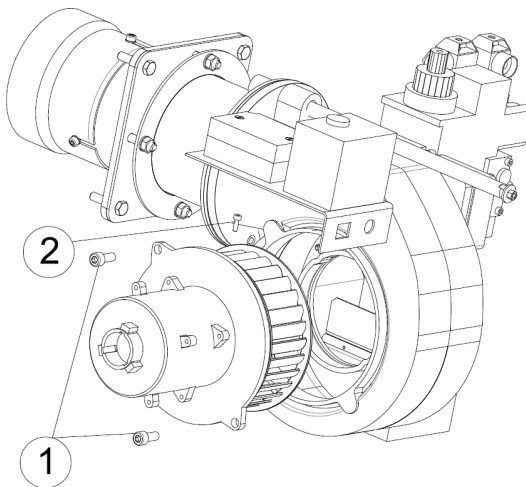

- Remove cable of the electric motor from program relay.
- Remove bolts number 1 that connect the electric motor to the body. Detach the motor and the fan from the body.
- In order to take the fan out of the electric motor, loosen the bolt number 2 in fan core.

For Intervention to the Air Klappe:

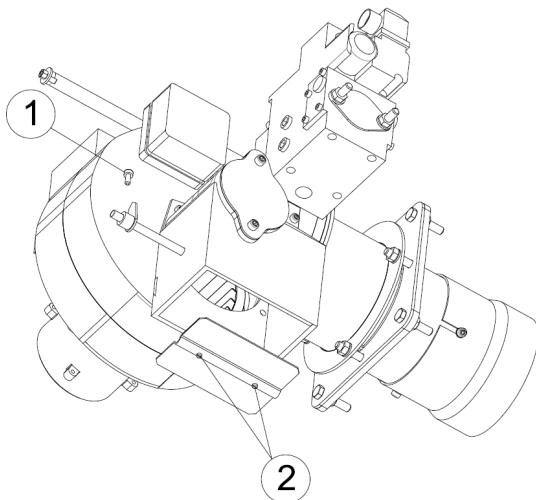

- Remove the bolt number 1 from the shaft. Remove 2 bolts number 2 that fix the klappe on the shaft. Detach the klappe and the shaft from the body.

ECO 30, ECO 45

For Intervention to Ignition System

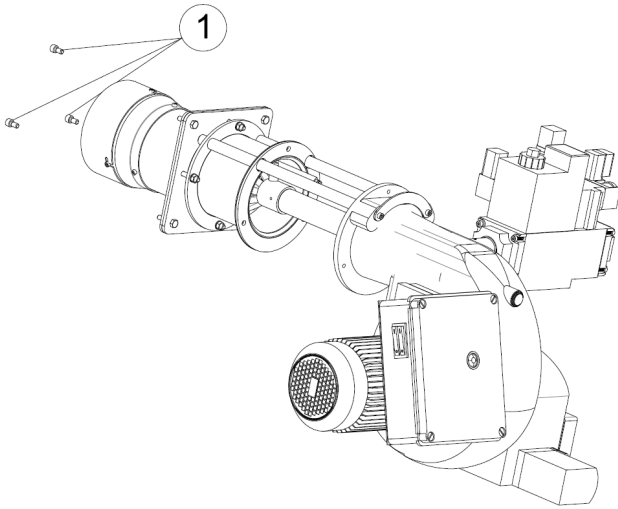

- Remove 3 bolts number 1 that fix the body on the flame tube and pull back the body by sliding it on the lift shaft.

For Intervention to Fan and Motor:

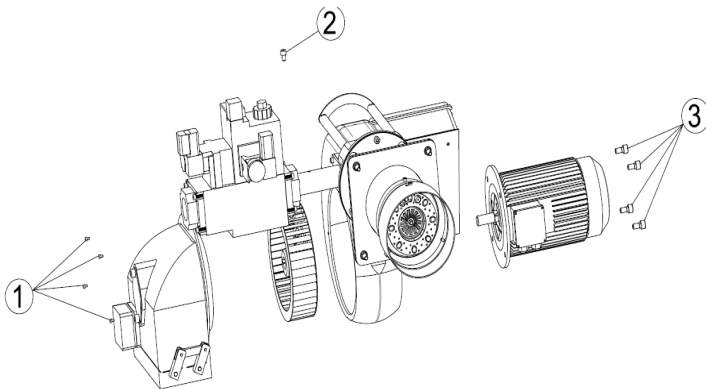

- Remove cable of the electric motor from program relay.
- Remove bolts number 1 that connect the air vent to the body. Detach the air vent from the body.
- In order to take the fan out of the electric motor, remove the bolt number 2 in fan core and interfere the fan.
- Remove the bolts number 3 on the electric motor and take the motor off the body.

For Intervention to the Air Klappe:

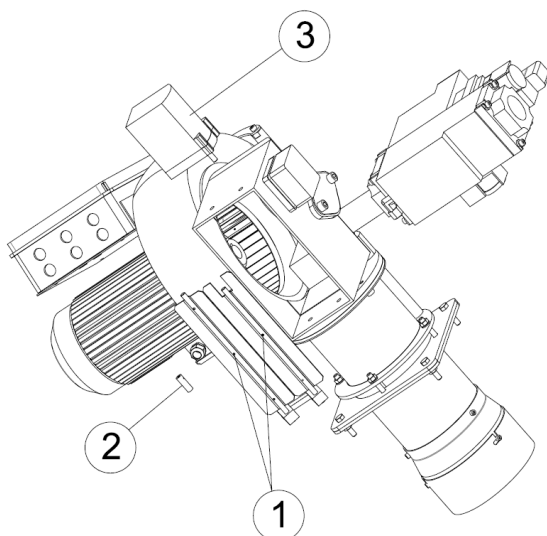

- Remove bolts number 1 that fix the klappe on the mil.
- Detach servomotor expanding bushing number 2 after detaching the klappe.
- Detach servomotor number 3 and shaft from the air vent.

10. TROUBLESHOOTING

Problem	Cause	Explanation-Suggestion
Burner cannot be commissioned	Gas is cut or does not come	Gas valve might be closed. Open the valve.
	Fuse failure	Check burner power supply. The fuse on the main panel or the fuse on the burner might be tripped.
	Relay failure	Reset the thermal relay. Check adjustment of the thermal relay according to the current in motor label. If the failure is not removed, replace the thermal relay.
	Boiler thermostat, pressure switch failure	If there is a problem with the burner thermostats, pressure switches and steam tank this may be due to an unadjusted or faulty water level device; adjust it and if broken, replace it.
Flame appears and goes into failure mode.	Gas pressure error	Supply gas pressure might be low.
	Ionization electrode failure	Ionization electrode may be faulty or contaminated. Remove and clean.
	Program relay failure	Replace it with a new one.
Burner starts up, but fails after 10 seconds.	Air pressure switch adjustment	Air pressure switch might be adjusted to a high value. There may be dirt in the air pressure switch. Air pressure switch might be broken.
	Program relay failure	Replace it with a new one.
	Fan motor failure	Check fan motor coils, motor contactor and outlet from program relay.
Burner starts up, but fails after 30 seconds.	Gas valve, gas pressure drop	Gas valve might be closed. Supply gas pressure might be low. Check gas inlet manometer.
	Ignition electrode failure	Ignition electrodes might be misadjusted or ignition cables might have come out of their terminals. Adjust ignition electrodes with a distance of 3-5 mm. between them.
	Gas valve adjustment	Check the starting setting of the gas valve. Burner must be adjusted to sufficient start gas flow for its activation.
Boiler cover is overheating.	Sealing problem	Ensure sealing between the boiler cover and burner. If required, use insulating material between the boiler connecting flange and boiler cover.

12. AFTER-SALES SERVICES

Dear Customer,

We believe that providing a good service is as important as providing a good product. Therefore, we continue offering wide range of comprehensive services to our conscious customers.

For your suggestions, complaints and service requests
Esentepe Mah. Milangaz Cad. No:75 K:3
Kartal Monumento Plaza
KARTAL/İSTANBUL/TÜRKİYE
Tel: 444 8 326
Fax: +90 216 370 45 03

Factory Contact Details
Türkgücü OSB
Bülent Ecevit Bulvarı No:11
ÇORLU/TEKİRDAĞ/TÜRKİYE
Tel: +90 282 685 44 80-81
Fax: +90 282 685 42 09

Also you can contact with us:
Web site : www.ecostar.com.tr
E - mail : servis@ecostar.com.tr



Please observe the following recommendations.

- Use the product in accordance with the principles of this manual.
- For any service demands regarding the product, please contact our Service Center from the abovementioned phone numbers.
- Upon your purchase, register your warranty certificate during installation.

