

MONOBLOCK DUAL FUEL (GAS-LIGHT OIL) BURNERS INSTALLATION, OPERATING AND MAINTENANCE MANUAL

ONE STAGE, TWO-STAGE AND MODULATING OPERATION

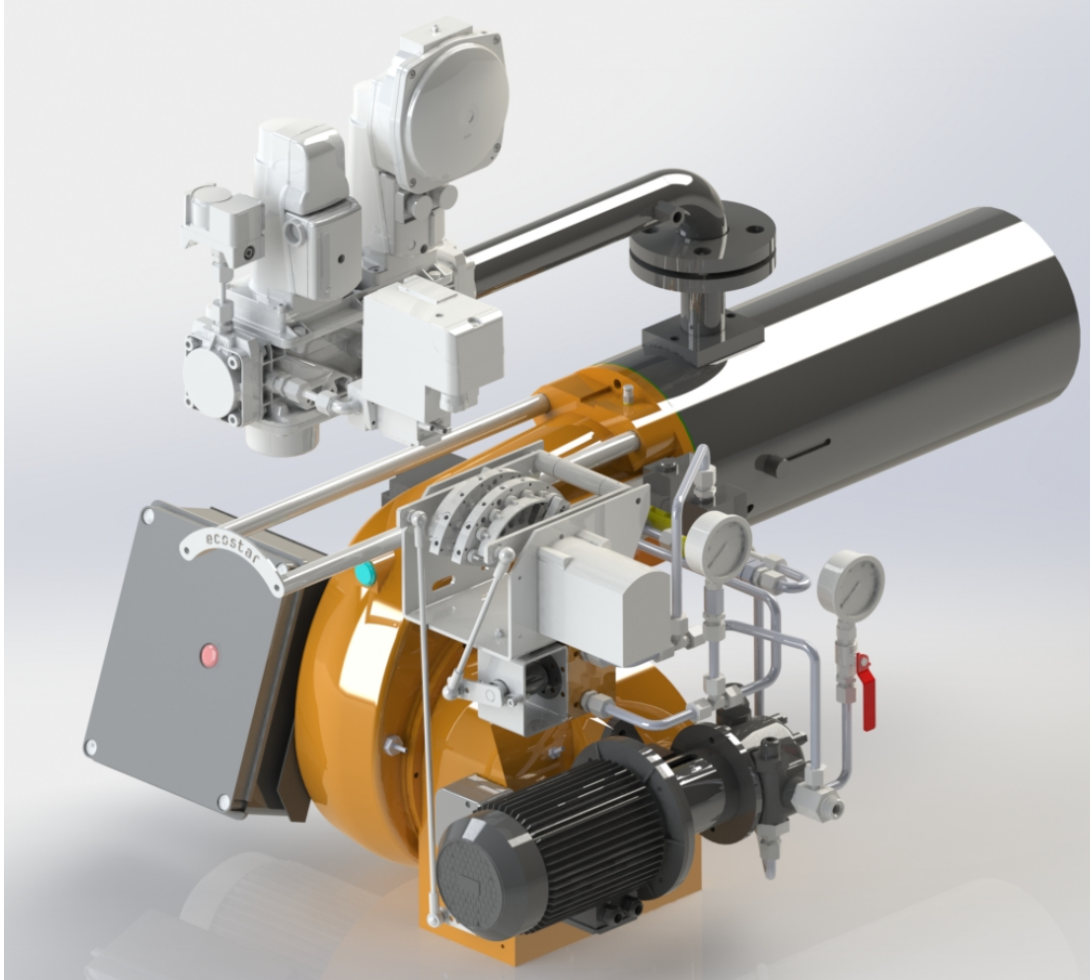

ECO 2
ECO 30
ECO 45



DEAR USER,

ECOSTAR **ECO 2, ECO 30, ECO 45 Dual Fuel (Gas-Light Oil)** burners are prepared and manufactured according to the latest technical developments and safety rules. It is easy to use for our customers.

We recommend that you read this manual and safety warnings thoroughly before the use of the device in order to ensure safe, cost effective and environmental-friendly use.

If you encounter any issue that is not explained clearly in this manual or you could not understand, please contact with our service department.

We thank you for choosing ECOSTAR brand.

Ecostar Dual Fuel (Gas-Light Oil) Burners are manufactured in compliance with TS EN 267 and TS EN 676 + A2 standards.







This Operating Manual is an integral part of the burner and must be maintained in a plastic dossier and hung at a clearly visible place in the burner room.

CONTENTS

1. WARNINGS.....	3
1.1. Warning Symbols and Descriptions.....	3
1.2. General Safety Rules.....	4
2. TERMS OF WARRANTY	6
2.1. Out of Warranty Conditions	6
3. BURNER’S GENERAL FEATURES.....	7
3.1. Purpose of Use and Work Limits of Burners	7
3.2. Code Key.....	7
3.3. Burner Components	9
4. GAS, FLUE GAS AND HEATING WATER SCHEMA	15
5. TECHNICAL DATA.....	16
5.1. Capacity Table.....	16
5.2. Back Pressure-Capacity Diagrams.....	17
5.3. Burner Dimensions	18
5.4. Gas Hood Pressure Loss Diagram	19
5.5. Flame Length and Diameter	20
5.6. Noise Level.....	20
6. BURNER HANDLING INFORMATION.....	21
7. INSTALLATION	22
7.1. Burner Installation Picture.....	22
7.2. In reverse flame front mirror boilers.....	23
7.3. In cylindrical (straight flame) boilers	23
8. COMMISSIONING	24
8.1. Before Commissioning.....	24
8.2. General Controls	24
8.3. Combustion Adjustment.....	26
8.4. Fuel Pumps	26
8.5. Gas Adjustment	31
8.5.1. VGD 20 4011 - 5011 Series Gas Valve.....	31
8.5.2. MB DLE Series Monoblock Gas Valve	32
8.5.3. MB ZRD(LE) 405 – 412 Series Gas Valve	34
8.6. Air Pressure Switch Adjustment.....	35
8.7. Servomotor Adjustment	35
8.8. Emission Measurement	36
8.9. Program Relay	36
8.10. Light Oil Burner Fuel Ring Line.....	39
8.11. Gas Pass Equipment Required in Gas Line	40
9. MAINTENANCE	41
9.1. Weekly Maintenance.....	41
9.2. Monthly Maintenance	41
9.3. Seasonal Maintenance.....	42
10. TROUBLESHOOTING	43
11. PERIODICAL FLUE GAS MEASUREMENT REPORT.....	44
12. AFTER SALES SERVICES.....	45
13. NOTES	46

1. WARNINGS

1.1. Warning Symbols and Descriptions

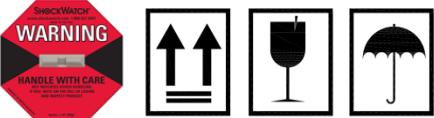
Symbols	Symbol Descriptions
	Important information and useful hints.
	Warning of danger to life or property.
	Warning of electrical voltage.
	Product handling information.
<p data-bbox="363 1167 400 1196">P_F</p>	Impulse connection detecting combustion chamber pressure
<p data-bbox="363 1317 400 1346">P_L</p>	Impulse connection detecting combustion air pressure
<p data-bbox="357 1467 406 1496">P_{BR}</p>	Impulse connection detecting burner gas head
 <p data-bbox="320 1599 539 1671">CLEAN THE GAS BURNER. CLEAN GAS LINE. ЧИСТАЯ ЛИНИЯ ГАЗ.</p>	"Clean the gas line" warning on gas line.
	Electric motor direction of rotation
	Carry in an upright position. Fragile Item. Protect against water.

1.2. General Safety Rules

- All personnel engaged in installation, disassembly, commissioning, operation, control, maintenance and repair should have received the necessary training, qualified and fully read and understood this manual.
- No changes that might damage the safety of the burner unit must be made by persons and/or organizations on the burner unit.
- All operation, commissioning and installation works (except for burning adjustment) should be carried out when the burner is not operating and after disconnecting the power supply. Noncompliance with these rules may lead to serious bodily injuries and even death by electrical shocks or uncontrolled flame formation.
- Repairs concerned with safety elements should be carried out only by the manufacturing company.
- The device should never be used by children, mentally handicapped and inexperienced persons.
- Children must not be allowed to play with the device.
- Keep the device away from explosive and flammable materials.
- Device must intake air, ventilation and air discharge holes must not be closed.



If you sense gas leakage;

- Shut down valves of all gas devices.
- Open all doors and windows.
- Do not turn on electric devices or do not turn them off if they are working.
- Do not use burner derived tools such as match and lighter.
- Inform the gas company.



Do not store any inflammable materials in boiler room.



Wear hearing protectors if there is noise in boiler room.



In case of fire or other emergency;

- Switch off the main switch
- Close the main fuel shut-off valve outside the plant.
- Take appropriate actions



The burner installation must be carried out in accordance with the instructions. Vibration can damage the burner and its components.



Keep boiler doors closed while starting burner and during burner operation.



Check combustion values to be correct by using flue gas analyzer at the whole adjustment range between minimum, full load, and ignition load.



Use lifting device or belt for lifting fan motor, if necessary



During the first commissioning of the burner or in case of any revision carried out in the electrical system or motor cables by any reason, direction of the fan rotation must certainly be checked by the authorized technical service.



For products that have not been commissioned or started more than 6 months, before activating the servomotor;

In gas, air dampers and oil regulators, servomotor and damper connections must be checked to ensure that they are free running in spite of immobility and oil freezing.



BURNER ROOM

Install the burner in a suitable room/floor with minimum external air openings and sufficient to ensure perfect combustion, in compliance with current regulations.

Never obstruct air openings of the burner room, burner fan intake vents or air ducts in order to prevent:

- a. The build up of toxic / explosive gas mixtures in the burner room,
- b. Combustion with insufficient air, resulting in hazardous, anti-economical and polluting operation.

The burner must be always protected from rain, snow and frost to prevent corrosion and paint deformations.

Keep the burner room clean and free of solid volatile substances, which could be sucked into the fan and clog the internal burner or combustion head air ducts.

2. TERMS OF WARRANTY

Main and auxiliary equipment and all components used in Ecostar Dual Fuel (Gas-Light Oil) burners are guaranteed for 1 year by TERMO ISI SİST. A.Ş starting from the date of commissioning under the maintenance, adjustment, operating conditions and relevant mechanic, chemical and thermal effects explained herein.



Please note that this warranty is only valid if the device(s) is commissioned and maintained by our authorized services.



Our company reserves the right to make any modifications on the product and all instructions thereof for improvement purposes.

2.1. Out of Warranty Conditions

- Any damage arising out of or in relation to customers' non-compliance to their responsibilities with regards to installation, commissioning, operation and maintenance,
- Any damage arising out of or in relation to commissioning, repairs and maintenance carried out by unauthorized services,
- Any damage that may occur during transportation or storage of the product,
- Not preserving the product in its original packaging until the installation stage,
- Incorrect and poor electrical connections, Failures due to incorrect voltage applications, frequent repetition of voltage fluctuations,
- Any damage that may occur as a result of incorrect fuel usage or, foreign substances in the fuel used or using of the product without any fuel,
- Any damage that may occur due to foreign particles entered into the product during installation and operation,
- Failures due to incorrect device selection,
- Any damage to unit due to natural disasters,
- Devices without any warranty certificates,
- Warranty Certificates without the stamp and signature of the authorized dealer or service,
- Devices with any falsification on the warranty certificate or without an original serial number.
- The risks during transportation of device under the responsibility of customer belong to the customer.
- Presence of misuse faults are indicated in the reports issued by authorized service stations or our authorized agent, dealer, representative or our factory in case of unavailability of authorized service stations.
- Customers may apply consumer protection arbitrator committee with regards to this report and request for an expert report.

3. BURNER'S GENERAL FEATURES

ECOSTAR Dual Fuel (Gas-Light Oil) burners are designed and manufactured to work with liquid fuel with max. 2.5- 6 Cst (mm²/s) viscosity. and Natural Gas and Liquid Petroleum Gas at gas pressures of min.20 mbar, max.300 mbar and at -%15 to +%10 of nominal voltages, under environmental temperature of max.60°C with rated capacity and burner pressure ranges.

3.1. Purpose of Use and Work Limits of Burners

- This product works at any load value equivalent to its max. capacity or covered by its capacity range;
 - In hot water and steam boilers,
 - In direct and indirect hot air generators,
 - Industrial appliances operating at temperature below 600 °C,
 - -15 °C...+60 °C ambient temperature range,
 - 1N 230 VAC/3N 380VAC /50 Hz feed voltage (-%15...+%10) values,
 - Max. 95% relative humidity,
 - In well-ventilated open and closed spaces compatible with protection class IP 40.



This device must never be operated with open flame!

3.2. Code Key

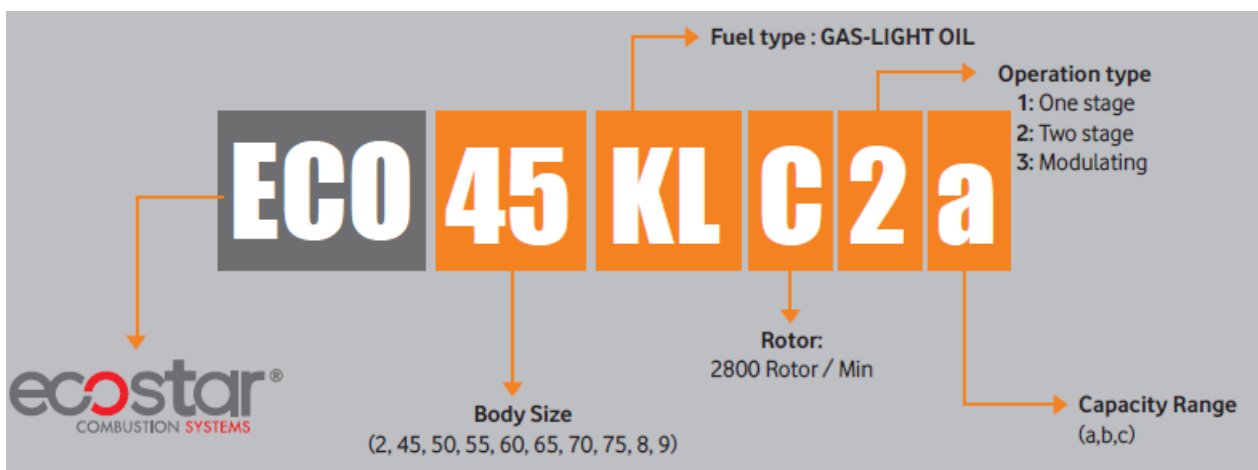

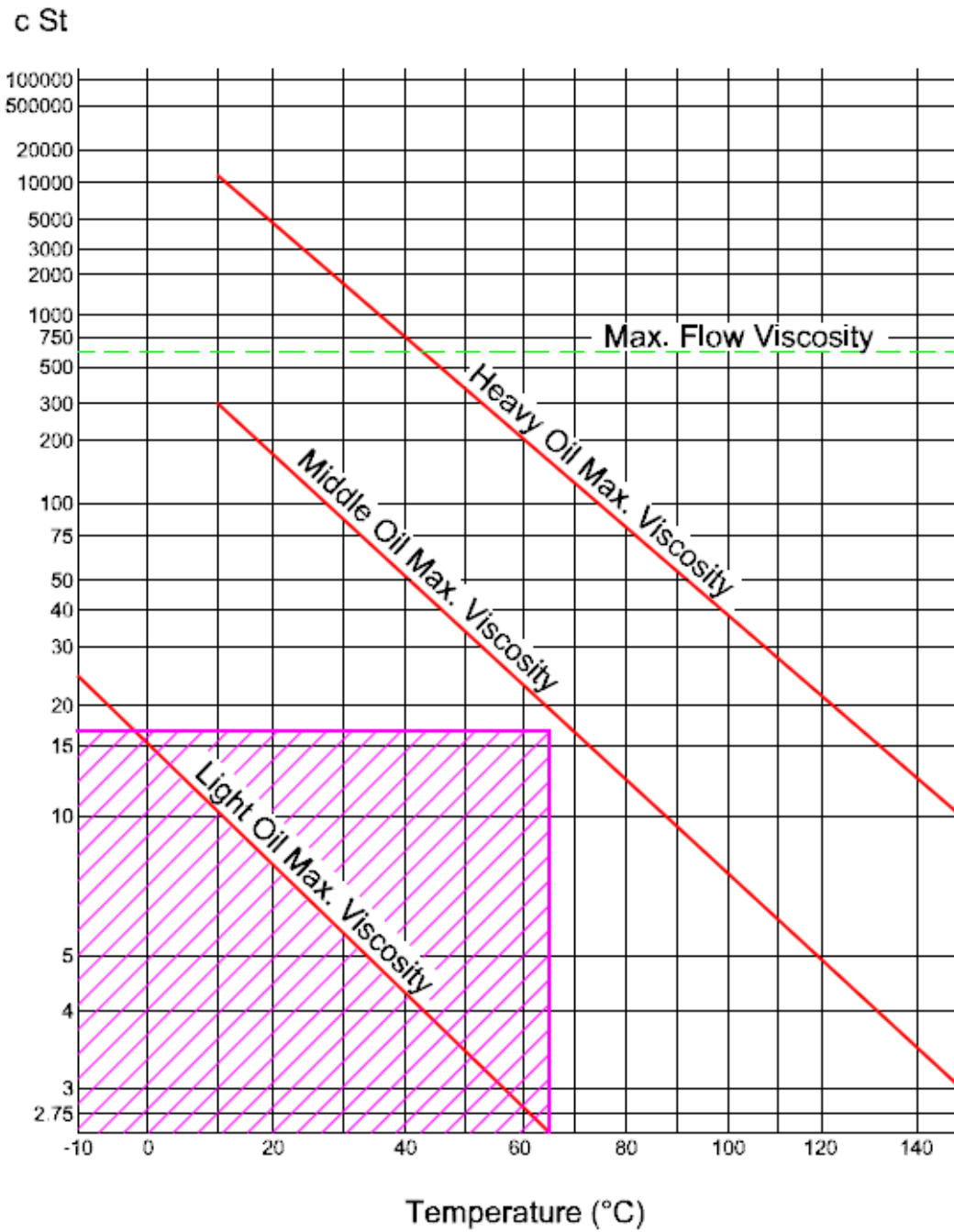

Temperature change of fuel used in ECOSTAR Dual Fuel (Gas-Light Oil) burners dependent on viscosity



Operating Range

3.3. Burner Components

ECO 2 KLC1-1a

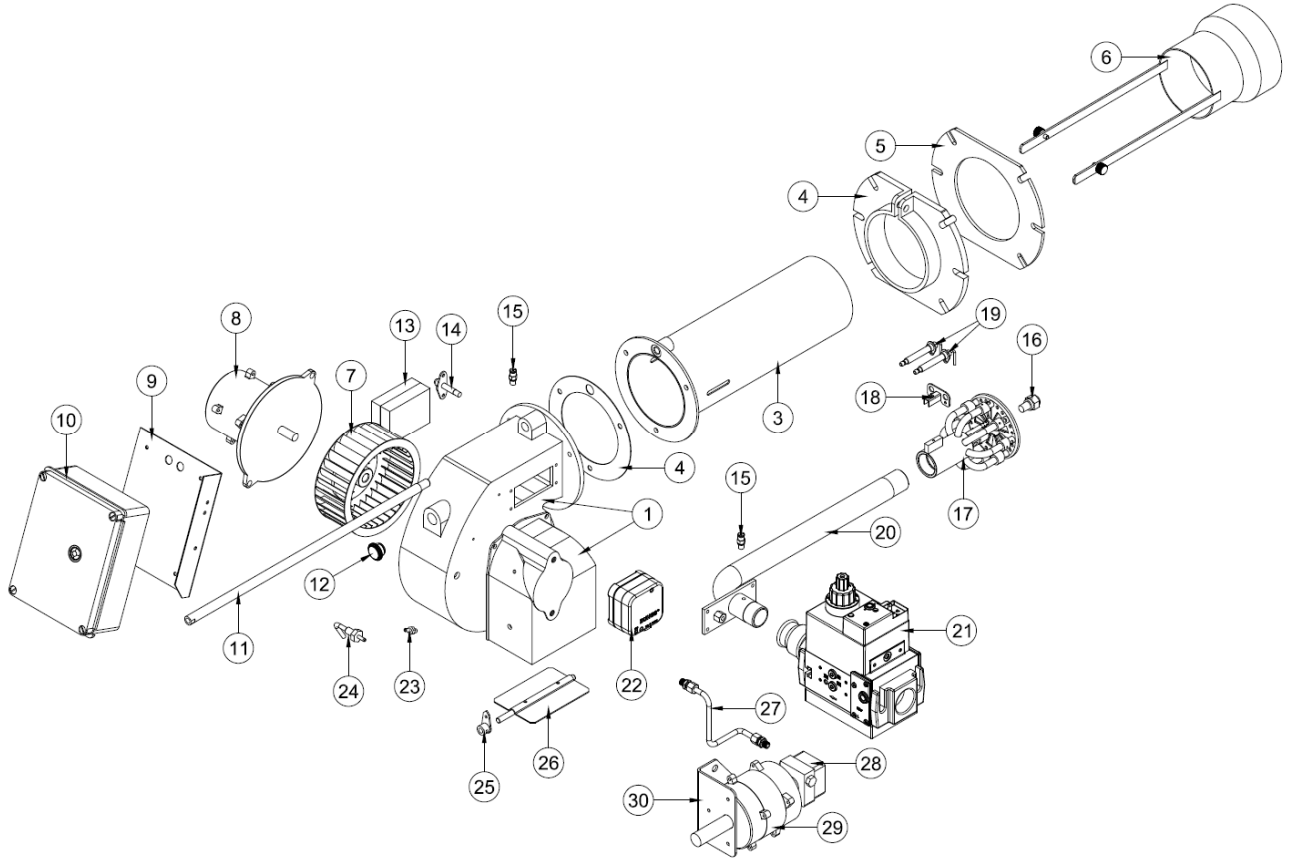

Assembly No	Part Name	Assembly No	Part Name
1	Body group	16	Fuel nozzle
2	Klingerit gasket	17	Combustion head
3	Flame tube	18	Electrode connection plate
4	Boiler connection flange	19	Ignition electrode
5	Gasket	20	Gas inlet pipe
6	Flame tube extension	21	Gas solenoid valve
7	Fan	22	Air pressure switch
8	Motor	23	Pressure switch adaptor
9	Electrical panel connection plate	24	Pressure switch adaptor
10	Electrical panel	25	Air damper gauge
11	Handling rod	26	Air damper
12	Observation glass	27	Fuel pipe
13	Ignition transformer	28	Pump
14	Photocell	29	Motor
15	Purger	30	Pump motor console

ECO 45 KLC2-2a-2b

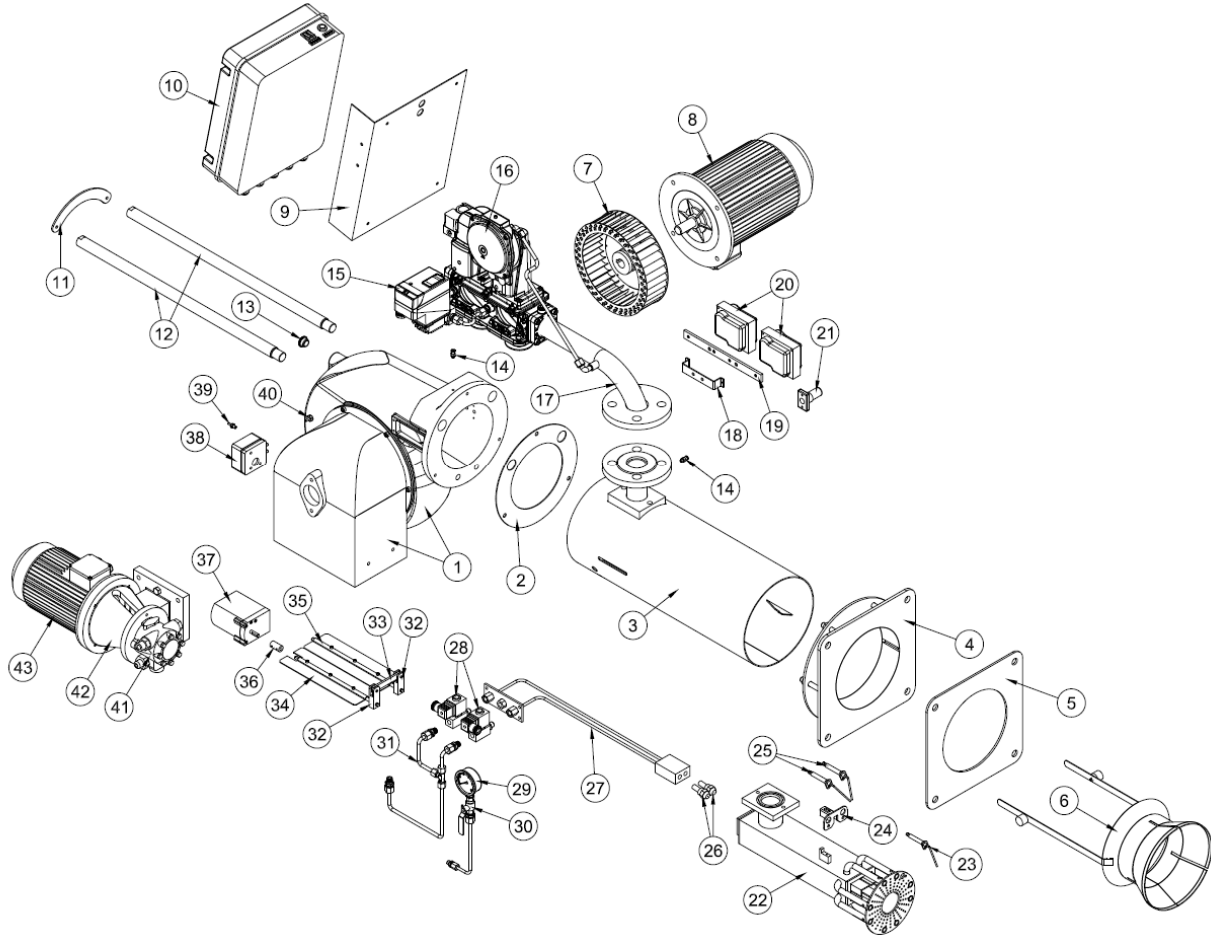

Assembly No	Part Name	Assembly No	Part Name
1	Body group	23	Gas Ignition electrode
2	Klingerit gasket	24	Electrode connection plate
3	Flame tube	25	Liquid fuel Ignition electrode
4	Boiler connection flange	26	Fuel nozzle
5	Gasket	27	Lance
6	Air Adjustment Mechanism	28	Solenoid valve
7	Fan	29	Manometer
8	Motor	30	Ball valve
9	Electrical panel connection plate	31	Fuel pipes
10	Electrical panel	32	Air damper motion rod
11	Handling rod fixing plate	33	Air damper transmission rod
12	Handling rod	34	Air damper
13	Observation glass	35	Air damper
14	Purger	36	Servomotor coupling
15	VPS	37	Servomotor
16	Gas solenoid valve	38	Air pressure switch
17	Gas inlet pipe	39	Pressure switch adaptor
18	Transformer connection plate	40	Pressure switch adaptor
19	Transformer connection plate(dual)	41	Pump
20	Ignition transformer	42	Pump motor console
21	Photocell	43	Motor
22	Combustion head		

ECO 45 KLC3b

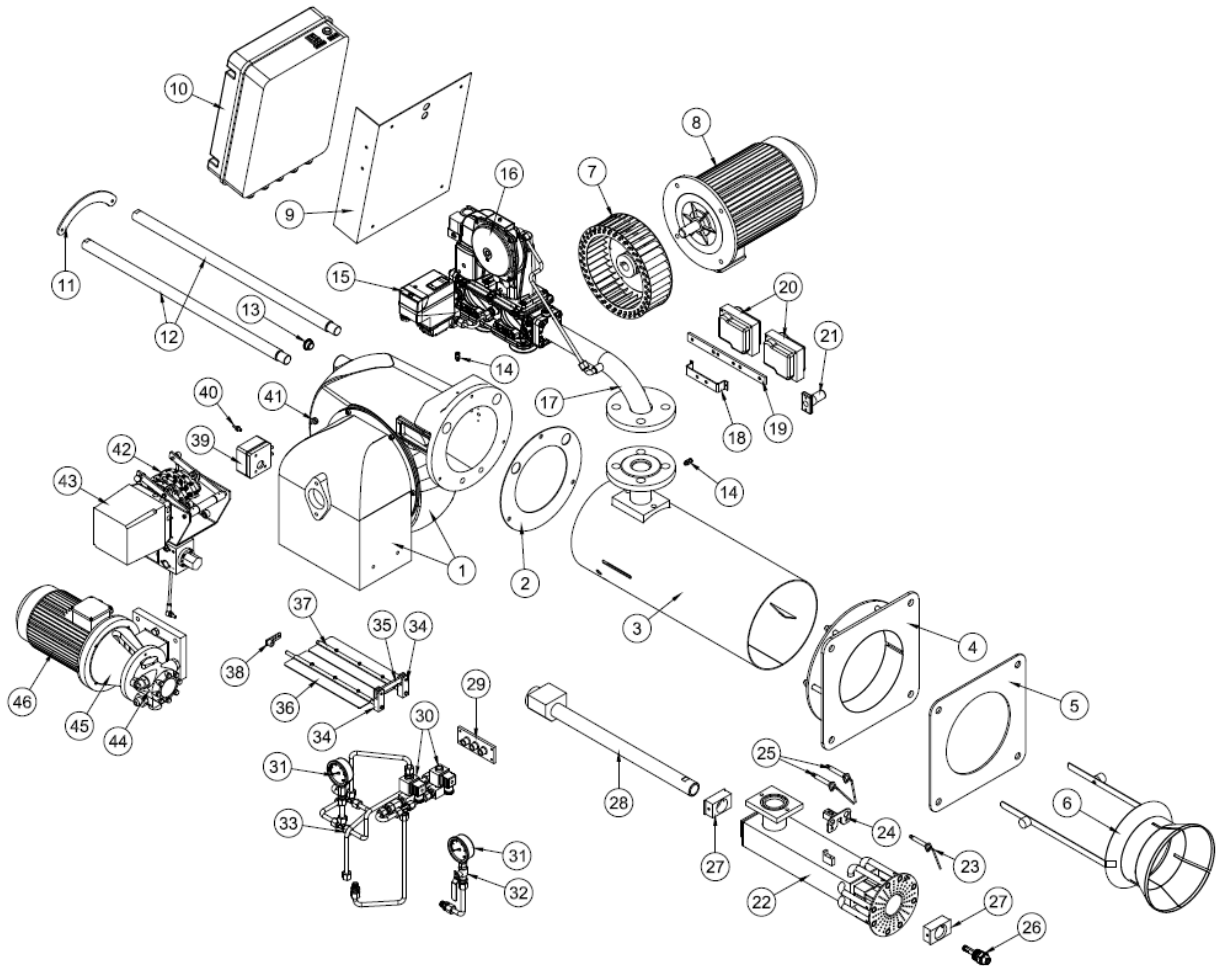

Assembly No	Part Name	Assembly No	Part Name
1	Body group	24	Electrode connection plate
2	Klingerit gasket	25	Liquid fuel Ignition electrode
3	Flame tube	26	Fuel nozzle
4	Boiler connection flange	27	Centring wedge
5	Gasket	28	Lance
6	Air Adjustment Mechanism	29	Solenoid valve connection plate
7	Fan	30	Solenoid valve
8	Motor	31	Manometer
9	Electrical panel connection plate	32	Ball valve
10	Electrical panel	33	Fuel pipes
11	Handling rod fixing plate	34	Air damper motion rod
12	Handling rod	35	Air damper transmission rod
13	Observation glass	36	Air damper
14	Purger	37	Air damper
15	VPS	38	Air dumper adjustment rod
16	Gas solenoid valve	39	Air pressure switch
17	Gas inlet pipe	40	Pressure switch adaptor
18	Transformer connection plate	41	Pressure switch adaptor
19	Transformer connection plate (dual)	42	Disc console group
20	Ignition transformer	43	Servomotor
21	Photocell	44	Pump
22	Combustion head	45	Pump motor console
23	Gas Ignition electrode	46	Motor

4. GAS, FLUE GAS AND HEATING WATER SCHEMA

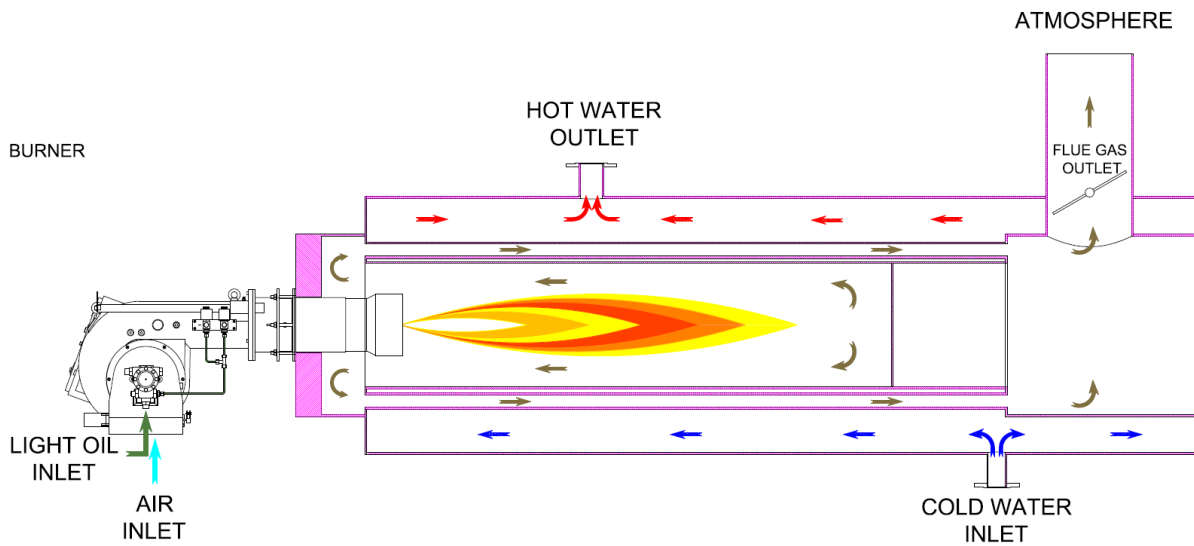
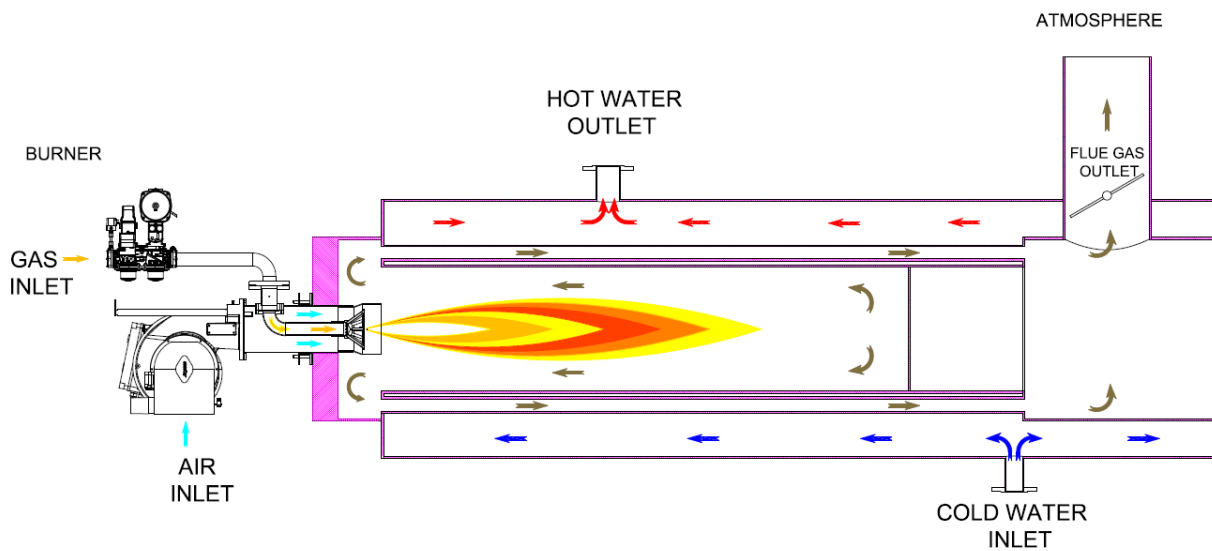

5. TECHNICAL DATA

5.1. Capacity Table

GAS-LIGHT OIL DUAL BURNERS CAPACITY TABLE															
BURNER TYPE	GAS CAPACITY		GAS CAPACITY		NATURAL GAS CONSUMPTION		LIGHT OIL CAPACITY		LIGHT OIL CAPACITY		LIGHT OIL CONSUMPTION		FAN MOTOR POWER	OIL PUMP POWER	MAIN SUPPLY
	Min. kcal/h	Max. kcal/h	Min. kW	Max. kW	Min. Nm ³ /h	Max. Nm ³ /h	Min. kcal/h	Max. kcal/h	Min. kW	Max. kW	Min. kg/h	Max. kg/h	kW	kW	VAC
ONE STAGE GAS-LIGHT OIL DUAL BURNERS															
ECO 2 K L C 1	51.600	172.000	60	200	6,3	20,8	77.400	144.480	90	168	7,6	14,2	0,15	0,15	1N240
ECO 2 K L C 1 a	86.000	299.280	100	348	10,4	36,3	96.320	251.120	112	292	9,4	24,6	0,15	0,15	1N240
TWO STAGE GAS/LIGHT OIL DUAL BURNERS															
ECO 45 K L C 2	172.000	645.000	200	750	20,85	78,18	172.000	645.000	200	750	16,86	63,24	0,75	0,37	3N400
ECO 45 K L C 2a	172.000	860.000	200	1000	20,85	104,24	212.420	851.400	247	990	20,83	83,47	1,1	0,37	3N400
ECO 45 K L C 2b	172.000	1.032.000	200	1200	20,85	125,09	212.420	1.014.800	247	1180	20,83	99,49	1,5	0,37	3N400
MODULATING GAS-LIGHT OIL DUAL BURNERS															
ECO 45 K L C 3b	172.000	1.032.000	200	1200	20,85	125,09	212.420	1.014.800	247	1180	20,83	99,49	1,5	0,37	3N400

H_u Natural Gas =8250 kcal/Nm³

H_u Light Oil (L) = 10200 Kcal/kg

5.2. Back Pressure-Capacity Diagrams

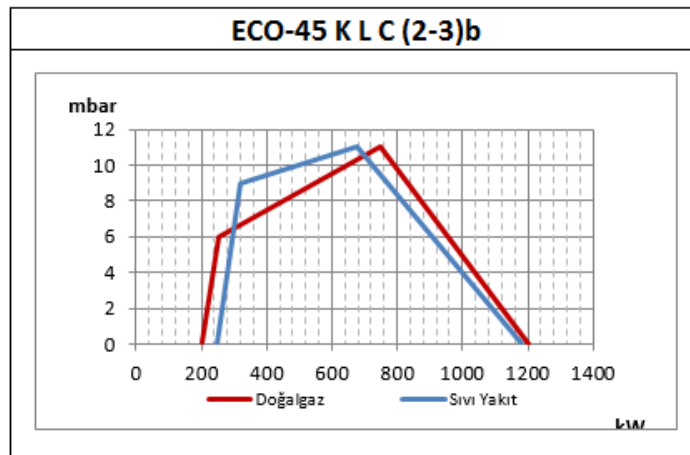
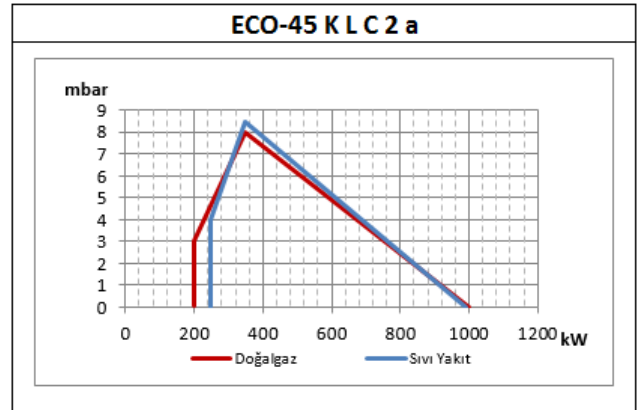
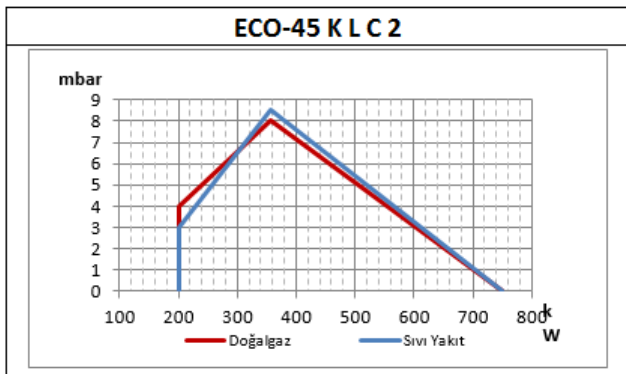
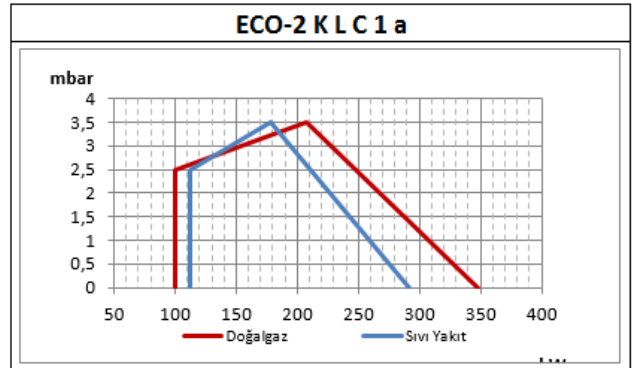
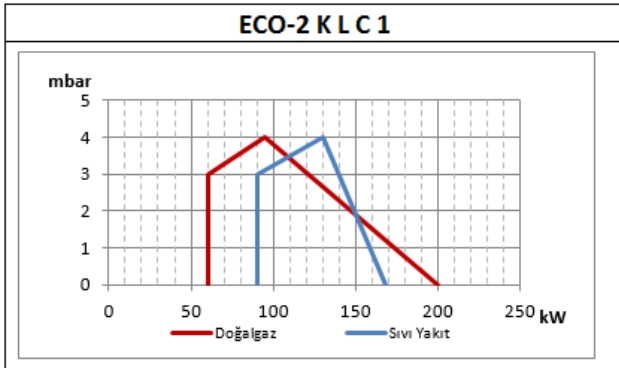

5.3. Burner Dimensions

ECO 2

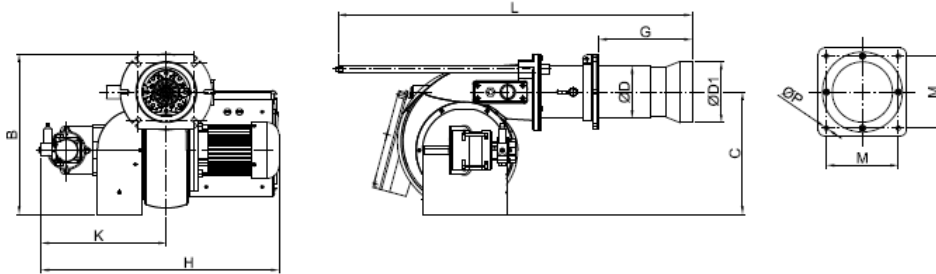

ECO 45

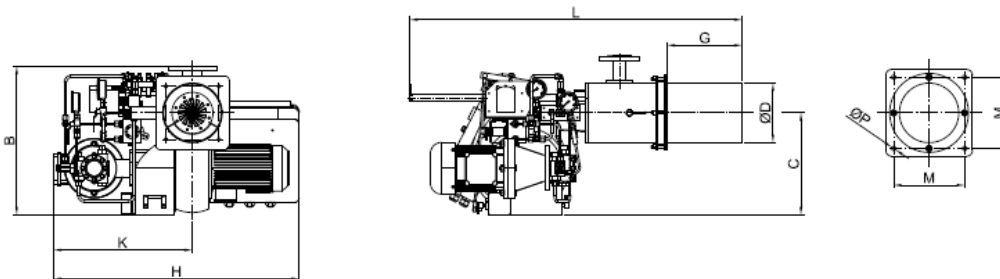

	L	Gmin	Gmax	H	K	B	C	ØP	M	ØD	ØD1
ECO 2 K (L)	950	106	320	560	335	320	230	10	142	120	139
ECO 45 K (L)	1040	150	260	750	400	680	350	12	180	148	172

5.4. Gas Hood Pressure Loss Diagram



Gas hood pressure loss measurements are conducted in atmospheric pressure. Consider the below data while conducting measurement in counter pressure boilers.

P_m : Gas hood pressure while burner is connected to the boiler and working

P_F : Combustion chamber pressure

P_{Br} : Burner net gas hood pressure

$$P_{Br} = P_m - P_F$$

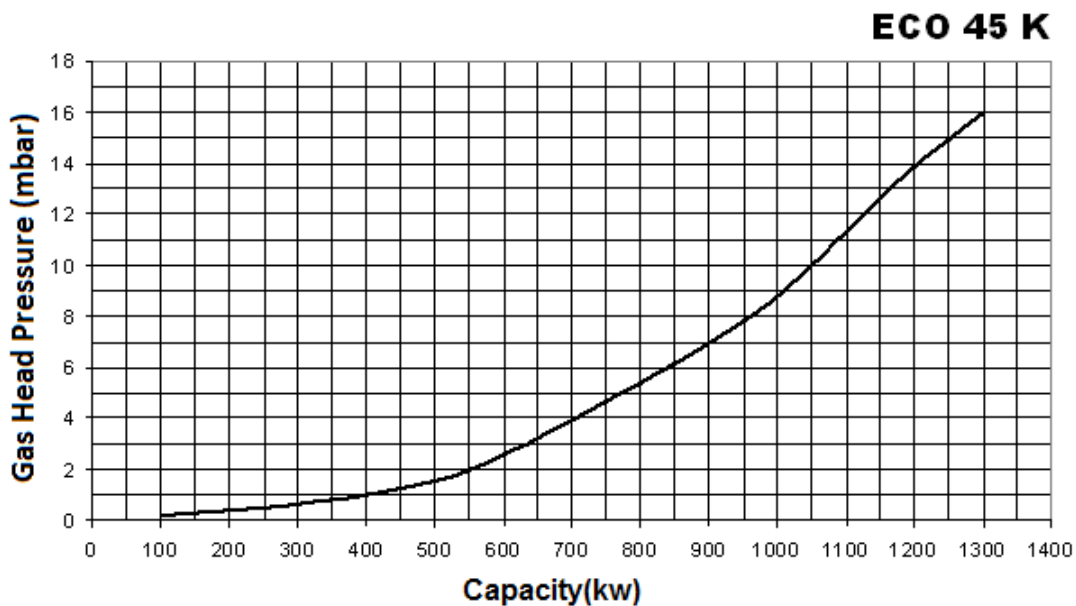
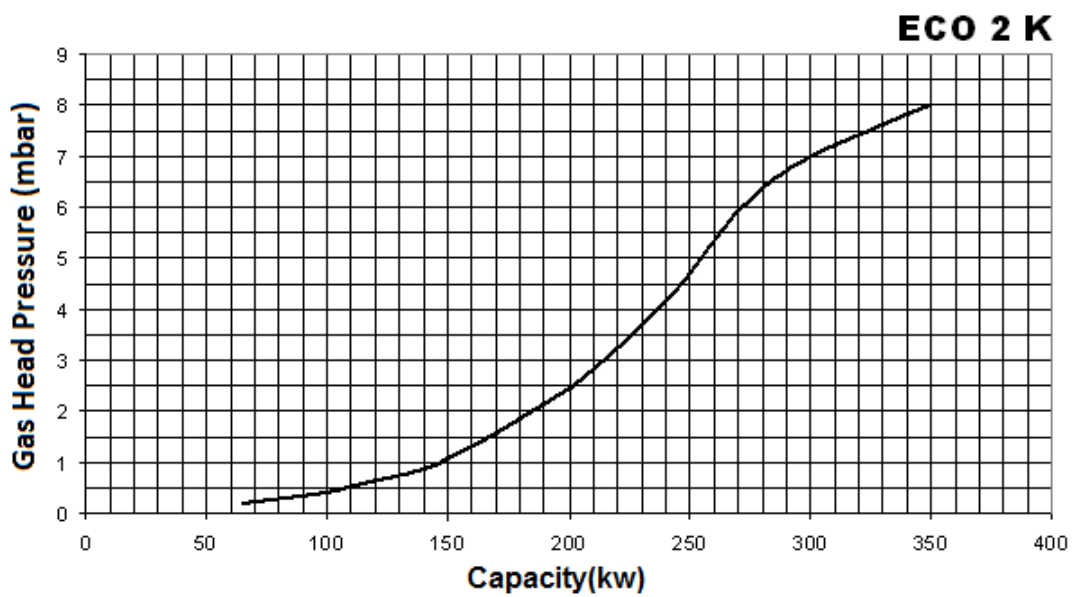

5.5. Flame Length and Diameter

Natural Gas

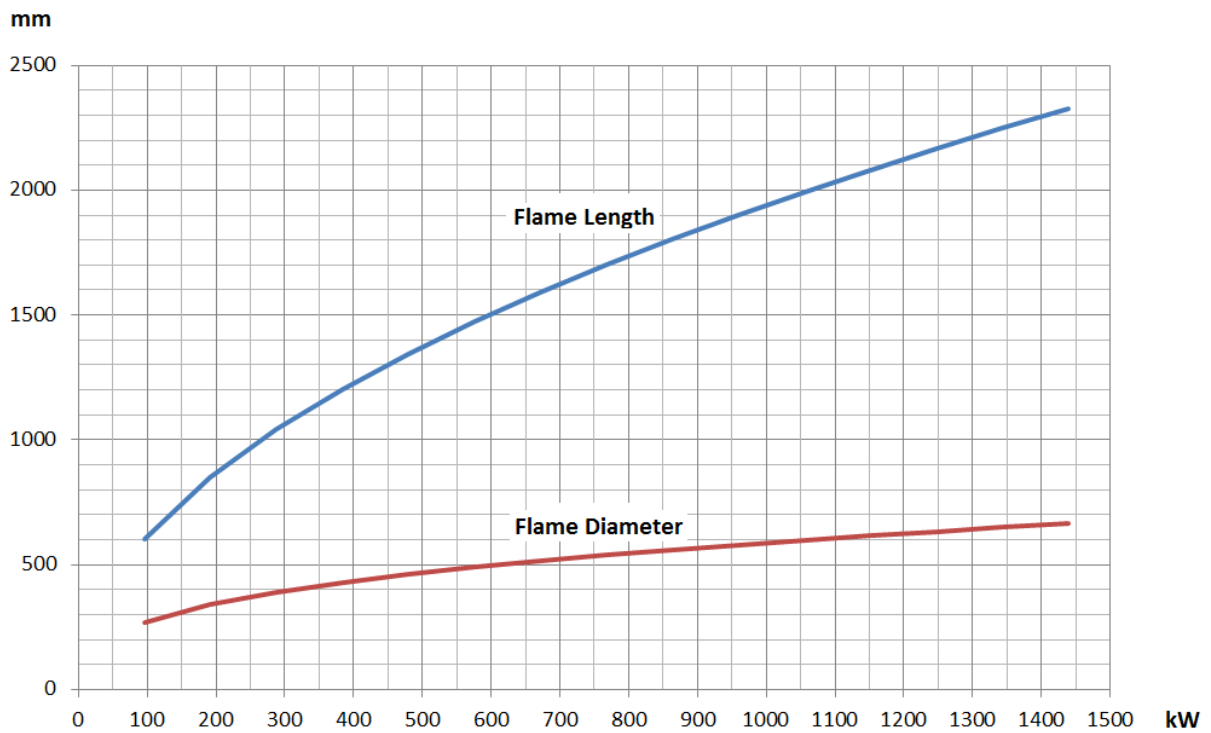

Light Oil

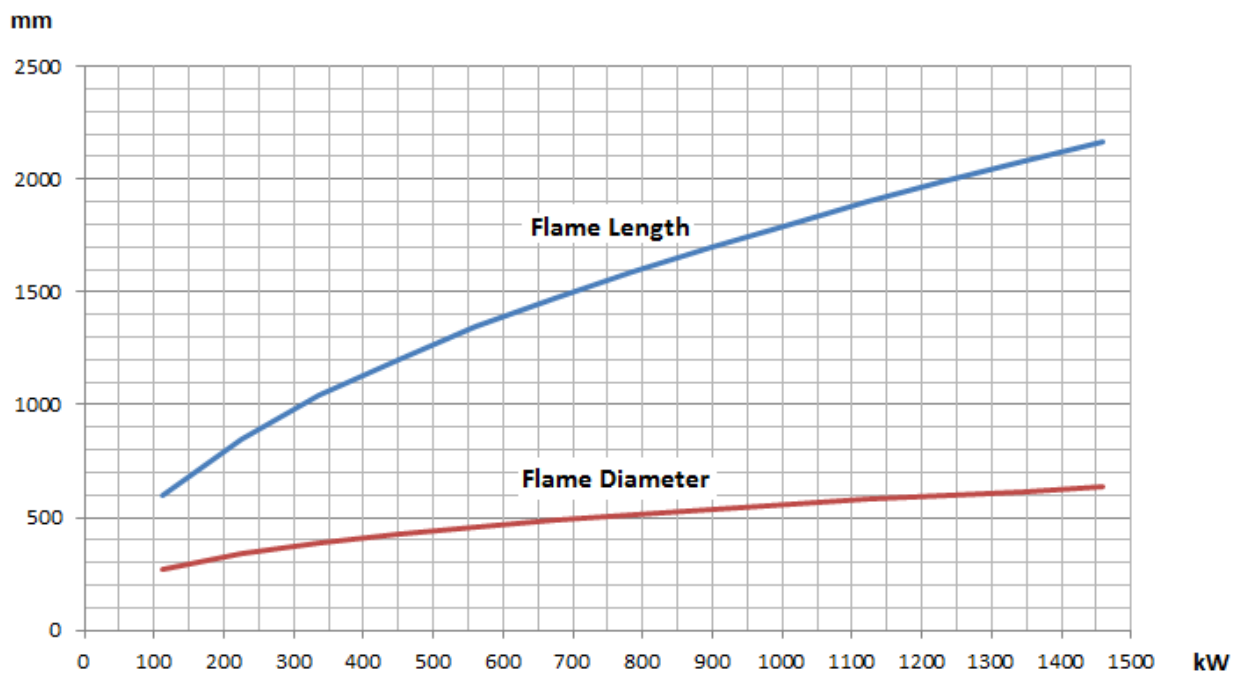

5.6. Noise Level

Product operates within the range of 75 decibels max. and 80 decibels.

6. BURNER HANDLING INFORMATION

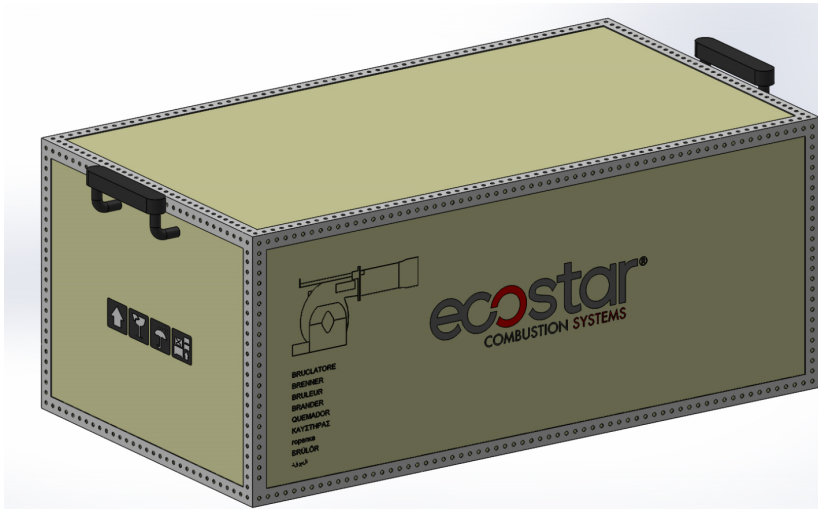

- Lift the product by holding the handles as seen in the picture.
- Prevent strong impacts on top of the product and vibration while handling the product.
- Do not leave the product in wet environment.



Dimensions of the box used for handling

Burner	L x W x H (cm)	Weight (kg)
ECO 2 KLC1	71 X 50 X 37	30
ECO 2 KLC1a	71 X 50 X 37	30
ECO 30 KLC2	115 X 80 X 53	100
ECO 45 KLC2	115 X 80 X 53	100
ECO 45 KLC2b	115 X 80 X 53	100
ECO 45 KLC3b	115 X 80 X 53	100

7. INSTALLATION

7.1. Burner Installation Picture

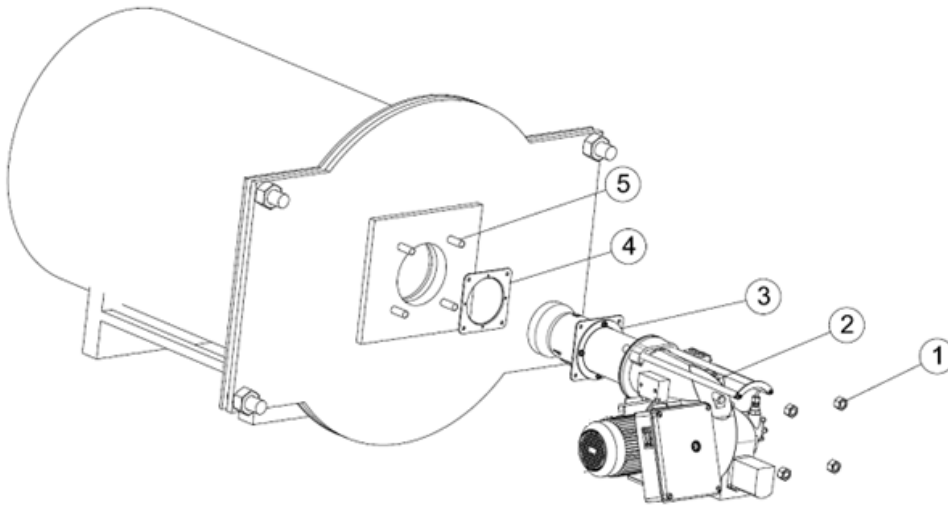

- 1- Drift Bolts
- 2- Burner
- 3- Boiler Connection Flange
- 4- Gasket
- 5- Boiler Studs

- In the installation of the burner, use the installation materials supplied with the burner.
- Secure the burner connection flange onto the burner cover by 4 bolts. Gasket must be connected such that it will remain between connecting flange and boiler cap.

After completing the installation of the burner on the boiler:

- Connect the oil feed pipes.
- Connect the burner panel to the mains by a cable suitable for the rated power.



Device must be shipped in original packaging!



Do not lift the device holding from servomotor, gas valve, impulse pipes or pressure switch during installation!



Clean the inside of fuel line thoroughly before installing the burner to the fuel line. Any damage that may occur due to solid objects and metal particles from the fuel line shall not be covered by our company.

7.2. In reverse flame front mirror boilers

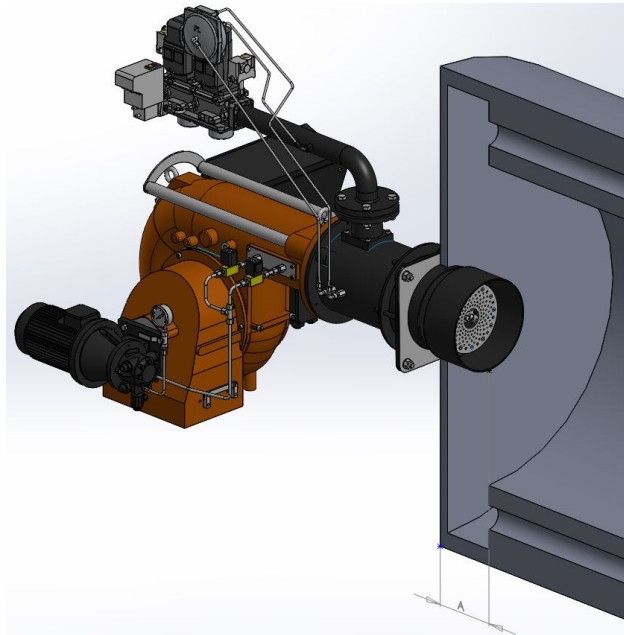

While installing the burner in reverse flame front mirror boilers, flame tube tip must be adjusted such that it gets inside by 50 mm-100 mm from flue pipes ($50\text{mm} \leq A \leq 100\text{mm}$). Otherwise flue gas temperature will rise and fuel consumption will increase.

7.3. In cylindrical (straight flame) boilers

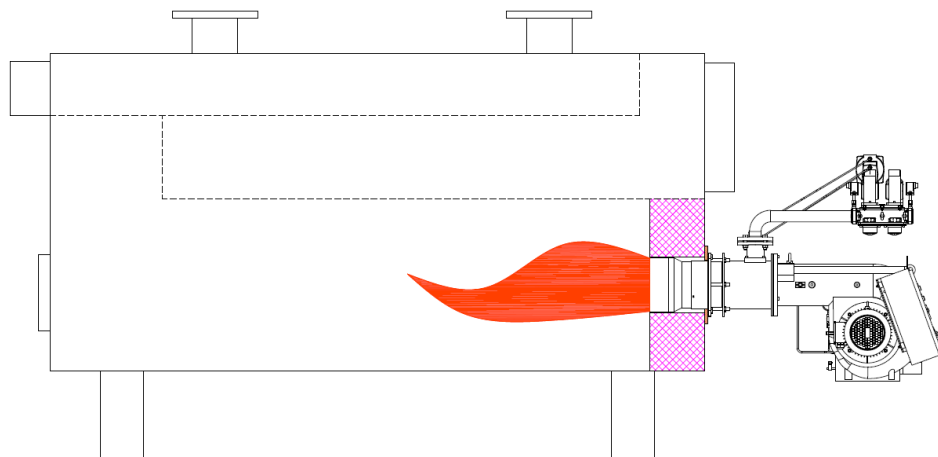

8. COMMISSIONING

8.1. Before Commissioning



Electrical Connection

Perform electrical connections according to the diagram provided with the burner. Follow general security rules during installation of electric wiring and making connections. Connect the earthing terminal in electric panel to the earthing installation.

8.2. General Controls



Make sure to perform the following controls before commissioning the burner.

- Installation of the burner to the boiler is checked.
- Check the fuel line (are the pipe diameters and the pipe installation correct?)
- Check energy input cables and voltages.
- Check the boiler safety thermostats and, if it is a two-stage burner, then make sure that there are two thermostats.
- Check the fuel nozzles according to the boiler capacity.
- Prior to operating the burner, control the boiler water level.
- Make sure water circulation system is turned on, and steam boiler and water feed pumps and boiler inlet - outlets are open.
- Is there electricity current?
- Is there gas?
- Has the boiler explosion lid been controlled?
- Is there sufficient air in boiler room (ventilation section $\text{cm}^2 = \text{boiler capacity kW} \times 7$)
- Has the air of the gas line been removed? Has a sealing test been made?

Commissioning order

Operating with Light Oil ;

- After performing the above mentioned controls, open the fuel tank valve.
- Open the valve upstream of the fuel filter.
- Check direction of motor rotation.
- Open the pump's vent plug and place the manometer (0-40 bar).
- Turn on the burner switch (turn to position 1).
- When the burner starts up, the motor is activated and turns the pump at the same time.
- The pump filter should be cleaned frequently (every 30 minutes) during the first commissioning, and please ensure that the fuel reaches the pump without interruption.
- It actuates pre-purge and discharges the residual gases remaining in the boiler from the funnel.
- After the pre-purge, fuel is delivered from the nozzle. The fuel meets the flame from the ignition electrodes and the combustion starts.
- After combustion of the burner, the pump pressure is adjusted (light-oil: 14 bar).
- If the burner has two stages, the switch is brought to position "2", and the capacity of the burner is increased through servomotor. Ideal combustion is obtained by increasing the amount of air by the fuel given according to analyses value.
- The boiler thermostat is adjusted as desired (70-90°C for central heating boilers).
- For the safety of the system, check the boiler thermostats and observe the deactivation of the burner.

Operating with Gas ;

Operation of one-stage burner

- Open the main gas valve, check the gas pressure from the manometer at the valve. (max.300 mbar)
- Check the boiler thermostat or pressure switch settings.
- Bring the operating switch on the burner panel to position 1.
- Burner fan motor will be activated.
- Ignition will take place at the end of pre-purge process.
- 3 sec. later, the gas valve will be opened and combustion will occur.
- Flame control system (ionization) will start flame control.
- After the boiler water heated up or the boiler pressure has risen, the burner will turn off.

Operation of two-stage burner

- Open the main gas valve, check the gas pressure from the manometer at the valve. (max.300 mbar)
- Check the boiler thermostat or pressure switch settings.
- Bring the operating switch on the burner panel to position 2.
- Burner fan motor will be activated.
- Ignition will take place at the end of pre-purge process.
- 3 sec. later, the gas valve will be opened and combustion will occur.
- Flame control system (ionization) will start flame control.
- Burner will switch to the second stage (max. capacity) according to the heat requirement.
- After the boiler water heated up or the boiler pressure has risen, the burner will turn off.

Operation of a modulating burner

- Open the main gas valve; check max 300 mbar gas pressure from the manometer.
- Open operating switch on the burner panel.
- Switch on the modulating control switch.
- Switch automatic-hand switch to automatic.
- Check the temperature and pressure set values from the modulating control unit.
- Ignition will take place at the end of pre-purge process.
- 3 sec. later, the gas valve will be opened and combustion will occur.
- Flame control system (ionization) will start flame control.
- In modulating burner, the burner goes into max. capacity according to the signal from the modulating control unit.
- When the boiler water temperature or steam pressure increase, the modulating control unit will cause burner to run with min. capacity.
- If the boiler water temperature or steam pressure increases despite the operation of burner with min. capacity, the modulating control unit will stop the burner.

8.3. Combustion Adjustment

➤ Fuel nozzle

Use proper wrench in installation and dismantle of the fuel nozzle.

Use diesel oil to clean the fuel nozzle. Do not use thinner and its derivatives.

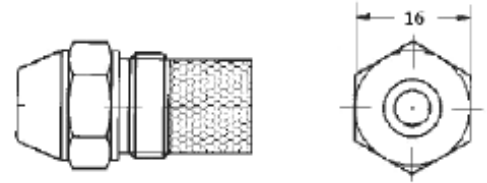

➤ Photocell

Check the photocell weekly. Clean the dust or fume stains on the glass of photocell by a dry cloth.



8.4. Fuel Pumps

AS Type

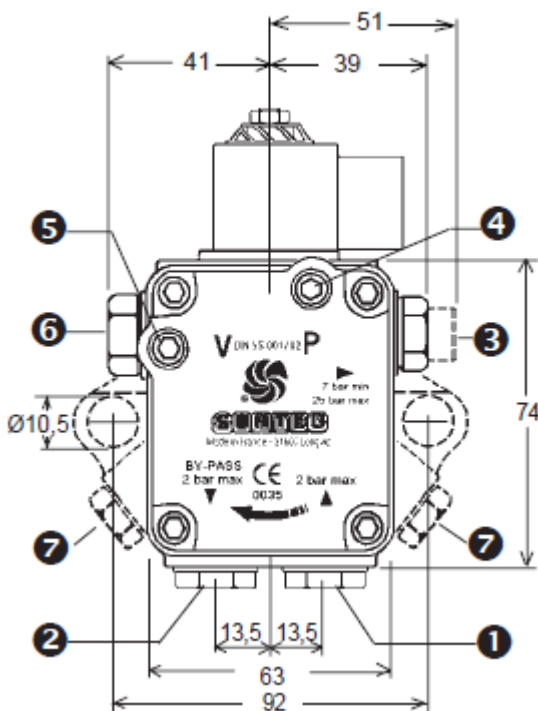

- 1- Suction
- 2- Return and internal bypass
- 3- Nozzle outlet
- 4- Manometer connection
- 5- Vacuum manometer connection
- 6- Pressure adjustment
- 7- Pressure port (in 7000 series)

D Type

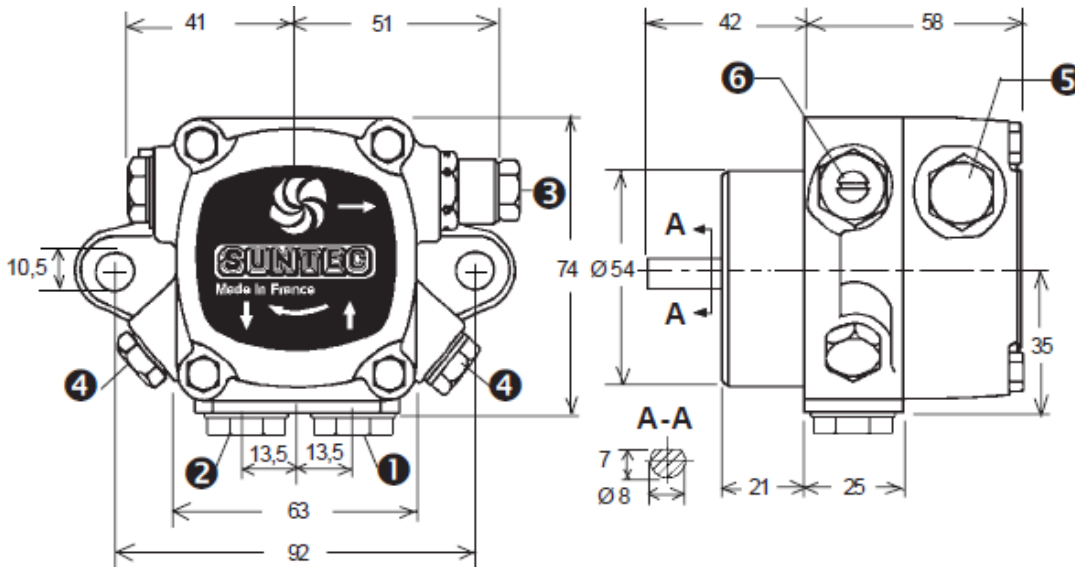

- 1- Suction
- 2- Return and internal bypass
- 3- Nozzle outlet
- 4- Manometer connection
- 5- Vacuum manometer connection
- 6- Pressure adjustment

E Type

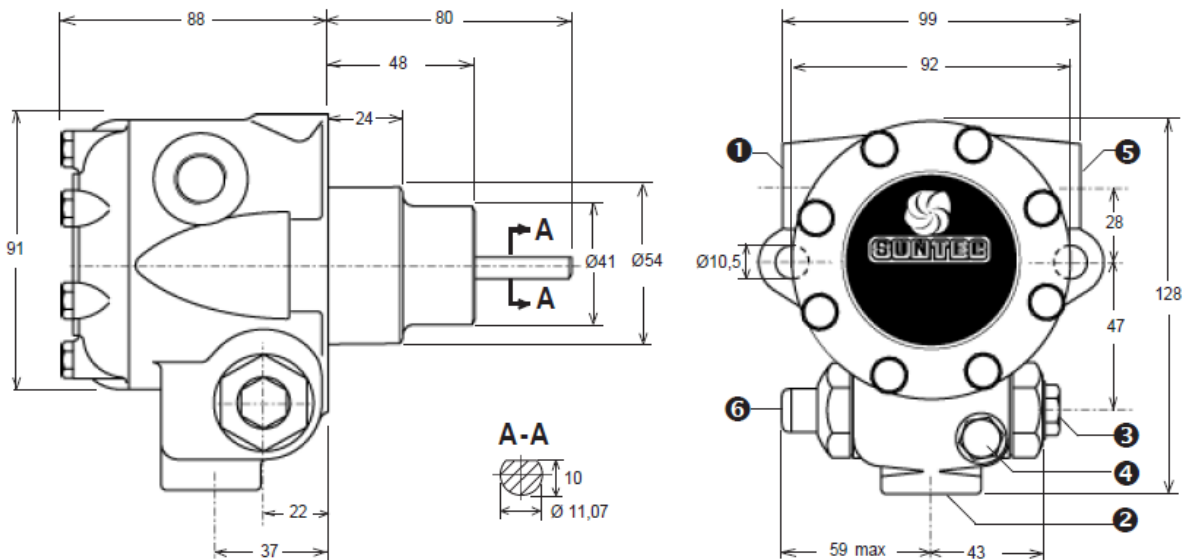

- 1- Suction or vacuum manometer connection
- 2- Return and internal bypass
- 3- Nozzle outlet
- 4- Manometer connection
- 5- Vacuum manometer connection
- 6- Pressure adjustment

➤ **One Stage Light Oil Burner Fuel Circuit**

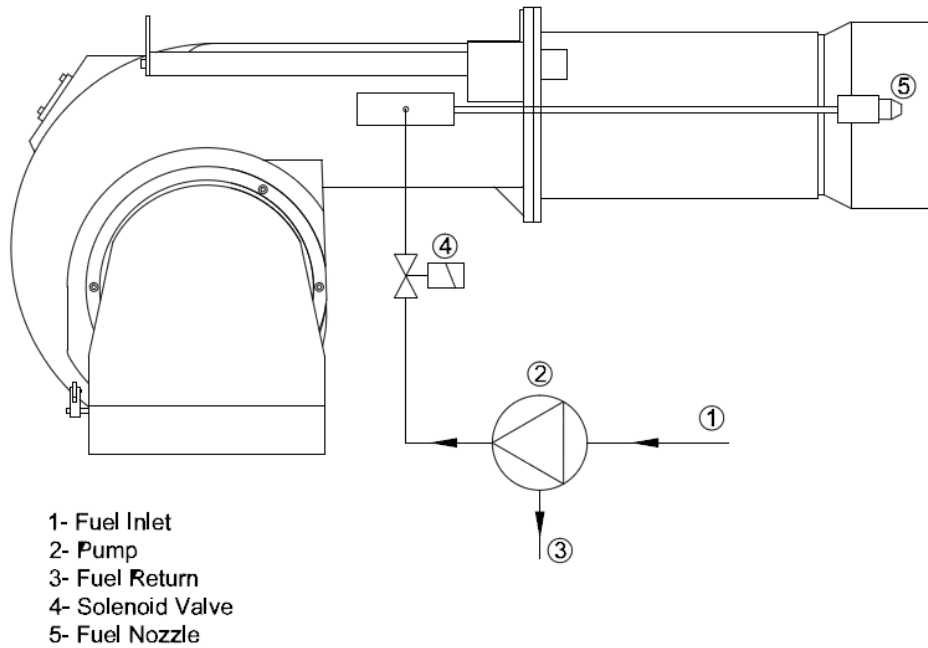

➤ **Two Stages Light Oil Burner Fuel Circuit**

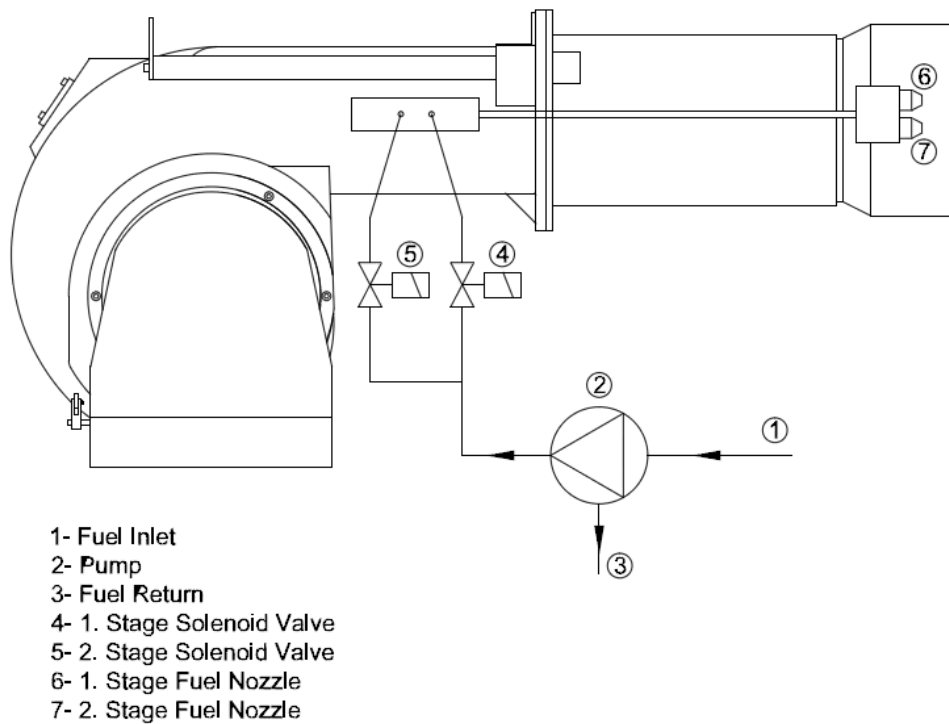

➤ **Modulating Light Oil Burner Fuel Circuit**

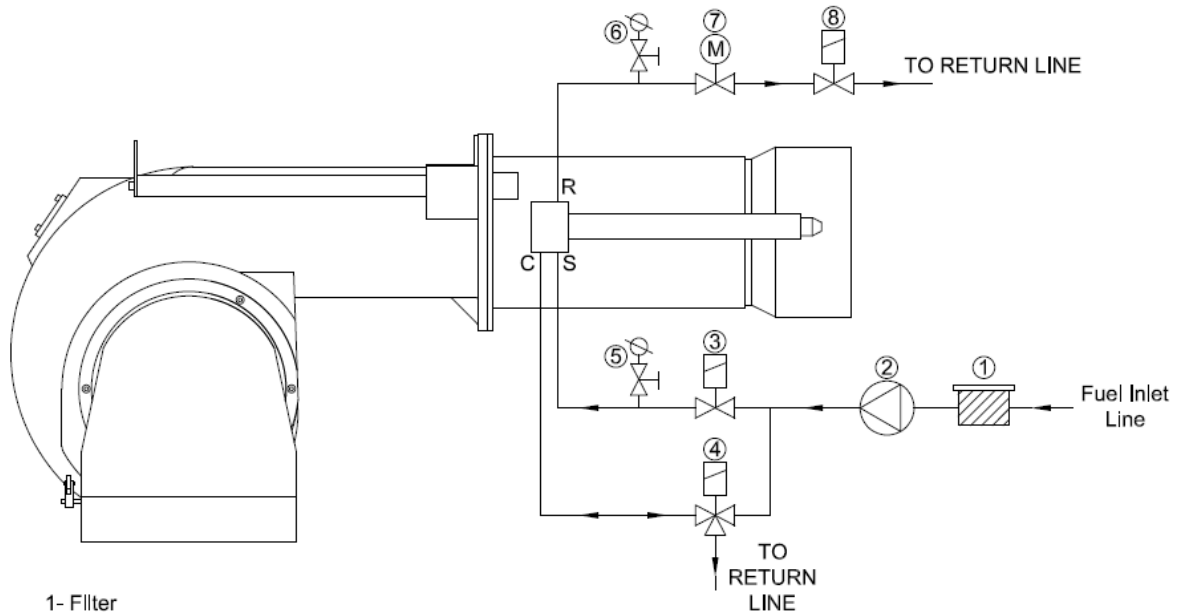

- 1- Filter
- 2- Pump
- 3- Safety Inlet Valve
- 4- Hydraulic Control Valve
- 5- Manometer
- 6- Manometer
- 7- Oil Set Valve
- 8- Safety Outlet Valve



CAUTION!

- **End of the line to the main tank must be open to the atmosphere and line pressure must be zero, otherwise no healthy modulating operation can be ensured since the pressure, which is to form in return, will also affect nozzle pressure. Fuel may drop from nozzle end during stops.**
- **For good pulverization, periodically check durability of the o-ring. In the event of earing of the o-ring, fuel to the nozzle can by-pass and go directly to the return and reduces the working performance of the nozzle.**
- **Maximum operating pressure of the nozzle is 30 bars. This value should not be exceeded during working. Even if these out of control value are exceeded, nozzle must be taken to emergency maintenance and all O-rings must be replaced.**
- **Do not use solvent based materials (thinner and derivatives) during cleaning of the fuel nozzle; clean with gas oil or diesel oil. Fuel nozzle inner kit is very sensitive and even invisible deformations can reduce working performance; dismantling-installing work must be performed only by trained personnel.**
- **Spring has lost its function if dropping from fuel nozzle or fuel exit at large scale is observed when the nozzle performs circulation. It must be checked and replaced if necessary.**
- **During fuel supply, the pressure at the burner fuel pump must be max. 0,40 +0,05 bar for light oil . When the burner is not operating or operating at the maximum fuel flow required, fuel supply pressure value should not changed in the burner pump.**

8.5. Gas Adjustment

8.5.1. VGD 20 4011 - 5011 Series Gas Valve

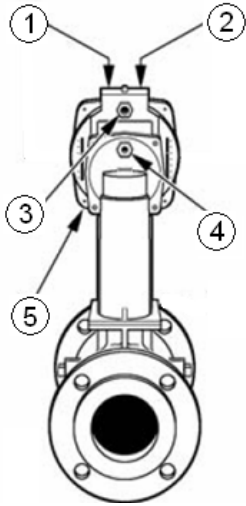

SKP 75 Connection Diagram

- 1 – Air-gas adjustment ratio
- 2 – Zero "0" point (start) adjustment
- 3 – Boiler counter pressure impulse connection
- 4 – Gas pressure impulse connection
- 5 – Air pressure impulse connection

8.5.2. MB DLE Series Monoblock Gas Valve

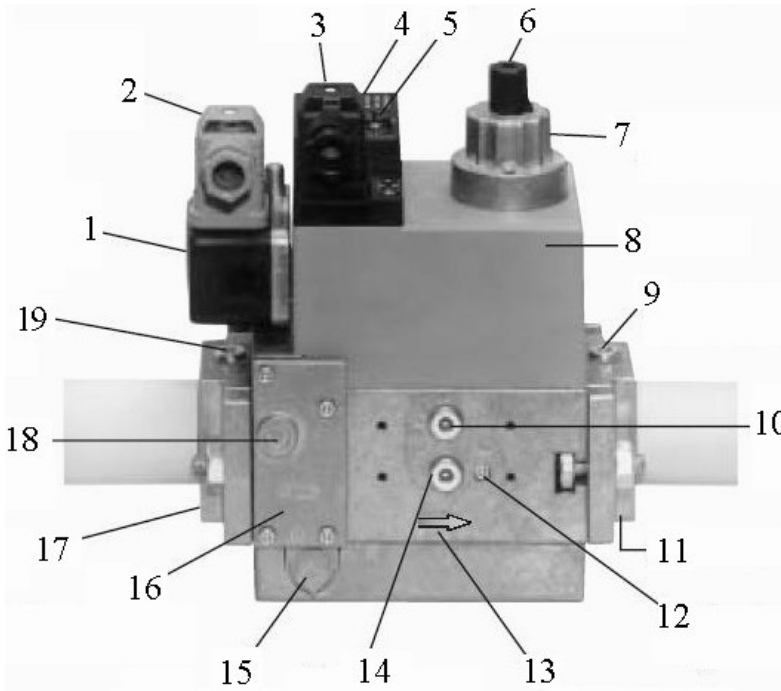

- 1- Pressure switch
- 2- Pressure switch electrical connection
- 3- Electrical connection of the valve
- 4- Operation gauge
- 5- The sealing ring
- 6- Set cover
- 7- Hydraulic disk brakes or settings
- 8- Coil
- 9- Measuring element connection (1/8)
- 10- Measuring element connection (1/8)
- 11- Output flange
- 12- Measuring element connection (1/8)
- 13- Gas flow way
- 14- Measuring element connection (1/8)
- 15- The vent plug
- 16- Filter chamber cover
- 17- Inlet flange
- 18- Measuring element connection (1/8)
- 19- Measuring element connection (1/8)

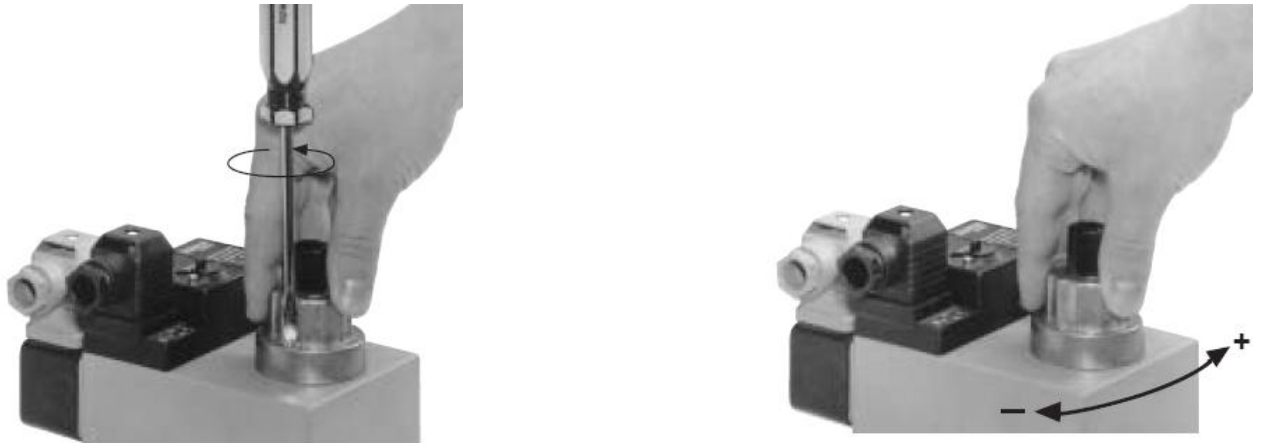

- Consider the below torque values for bolts tightened on the valve.
- Tighten flange bolts according to cross ordering and use proper tools.
- Sealing and function check must be performed if the valve is dismantled and re-installed over the line due to any reason.
- Before dismantling the valve from the line, you can perform filter replacement according to the below order.
 - o Cut off the gas flow (turn off the ball valve)
 - o Remove the 4 bolts (1,2,3,4) on the cover seen in the picture and take out the cover (5).
 - o Take the filter cartridge (6) out of its socket and replace with a new one
 - o Close the cover and tighten the bolts. In frequently performed filter replacement operations, use M4x14 bolt instead of self-tapping bolts used for fixing the cover.
 - o Perform sealing and function control

Max. torque values;

M 4	M 5	M 6	M 8	G 1/8	G 1/4	G 1/2	G 3/4
2,5 Nm	5 Nm	7 Nm	15 Nm	5 Nm	7 Nm	10 Nm	15 Nm

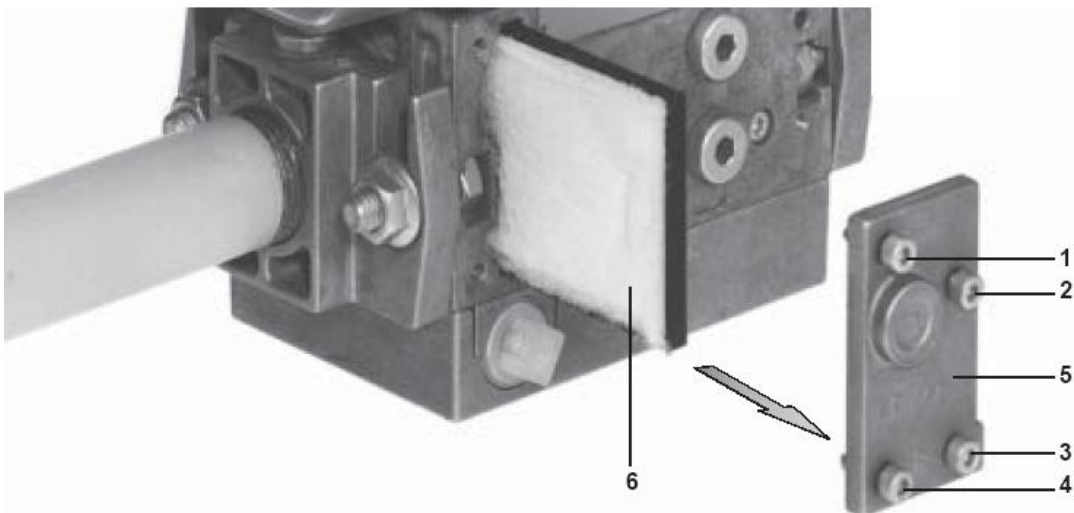

8.5.3. MB ZRD(LE) 405 – 412 Series Gas Valve

GasMultiBloc[®]

**Combined regulator and
safety shut-off valves
Two-stage function**

MB-ZRD(LE) 405 - 412 B01

DUNGS[®]
Combustion Controls

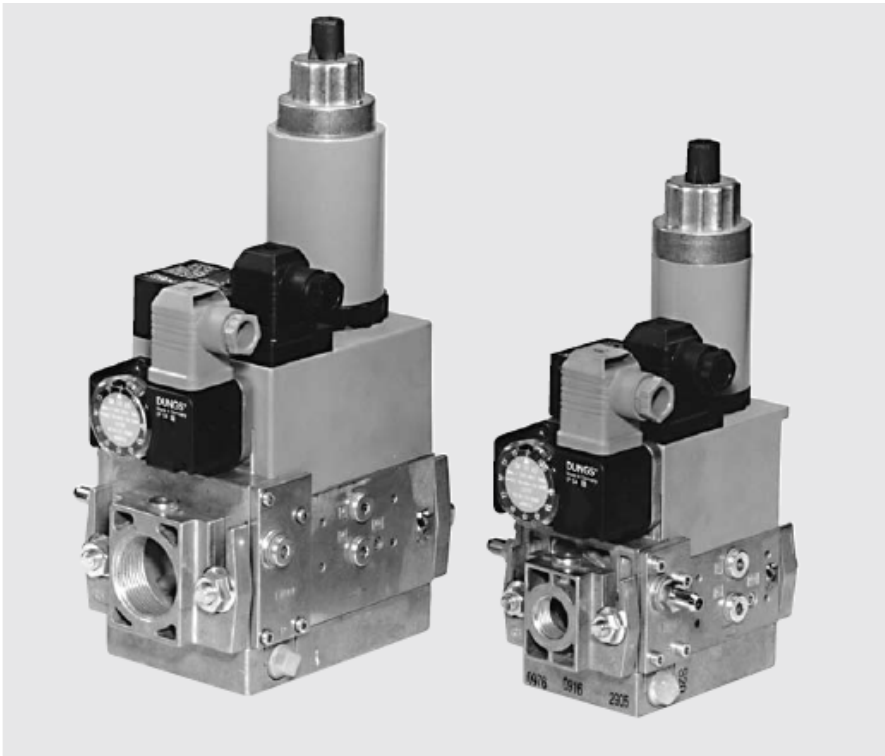

Technical description

The DUNGS GasMultiBloc[®] integrates filter, regulator, valves and pressure switches in one compact fitting.

- Dirt trap: microfilter
- One regulator and two main valves: B01
- One one-stage valve and one two-stage valve
- One valve is fast opening, one valve is slow or fast opening
- Solenoid valves up to 360 mbar (36 kPa) as per DIN EN 161 Class A Group 2
- Sensitive setting of output pressure by proportional regulator as per DIN EN 88 Class A Group 2
- High flow rates with low pressure drop
- DC solenoid drive interference degree N
- Main volume restrictor and partial volume restrictor at valve V2
- Hydraulic opening delay
- Flange connections with pipe threads as per ISO 7/1
- Simple mounting, compact, light-weight

The modular system permits individual solutions by using external ignition gas tap in connection with separately controlled valves, by adding a valve proving system, mini/maxi pressure switches, pressure limiters, limit switch and closing stroke limiter at valve V2, regulator blocking for liquid gas applications.

Application

The modular system permits individual solutions in gas safety and regulator engineering. Suitable for gases of families 1, 2, 3 and other neutral gaseous media.

Approvals

EC type test approval as per EC Gas Appliance Directive:
MB-ZR...405-412 B01 CE-0085 AP 3156
EC type test approval as per EC Pressure Equipment Directive:
MB-ZR...405-412 B01 CE0036
Approvals in other important gas consuming countries.

8.6. Air Pressure Switch Adjustment

While the burner is working without any problem, the air pressure switch is adjusted to desired minimum pressure as follows.

- Unscrew the screw of the transparent cover and remove the cover.
- Turn the adjustment wheel in the direction to increase the pressure, note the pressure value at which the burner is failed.
- Set the pressure switch to a value 1 mbar lower than the pressure value at which the burner failed and close the pressure switch lid.
- It is recommended that this adjustment is carried out when the burner is at minimum load.



8.7. Servomotor Adjustment

The amount of air is adjusted by means of the servomotor. The servomotor adjustment at two-stage and modulating burners is made by the cams on the servomotor.

- **SQN70**

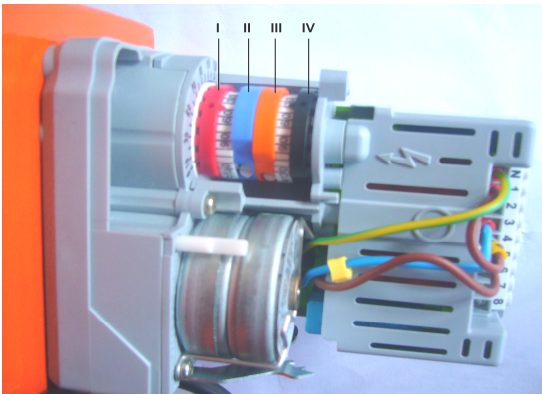

At Two-stage Burners;

- I. Red Cam: Adjusts 2nd level max. air.
- II. Blue Cam: Resets the clamp.
- III. Orange Cam: Adjusts 1st level min. air.
- IV. Black Cam: Adjusts 2nd level valve opening degree.

At Modulating Burners;

- I. Red Cam: Performance max. air adjustment.
- II. Blue Cam: Resets the clamp.
- III. Orange Cam: Performs min. air adjustment.
- IV. Black Cam: Not used.



Do not open servomotor. Do not interfere with. It may damage servomotor or change burner settings.

8.8. Emission Measurement

In emission measurements, the following values are accepted as reference according to TS EN 676 +A2 standard.

- CO < 100 mg/ kWh
- %3 ≤ O₂ ≤ %5
- NO_x < 170 mg/ kWh
- Excess air ratio 1,2 ≤ λ ≤ 1,3

In emission measurements, the following values are accepted as reference according to TS EN 267 standard.

- CO < 110 mg/ kWh
- %3 ≤ O₂ ≤ %5
- NO_x < 250 mg/ kWh
- Excess air ratio 1,2 ≤ λ ≤ 1,3



It is important for the boiler to be sealed in order to avoid incorrect measurements during emission measurements.



Boiler temperature must be between 40 C° and 80 C° while making emission measurement in hot water boilers.

8.9. Program Relay

LFL 1.32



LME 22



- Yellow led on: Indicates that the burner is making pre-purge.
- Yellow led flashing: Indicates that the burner is igniting.
- Green led flashing: Indicates poor combustion.
- Red led on: Indicates burner malfunction.



Press and hold the light button for 2 sec. to reset the program relay.



If the value measure from PL point is below 0.5 bar, set the impulse pipe as follows.

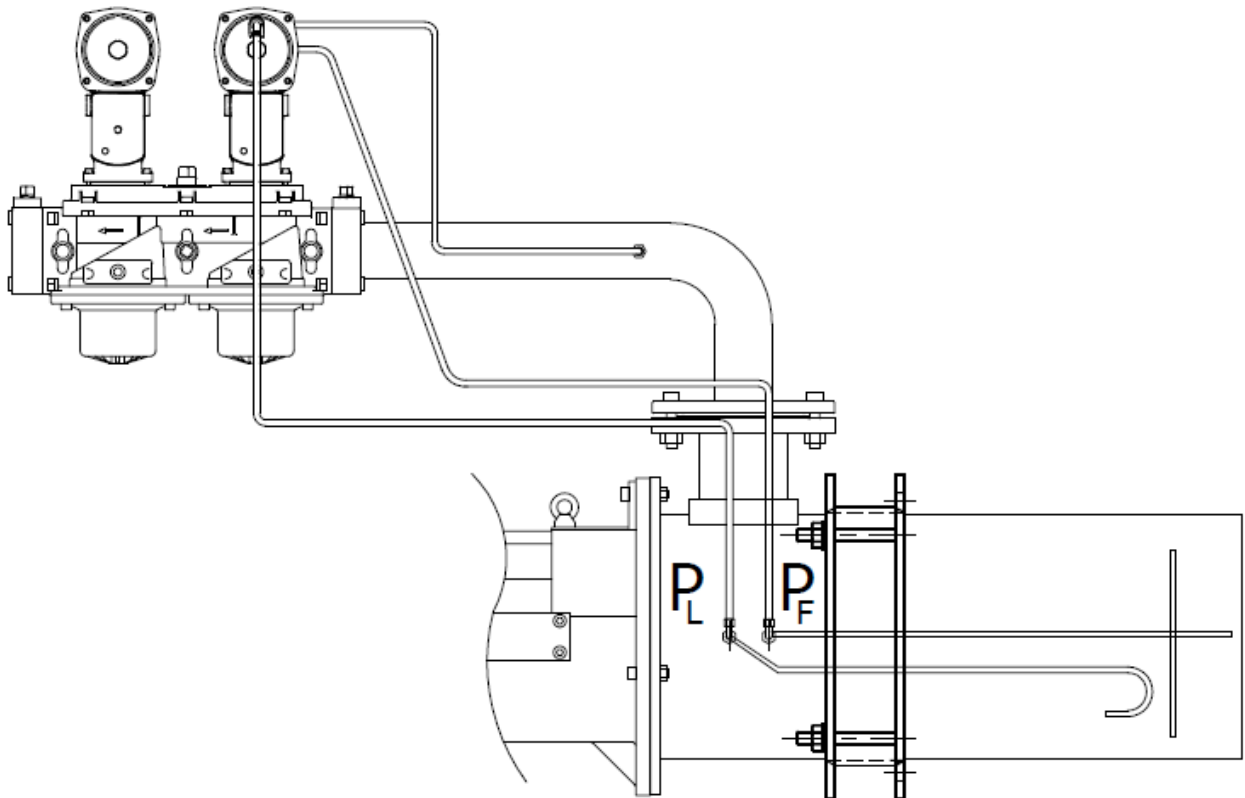
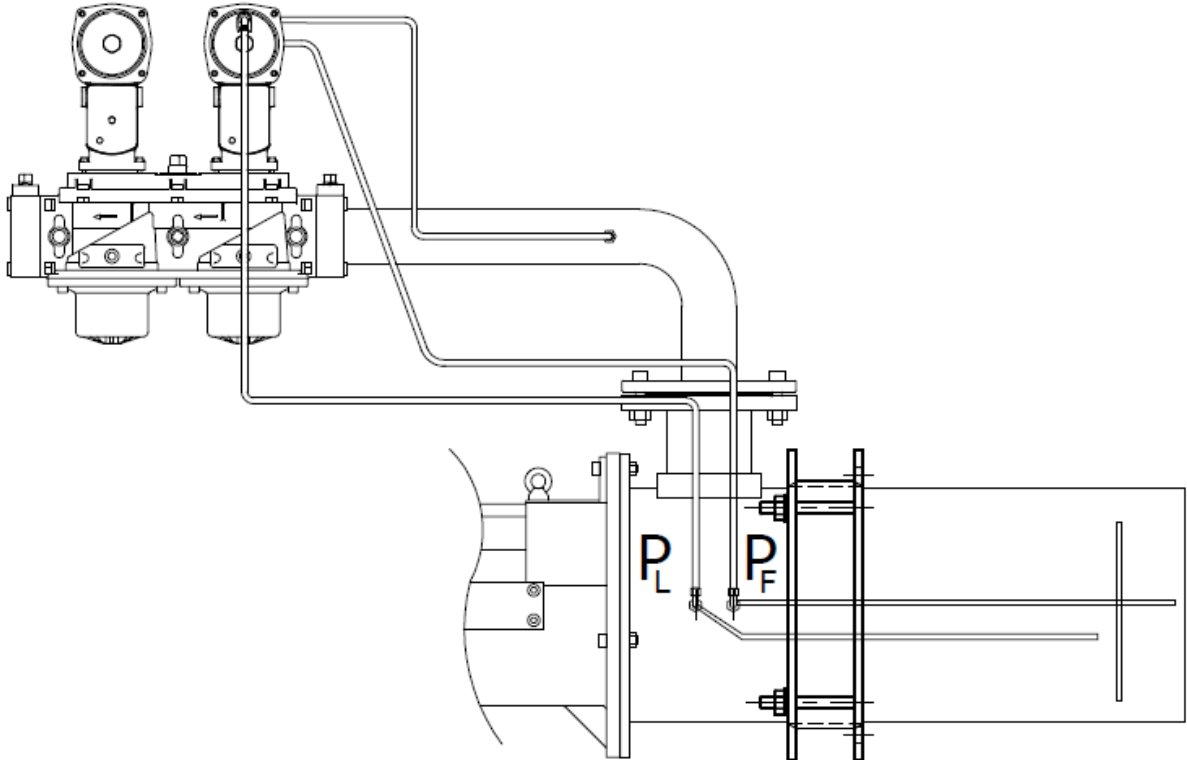



If the flame tube of the burner is longer than standard (standard flame tube length of the burner), please do not forget to support burner body during maintenance and installation/commissioning.

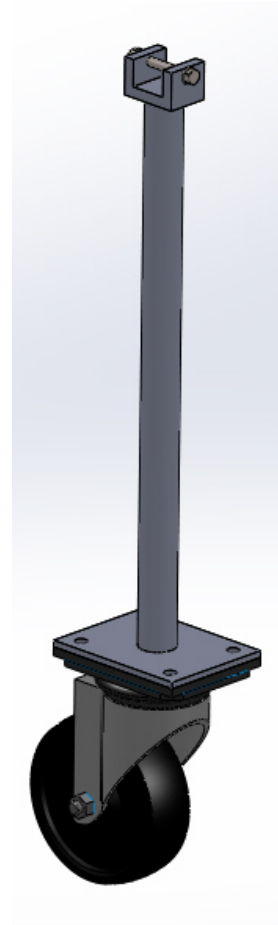
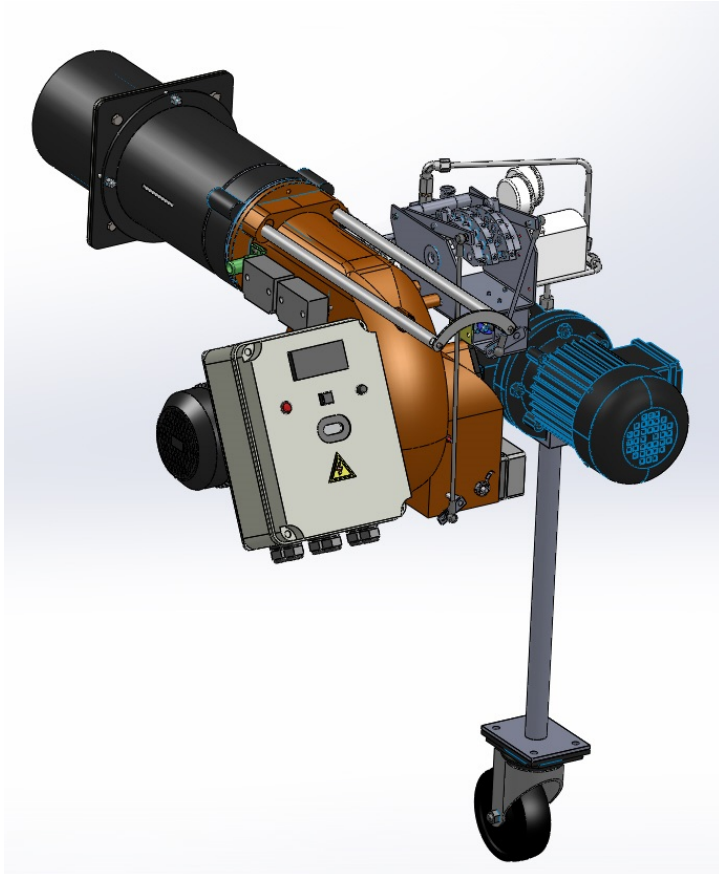

8.10. Light Oil Burner Fuel Ring Line

Tank is above the burner level.

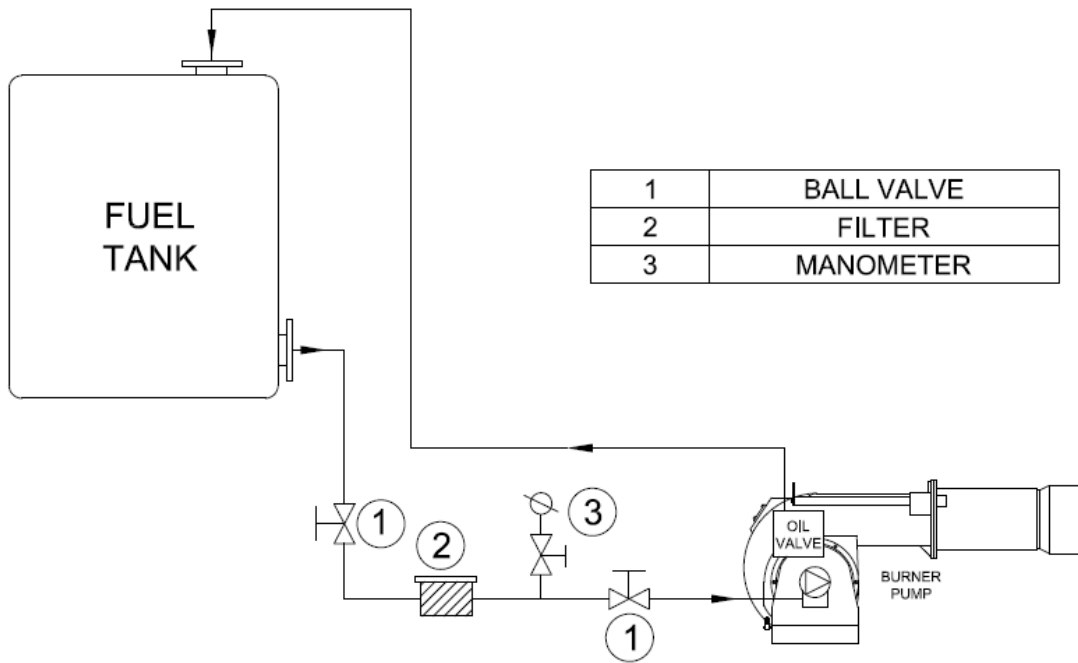

Tank is below the burner level.

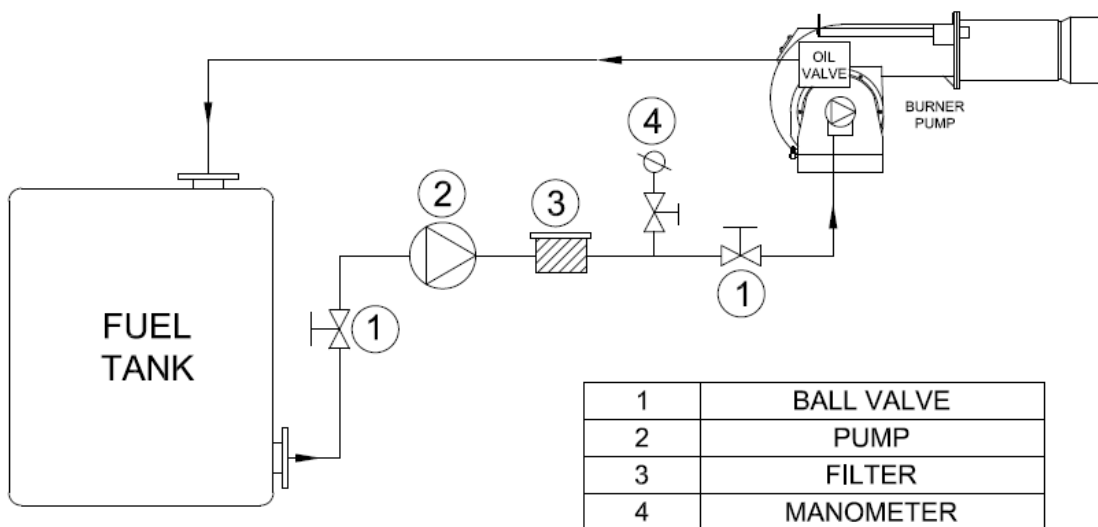

8.11. Gas Pass Equipment Required in Gas Line

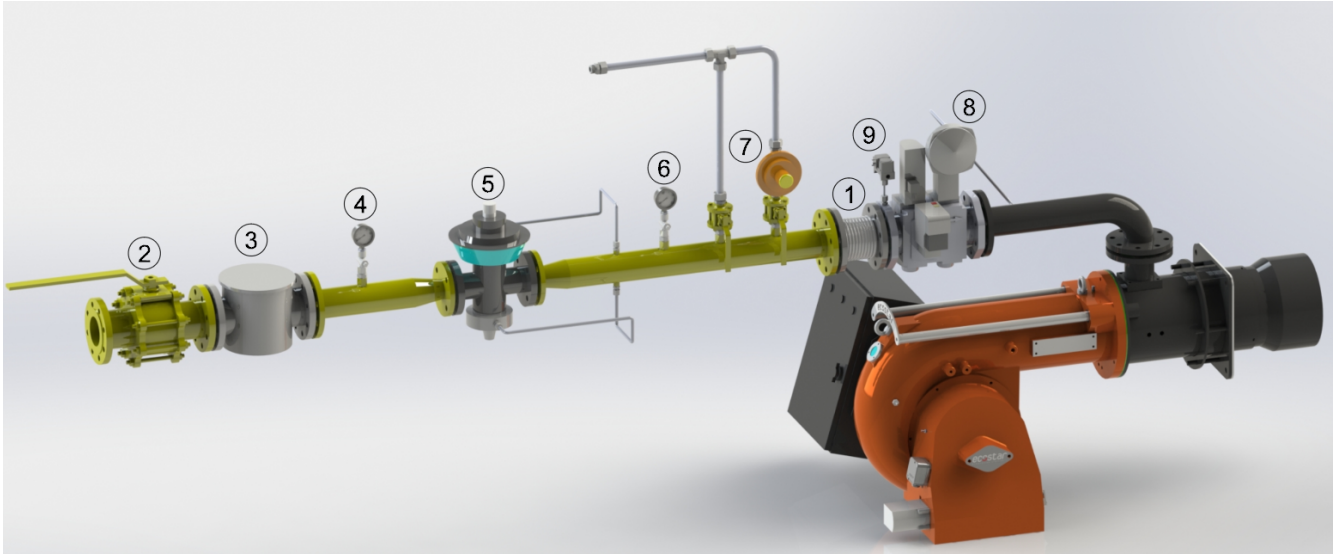

Pe < 300 mbar Q<1200kW	Pe > 300 mbar Q<1200kW	Pe < 300 mbar Q>1200kW	Pe > 300 mbar Q>1200kW
1- Compensator	1- Compensator	1- Compensator	1- Compensator
2- Ball valve	2- Ball valve	2- Ball valve	2- Ball valve
3- Gas filter	3- Gas filter	3- Gas filter	3- Gas filter
4- Inlet manometer + valve	4- Inlet manometer + valve	4- Inlet manometer + valve	4- Inlet manometer + valve
8 – Multi-block (safety and operation solenoids)	5- Regulator	8 – Multi-block (safety and operation solenoids))	5- Regulator
9- Sealing Control Set	6- Outlet manometer + valve	9- Sealing Control Set	6- Outlet manometer + valve
	7- Safety discharge valve		7- Safety discharge valve
	8 – Multi-block (safety and operation solenoids)		8 – Multi-block (safety and operation solenoids)
	9- Sealing Control Set		9- Sealing Control Set



Threaded and flanged connections may vary depending on the gas pressure and consumption.

9. MAINTENANCE

9.1. Weekly Maintenance

Weekly maintenance is a routine cleaning and adjustment procedure which is performed to ensure smooth and continuous operation of the system. Burner components must be adjusted after each maintenance work in accordance with the instructions. Otherwise, the burner cannot be operated efficiently.

- Clean all filters in fuel ring system.
- Clean fuel nozzle of the burner.
- If the fin spaces and surface of the diffuser are covered with particles and formed a layer, clean it with a wire brush.
- Clean heads of ignition electrodes. Check by performing manual ignition, adjust the distance between the ignition electrode and diffuser according to the adjustment instructions.

9.2. Monthly Maintenance

Monthly maintenance is a more comprehensive maintenance compared to weekly maintenance, where general checks of burner and peripheral components are performed to prevent possible faults. After completion of maintenance and adjustment processes, make sure to perform a combustion analysis.

- Clean the filters on the fuel line to the burner.
- Clean fuel nozzle of the burner.
- Clean the surface of the diffuser.
- Clean flame pipe.
- Check all wiring points. Tighten loose connections.
- Clean the solenoid valves.
- Clean the photocell.
- Clean the dust and layers accumulated on the fan and air valves.
- Check pump pressure. Check if necessary (Light-Oil: 14 bar)
- Check ignition electrodes. Adjust it if necessary. Check ignition cables and sockets.
- Perform cleanliness control of inside panel. Clean if necessary.
- Check all bolts of the burner. Tighten loose bolts.
- Clean the filters on the main line and multiblock.
- Check the burner gas tip.
- Check gas line pressure, it must be the same with the first adjusted pressure, otherwise burner load and emission values will also have changed.
- After starting the burner and adjusting air klappe, perform flue gas analysis and check if there is an ideal combustion.

9.3. Seasonal Maintenance

Comprehensive maintenance work when the burner is re-started after long periods of shut-down or interruptions. After completion of maintenance and adjustment processes, make sure to perform a combustion analysis.

- Check insulation resistance of electric motor.
- Make surface cleaning of ignition electrodes and porcelains. Replace cracked or broken porcelains.
- Clean air fan and clamps.
- Check the operating function.
- Check cleanliness of the nozzle. Replace it if necessary.
- Clean the N.C. solenoid valve. Measure the coil winding resistance.
- Clean the strainer (filter) under the pump cover.
- Clean the photocell.
- Clean fuel filter. Replace it if necessary.
- Check boiler thermostats.
- Check cleanliness of boiler inside and clean if necessary.

10. TROUBLESHOOTING

Problem	Cause	Explanation-Suggestion
Burner cannot be commissioned	Light Oil or Gas is cut or does not come	Light Oil or Gas valve might be closed. Open the valve.
	Fuse failure	Check burner power supply. The fuse on the main panel or the fuse on the burner might be tripped.
	Relay failure	Reset the thermal relay. Check adjustment of the thermal relay according to the current in motor label. If the failure is not removed, replace the thermal relay.
	Boiler thermostat, pressure switch failure	If there is a problem with the burner thermostats, pressure switches and steam tank this may be due to an unadjusted or faulty water level device; adjust it and if broken, replace it.
Flame appears and goes into failure mode.	Light Oil or Gas pressure error	Circuit light oil or gas pressure might have dropped.
	Photocell failure	Photocell may be faulty or contaminated. Remove and clean..
	Program relay failure	Replace it with a new one.
Burner starts up, but fails after 10 seconds.	Program relay failure	Replace it with a new one.
	Air pressure switch adjustment	Air pressure switch might be adjusted to a high value. There may be dirt in the air pressure switch. Air pressure switch might be broken.
	Fan motor failure	Check fan motor coils, motor contactor and outlet from program relay.
Burner starts up, but fails after 30 seconds.	Light Oil or Gas valve, light oil or gas pressure drop	Light Oil or Gas valve might be closed. Circuit fuel oil or gas pressure might have dropped. Check Light Oil or Gas inlet manometer.
	Ignition electrode failure	Ignition electrodes might be misadjusted or ignition cables might have come out of their terminals. Adjust ignition electrodes with a distance of 3-5 mm. between them.
Boiler cover is overheating.	Sealing problem	Ensure sealing between the boiler cover and burner. If required, use insulating material between the boiler connecting flange and boiler cover.

11. PERIODICAL FLUE GAS MEASUREMENT REPORT									
Fuel Consumption (kg/h)	Fuel Consumption (m³/h)	CO (ppm)	O₂ (%)	CO₂ (ppm)	NO_x (ppm)	Yield (%)	Flue Temp. (°C)	Date	Signature

12. AFTER SALES SERVICES

Dear Customer,

We believe that providing a good service is as important as providing a good product. Therefore, we continue offering wide range of comprehensive services to our conscious customers.

For your suggestions, complaints and service requests

Esentepe Mah. Milangaz Cad. No:75 K:3

Kartal Monumento Plaza

KARTAL/İSTANBUL/TÜRKİYE

Tel: 444 8 326

Fax: +90 216 370 45 03

Factory Contact Details

Türkgücü OSB

Bülent Ecevit Bulvarı No:11

ÇORLU/TEKİRDAĞ/TÜRKİYE

Tel: +90 282 685 44 80-81

Fax: +90 282 685 42 09

Also you can contact with us:

Web site : www.ecostar.com.tr

E - mail : servis@ecostar.com.tr



Please observe the following recommendations.

- Use the product in accordance with the principles of this manual.
- For any service demands regarding the product, please contact our Service Center from the abovementioned phone numbers.
- Upon your purchase, register your warranty certificate during installation.

