

MONOBLOCK HEAVY OIL BURNERS INSTALLATION, OPERATING AND MAINTENANCE MANUAL

MODULATING OPERATION

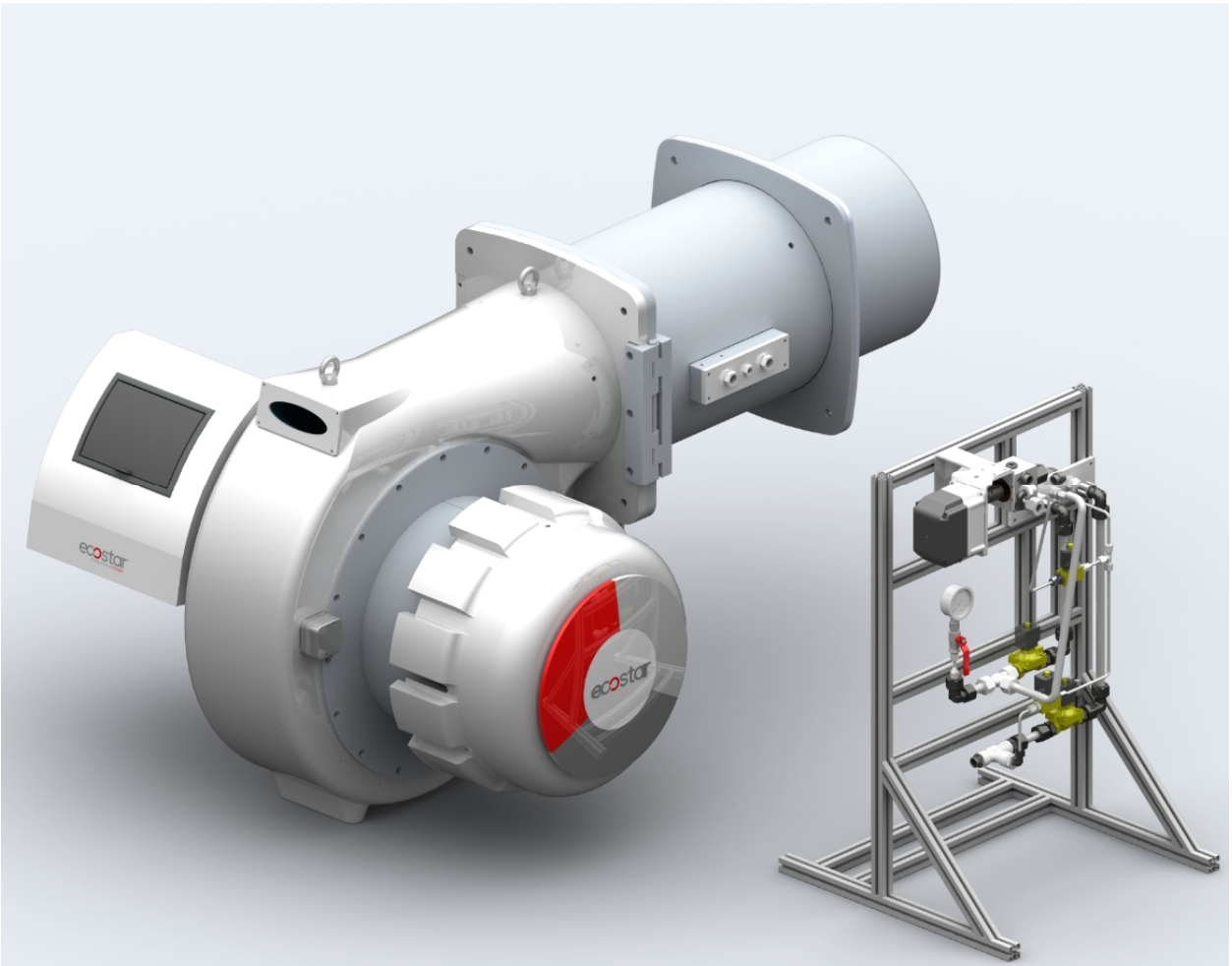

ECO 8 NG
ECO 8,5 NG
ECO 9 NG



DEAR USER,

ECOSTAR **ECO 8 NG, ECO 8,5 NG, ECO 9 NG Heavy Oil** burners are prepared and manufactured according to the latest technical developments and safety rules. It is easy to use for our customers.

We recommend that you read this manual and safety warnings thoroughly before the use of the device in order to ensure safe, cost effective and environmental-friendly use.

If you encounter any issue that is not explained clearly in this manual or you could not understand, please contact with our service department.

We thank you for choosing ECOSTAR brand.

This Operating Manual is an integral part of the burner and must be maintained in a plastic dossier and hung at a clearly visible place in the burner room.



TERMO ISI SİSTEMLERİ SAN.VE TİC.A.Ş.

Esentepe Mah.Milangaz Cad. No:75 K:3

Kartal Monumento Plaza

Kartal/İSTANBUL/TÜRKİYE

Tel: +90 216 442 93 00

Fax: +90 216 370 45 03

www.ecostar.com.tr





[e-mail: servis@ecostar.com.tr](mailto:servis@ecostar.com.tr)

CONTENTS

| | |
|---|----|
| 1. WARNINGS..... | 3 |
| 1.1. Warning Symbols and Descriptions..... | 3 |
| 1.2. General Safety Rules..... | 4 |
| 2. TERMS OF WARRANTY..... | 6 |
| 2.1. Out of Warranty Conditions..... | 6 |
| 3. BURNER’S GENERAL FEATURES..... | 7 |
| 3.1. Purpose of Use and Work Limits of Burners..... | 7 |
| 3.2. Code Key..... | 7 |
| 4. FLUE GAS AND HEATING WATER SCHEMA..... | 9 |
| 5. TECHNICAL DATA..... | 10 |
| 5.1. Capacity and Technical Chart..... | 10 |
| 5.2. Back Pressure-Capacity Diagrams..... | 11 |
| 5.3. Outer Dimensions..... | 13 |
| 5.4. Flame Length and Diameter..... | 14 |
| 6. INSTALLATION..... | 15 |
| 6.1. Burner Installation Picture..... | 15 |
| 7. COMMISSIONING..... | 16 |
| 7.1. General Controls..... | 16 |
| 7.2. Combustion Adjustment..... | 17 |
| 7.3. Fuel Pumps..... | 17 |
| 7.5.BT 300..... | 27 |
| 7.5.1.Operating Control and Displays..... | 28 |
| 7.5.2. Menu Functions..... | 29 |
| 7.5.3. BT300 Connecting Diagram..... | 30 |
| 7.6. Servomotor..... | 31 |
| 7.7. Function Controls and Adjustments..... | 32 |
| 7.8. Final Checks..... | 32 |
| 7.9. Pilot Ignition System..... | 35 |
| 7.10. Emission Measurement..... | 35 |
| 7.11. Heavy Oil Burner Fuel Ring Line..... | 36 |
| 8. MAINTENANCE..... | 37 |
| 8.1. Weekly Maintenance..... | 37 |
| 8.2. Monthly Maintenance..... | 37 |
| 8.3. Seasonal Maintenance..... | 38 |
| 9. FAULT HISTORY..... | 39 |
| 10. PERIODICAL FLUE GAS MEASUREMENT REPORT..... | 40 |
| 11. AFTER SALES SERVICES..... | 41 |
| 12. NOTES..... | 42 |

1. WARNINGS

1.1. Warning Symbols and Descriptions

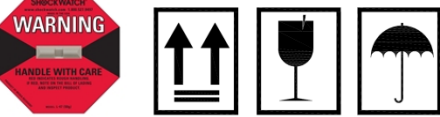
| Symbols | Symbol Descriptions |
|---|--|
|  | Important information and useful hints. |
|  | Warning of danger to life or property. |
|  | Warning of electrical voltage. |
|  | Product handling information. |
|  | Electric motor direction of rotation |
|  | Carry in an upright position. Fragile Item. Protect against water. |

1.2. General Safety Rules

- All personnel engaged in installation, disassembly, commissioning, operation, control, maintenance and repair should have received the necessary training, qualified and fully read and understood this manual.
- No changes that might damage the safety of the burner unit must be made by persons and/or organizations on the burner unit.
- All operation, commissioning and installation works (except for burning adjustment) should be carried out when the burner is not operating and after disconnecting the power supply. Noncompliance with these rules may lead to serious bodily injuries and even death by electrical shocks or uncontrolled flame formation.
- Repairs concerned with safety elements should be carried out only by the manufacturing company.
- The device should never be used by children, mentally handicapped and inexperienced persons.
- Children must not be allowed to play with the device.
- Keep the device away from explosive and flammable materials.
- Device must intake air, ventilation and air discharge holes must not be closed.



Do not store any inflammable materials in boiler room.



Wear hearing protectors if there is noise in boiler room.



In case of fire or other emergency;

- Switch off the main switch
- Take appropriate actions



The burner installation must be carried out in accordance with the instructions. Vibration can damage the burner and its components.



Keep boiler doors closed while starting burner and during burner operation.



Check combustion values to be correct by using flue gas analysis at the whole adjustment range between minimum, full load, and ignition load.



Use lifting device or belt for lifting fan motor, if necessary



During the first commissioning of the burner or in case of any revision carried out in the electrical system or motor cables by any reason, direction of the fan rotation must certainly be checked by the authorized technical service.



For products that have not been commissioned or started more than 6 months, before activating the servomotor;

In air dampers and oil regulators, servomotor and air damper connections must be checked to ensure that they are free running in spite of immobility and oil freezing.



BURNER ROOM

Install the burner in a suitable room/floor with minimum external air openings and sufficient to ensure perfect combustion, in compliance with current regulations.

Never obstruct air openings of the burner room, burner fan intake vents or air ducts in order to prevent:

- a. The build up of toxic / explosive gas mixtures in the burner room,
- b. Combustion with insufficient air, resulting in hazardous, anti-economical and polluting operation.

The burner must be always protected from rain, snow and frost to prevent corrosion and paint deformations.

Keep the burner room clean and free of solid volatile substances, which could be sucked into the fan and clog the internal burner or combustion head air ducts.

2. TERMS OF WARRANTY

Main and auxiliary equipment and all components used in Ecostar Heavy Oil burners are guaranteed for 1 year by TERMO ISI SİST. A.Ş starting from the date of commissioning under the maintenance, adjustment, operating conditions and relevant mechanic, chemical and thermal effects explained herein.



Please note that this warranty is only valid if the device(s) is commissioned and maintained by our authorized services.



Our company reserves the right to make any modifications on the product and all instructions thereof for improvement purposes.

2.1. Out of Warranty Conditions

- Any damage arising out of or in relation to customers' non-compliance to their responsibilities with regards to installation, commissioning, operation and maintenance,
- Any damage arising out of or in relation to commissioning, repairs and maintenance carried out by unauthorized services,
- Any damage that may occur during transportation or storage of the product,
- Not preserving the product in its original packaging until the installation stage,
- Incorrect and poor electrical connections, Failures due to incorrect voltage applications, frequent repetition of voltage fluctuations,
- Any damage that may occur as a result of incorrect fuel usage or, foreign substances in the fuel used or using of the product without any fuel,
- Any damage that may occur due to foreign particles entered into the product during installation and operation,
- Failures due to incorrect device selection,
- Any damage to unit due to natural disasters,
- Devices without any warranty certificates,
- Warranty Certificates without the stamp and signature of the authorized dealer or service,
- Devices with any falsification on the warranty certificate or without an original serial number.
- The risks during transportation of device under the responsibility of customer belong to the customer.
- Presence of misuse faults are indicated in the reports issued by authorized service stations or our authorized agent, dealer, representative or our factory in case of unavailability of authorized service stations.
- Customers may apply consumer protection arbitrator committee with regards to this report and request for an expert report.

3. BURNER'S GENERAL FEATURES

ECOSTAR Heavy Oil burners are designed to operate with oil at 2.5 – 20 Cst (mm²/s) viscosity, at rated capacity and pressure ranges and -15% to +10% nominal voltage.

3.1. Purpose of Use and Work Limits of Burners

- This product works at any load value equivalent to its max. capacity or covered by its capacity range;
 - In hot water and steam boilers,
 - In direct and indirect hot air generators,
 - Industrial appliances operating at temperature below 600 °C,
 - -15 °C...+60 °C ambient temperature range,
 - 1N 230 VAC/3N 380VAC /50 Hz feed voltage (-%15...+%10) values,
 - Max. 95% relative humidity,
 - In well-ventilated open and closed spaces compatible with protection class IP 40.



This device must never be operated with open flame!

3.2. Code Key

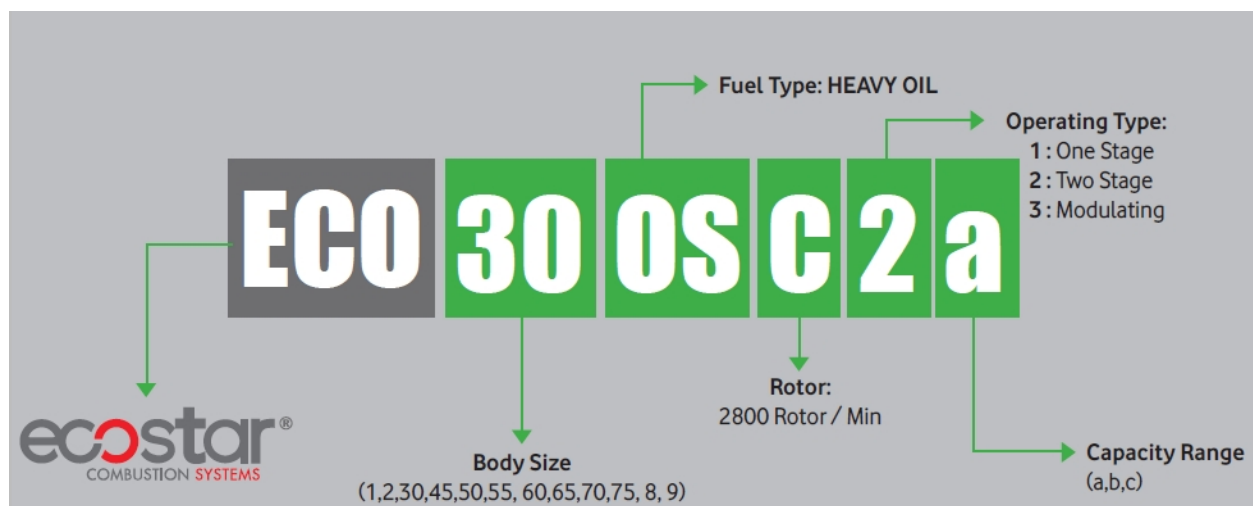

c St

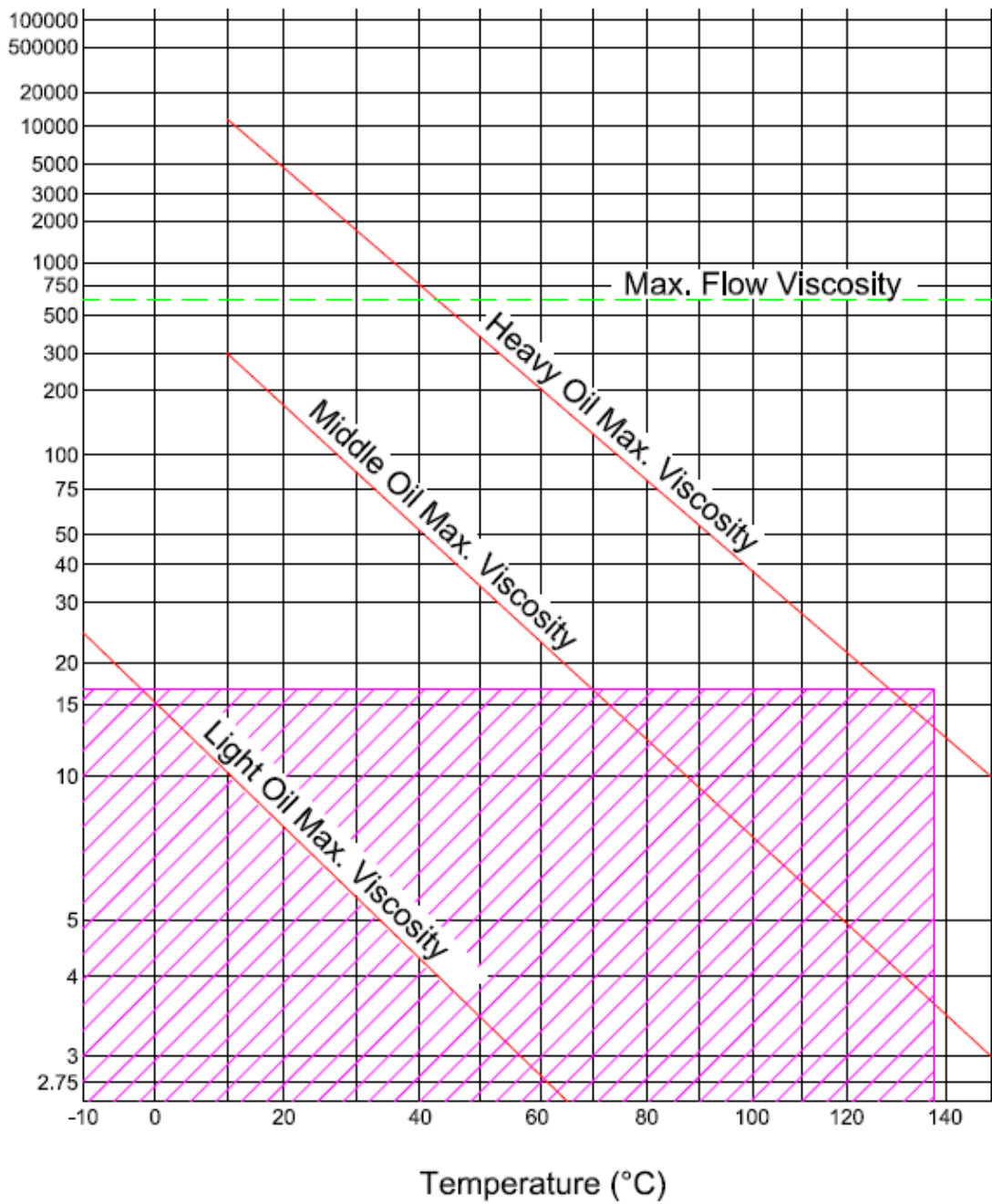

Temperature change of fuel used in ECOSTAR heavy oil burners dependent on viscosity



Operating Range

4. FLUE GAS AND HEATING WATER SCHEMA

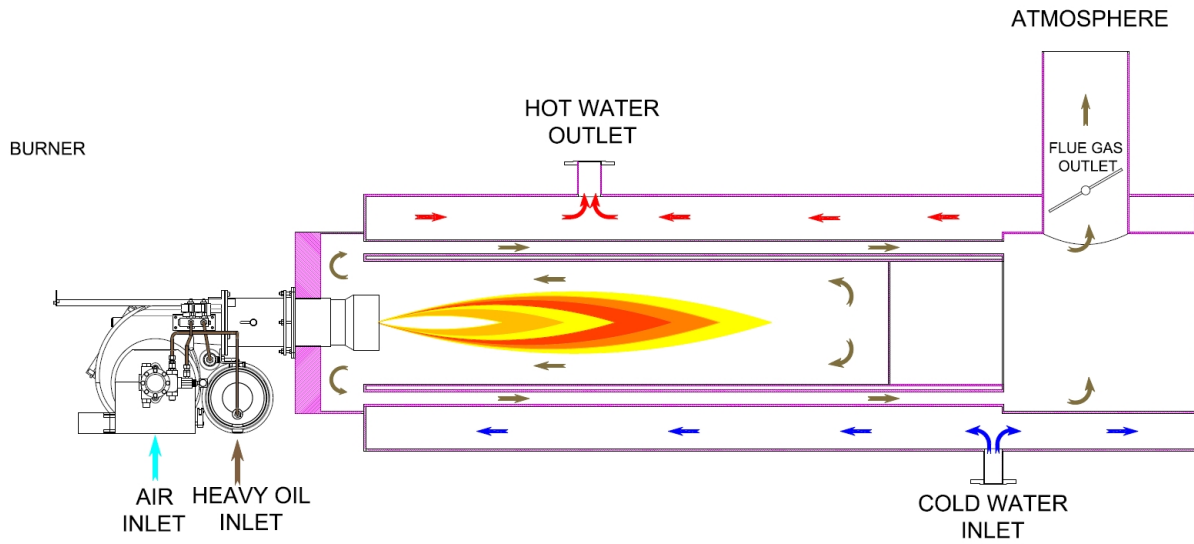

5. TECHNICAL DATA

5.1. Capacity and Technical Chart

| NEW GENERATION MODULATING HEAVY-OIL BURNERS CAPACITY TABLE | | | | | | | | | | |
|--|-------------|-------------|----------|---------|-----------------------|-----------|-----------------|-----------------|-------------|-------------|
| BURNER TYPE | CAPACITY | | CAPACITY | | HEAVY OIL CONSUMPTION | | FAN MOTOR POWER | FUEL PUMP POWER | FUEL HEATER | MAIN SUPPLY |
| | Min. kcal/h | Max. kcal/h | Min. kW | Max. kW | Min. kg/h | Max. kg/h | kW | kW | kW | VAC |
| ECO 8 O (S) C 3 NG | 722.400 | 5.160.000 | 840 | 6000 | 74,9 | 534,7 | 11 | 2,2 | 2 x 14,0 | 3N 400 |
| ECO 8 O (S) C 3 a NG | 842.800 | 6.020.000 | 980 | 7000 | 87,3 | 623,8 | 11 | 2,2 | 2 x 16,0 | 3N 400 |
| ECO 8 O (S) C 3 b NG | 963.200 | 6.880.000 | 1120 | 8000 | 99,8 | 713,0 | 15 | 2,2 | 2 x 16,0 | 3N 400 |
| ECO 8.5 O (S) C 3 NG | 851.400 | 6.235.000 | 990 | 7250 | 88,2 | 646,1 | 18,5 | 3 | 37 | 3N 400 |
| ECO 8.5 O (S) C 3a NG | 963.200 | 6.880.000 | 1120 | 8000 | 99,8 | 713,0 | 22 | 3 | 37 | 3N 400 |
| ECO 8.5 O (S) C 3b NG | 1.143.800 | 7.955.000 | 1330 | 9250 | 118,5 | 824,4 | 22 | 3 | 37 | 3N 400 |
| ECO 9 O (S) C 3 NG | 1.023.400 | 7.310.000 | 1190 | 8500 | 106,1 | 757,5 | 18,5 | 4 | 37 | 3N 400 |
| ECO 9 O (S) C 3a NG | 1.083.600 | 7.740.000 | 1260 | 9000 | 112,3 | 802,1 | 22 | 4 | 37 | 3N 400 |
| ECO 9 O (S) C 3b NG | 1.324.400 | 9.030.000 | 1540 | 10500 | 137,2 | 935,8 | 22 | 4 | 37 | 3N 400 |
| ECO 9 O (S) C 3c NG | 1.806.000 | 10.320.000 | 2100 | 12000 | 187,2 | 1069,4 | 22 | 4 | 37 | 3N 400 |

H_u Heavy Oil (S) = 9650 Kcal/kg

5.2. Back Pressure-Capacity Diagrams

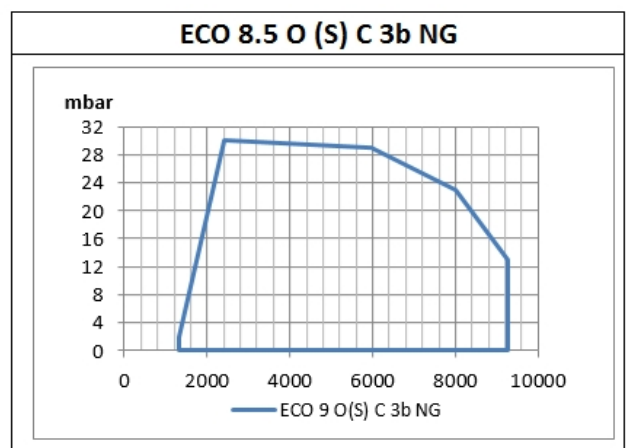
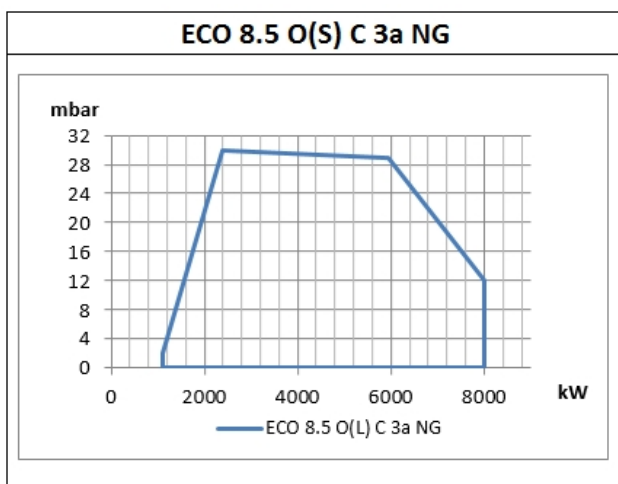
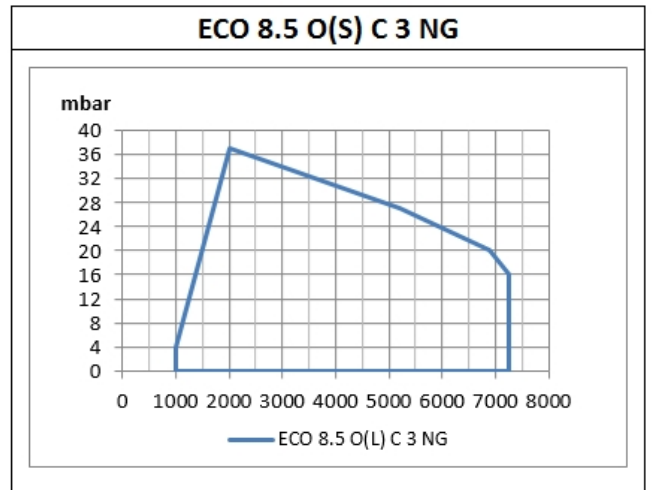
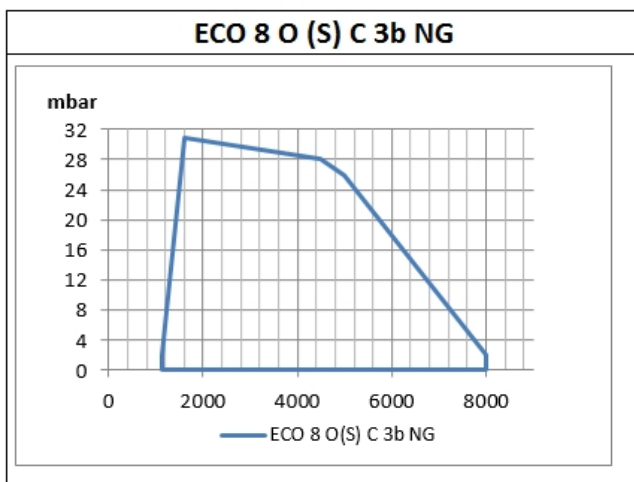
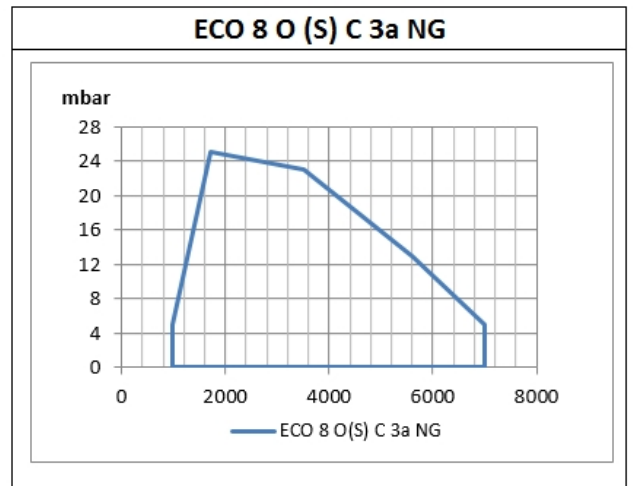
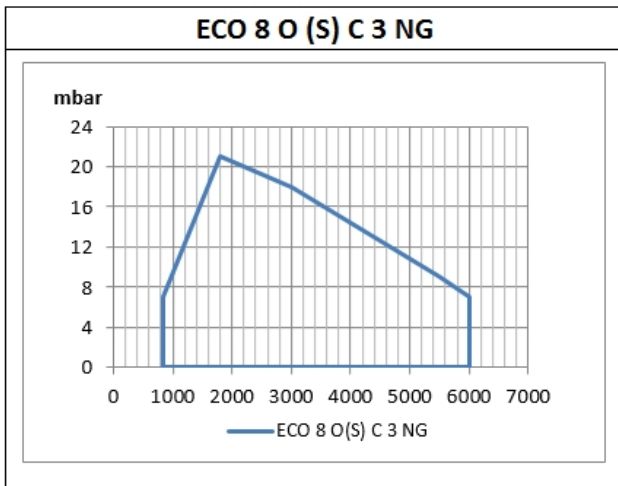

ECO 9 O (S) C 3 NG

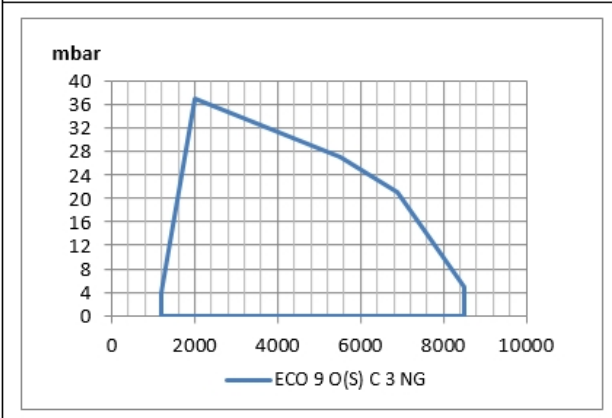

ECO 9 O (S) C 3a NG

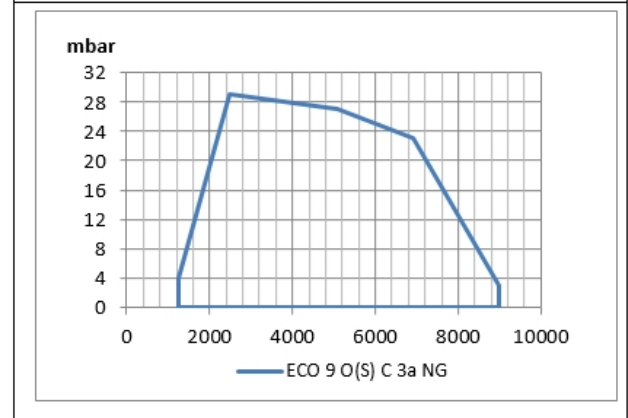

ECO 9 O (S) C 3b NG

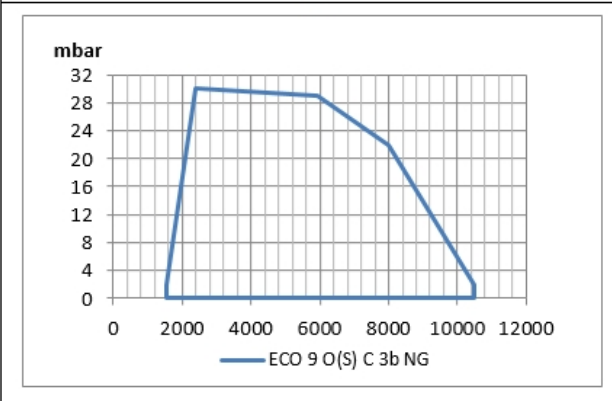

ECO 9 O (S) C 3c NG

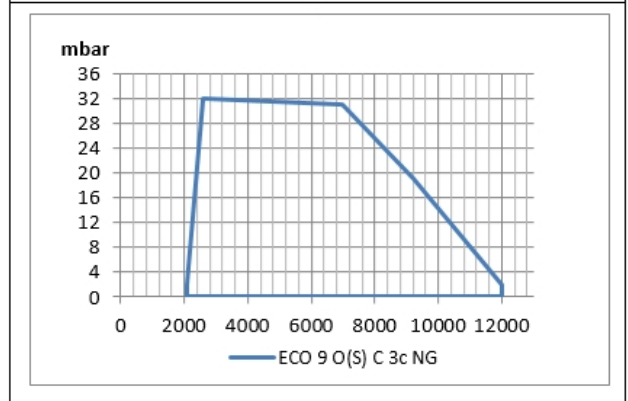

5.3. Outer Dimensions

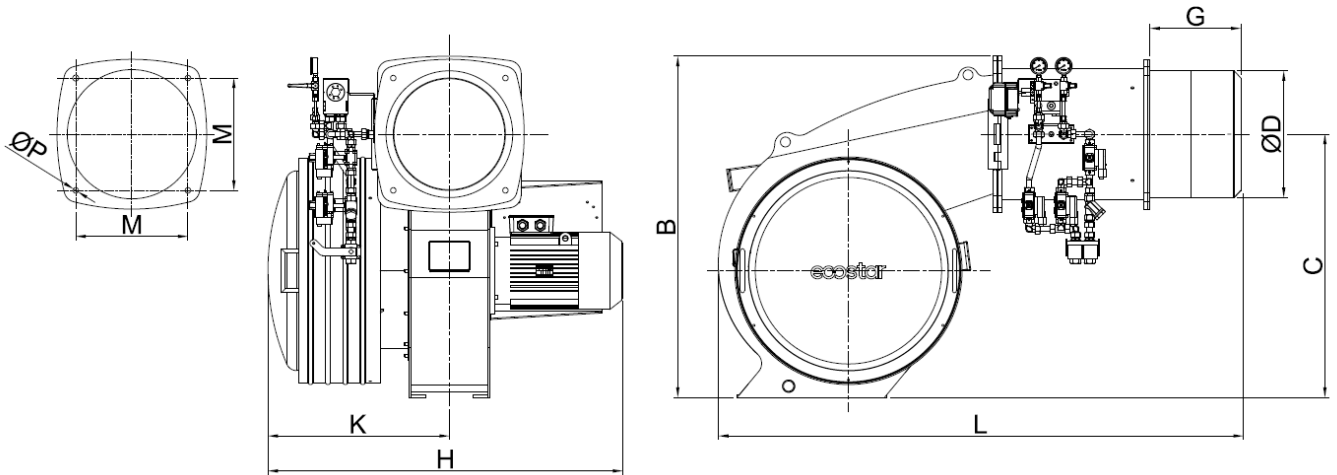

| | L | G | H | K | B | C | $\varnothing P$ | M | $\varnothing D$ |
|------------------------|------|-----|------|-----|------|------|-----------------|-----|-----------------|
| ECO 8 OSC3 NG | 1830 | 300 | 1320 | 720 | 960 | 695 | 18 | 400 | 408 |
| ECO 8.5 OSC3 NG | 2110 | 375 | 1450 | 750 | 1370 | 1055 | 22 | 450 | 508 |
| ECO 9 OSC3 NG | 2110 | 375 | 1450 | 750 | 1370 | 1055 | 22 | 450 | 508 |

5.4. Flame Length and Diameter

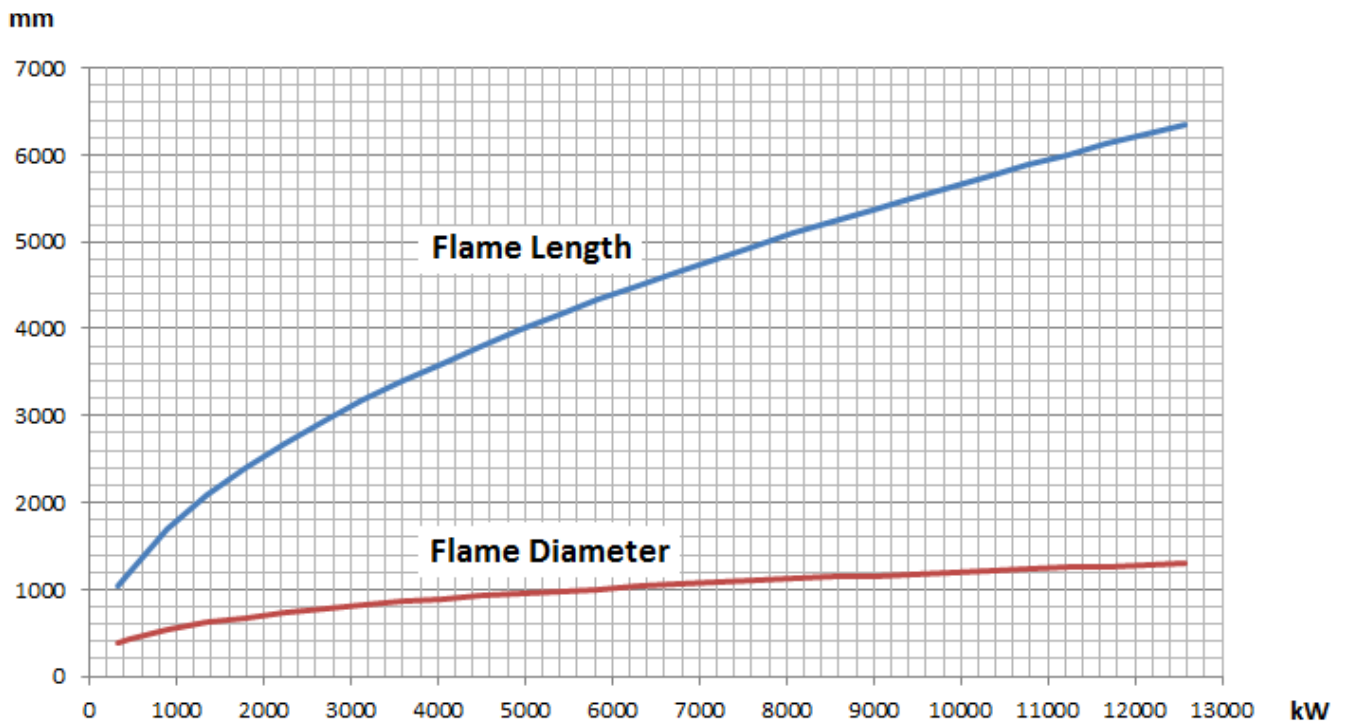

6. INSTALLATION

6.1. Burner Installation Picture

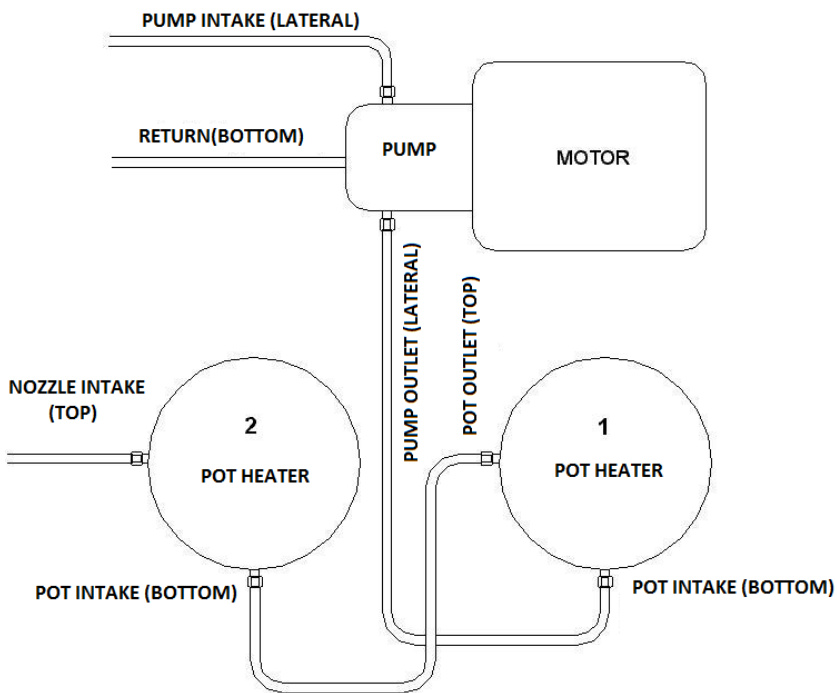
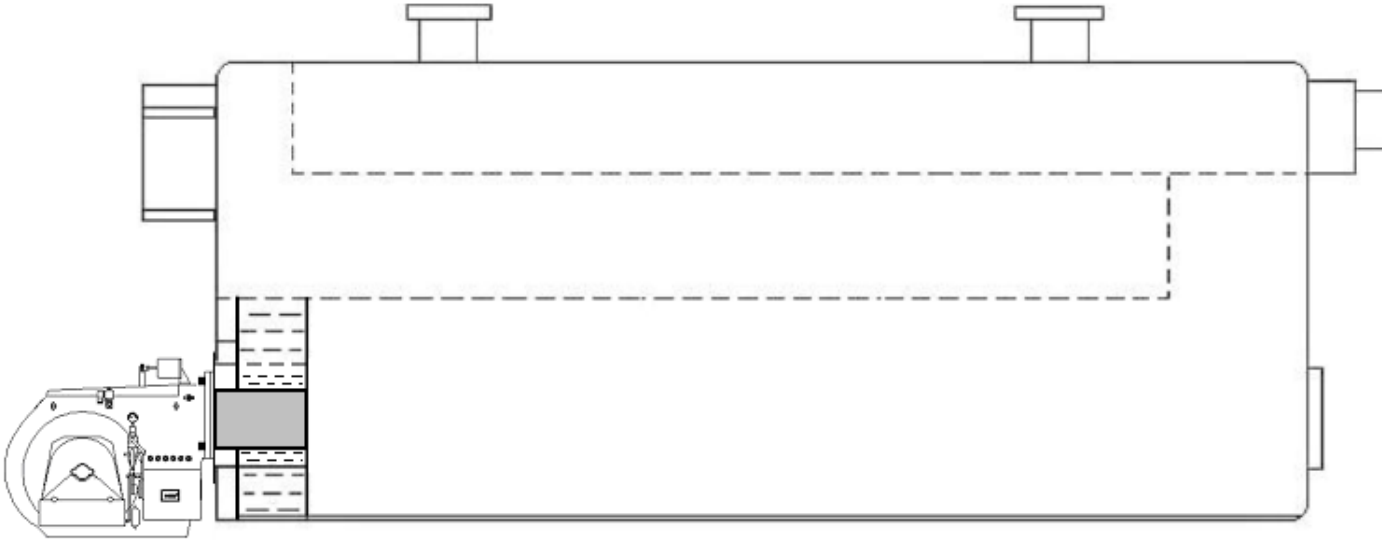

Fuel Pumping Station

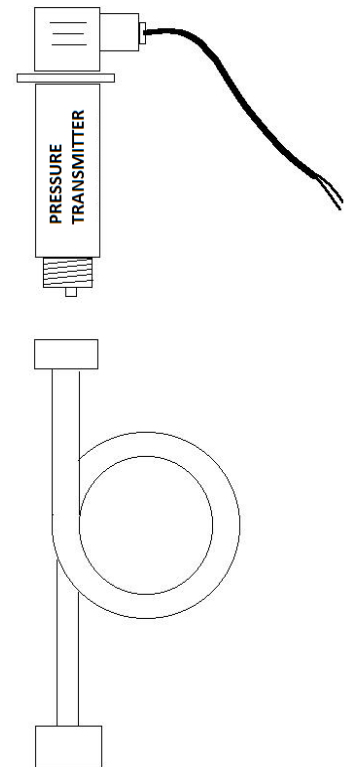

Interconnection of pressure transmitters

7. COMMISSIONING

7.1. General Controls



Electrical Connection

Perform electrical connections according to the diagram provided with the burner. Follow general security rules during installation of electric wiring and making connections. Connect the earthing terminal in electric panel to the earthing installation.



Make sure to perform the following controls before commissioning the burner.

- Ø Installation of the burner to the boiler is checked.
- Ø Check the fuel line (are the pipe diameters and the pipe installation correct?).
- Ø Check energy input cables and voltages.
- Ø Check the boiler safety thermostats.
- Ø Check the fuel nozzles according to the boiler capacity.
- Ø Prior to operating the burner, control the boiler water level.
- Ø Make sure water circulation system is turned on, and steam boiler and water feed pumps and boiler inlet - outlets are open.

Commissioning order

- Ø After performing the above mentioned controls, open the fuel tank valve.
- Ø Open the valve upstream of the fuel filter.
- Ø Check direction of motor rotation.
- Ø Open the pump's vent plug and place the manometer (0-40 bar).
- Ø Turn on the burner switch.
- Ø When the burner starts up, the motor is activated and turns the pump at the same time.
- Ø It actuates pre-purge and discharges the residual gases remaining in the boiler from the funnel.
- Ø After the pre-purge, fuel is delivered from the nozzle. The fuel meets the flame from the ignition electrodes and the combustion starts.
- Ø After combustion of the burner, the pump pressure is adjusted (modulating 25 bar).
- Ø The boiler thermostat is adjusted as desired (70-90°C for central heating boilers).
- Ø For the safety of the system, check the boiler thermostats and observe the deactivation of the burner.

7.2. Combustion Adjustment

Ø Photocell

Check the photocell weekly. Clean the dust or fume stains on the glass of photocell by a dry cloth.



7.3. Fuel Pumps

MF Type

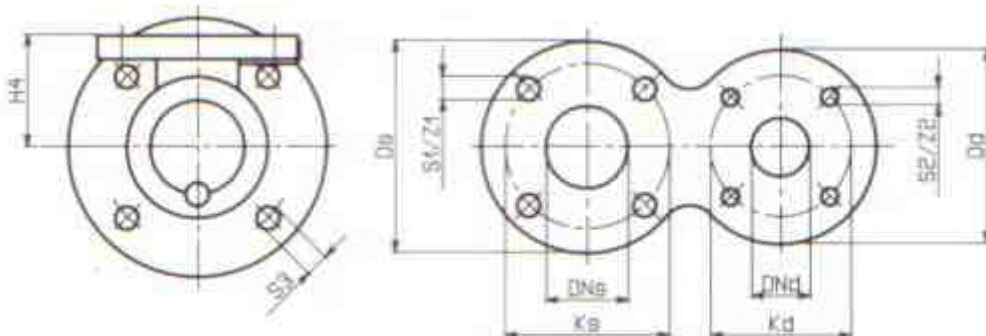
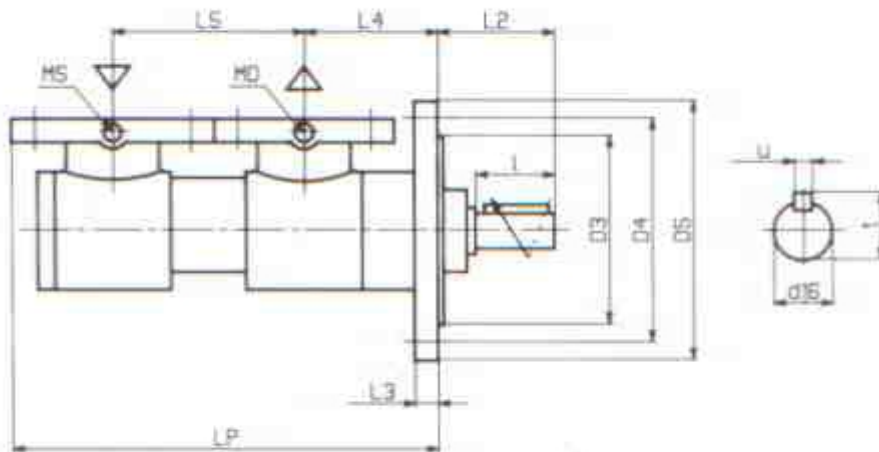

TA Type

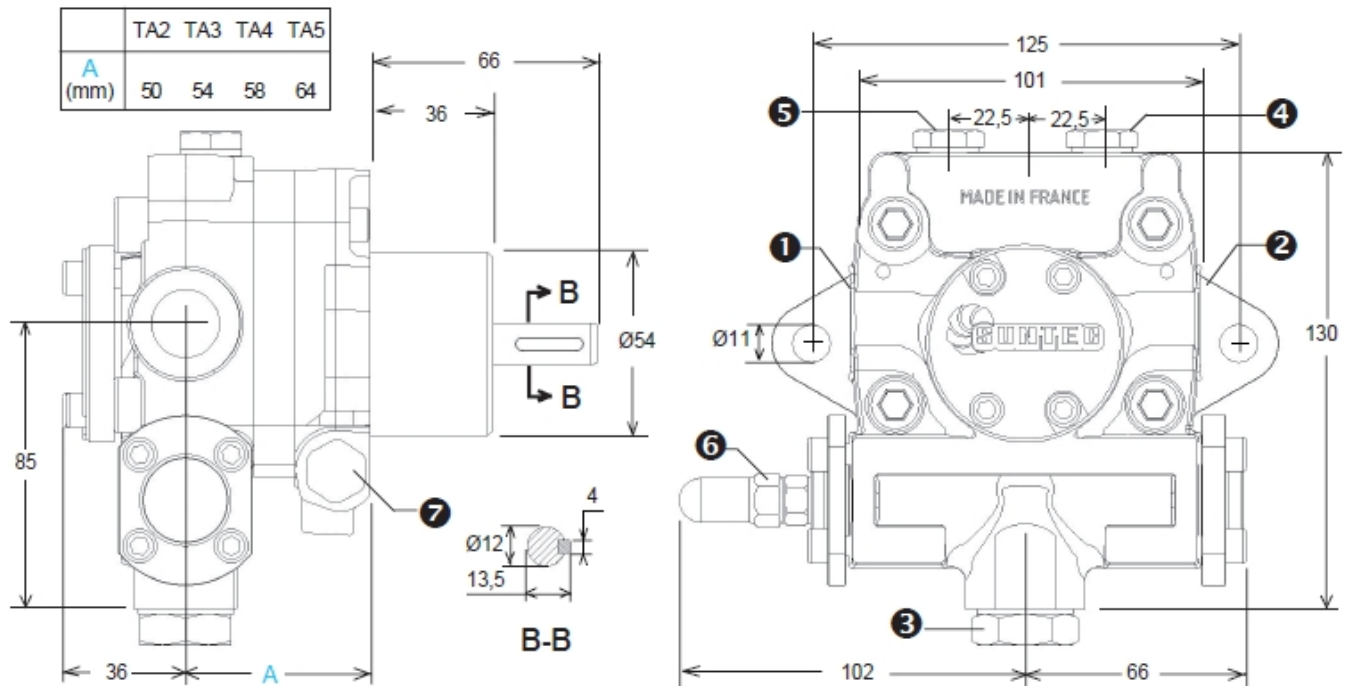

1. Suction
2. Nozzle outlet
3. Return
4. Manometer inlet
5. Vacuum or inlet manometer and internal return inlet
6. Pressure adjustment
7. Pre heater location

Application Limits

| | |
|---------------------------|--|
| Delivery pressure setting | 30 bars |
| Operating viscosity | 4 - 450 cSt |
| Oil temperature | 0 - 140°C max. in the pump light oil : 0,45 bars max. Vacuum to prevent air separation from oil |
| Inlet pressure | heavy oil : 5 bars max. |
| Return pressure | light oil : 5 bars max. heavy oil : 5 bars max. |
| Rated speed | 3600 rpm max. |
| Starting torque | 0,3 N.m |

Choice of heater

| | |
|---------------------------------|-----------------------|
| Cartridge | Ø 12 mm |
| Fitting according to DIN 40430, | NFC 68190 (N°9 elec.) |
| Rating | 80-100 W |

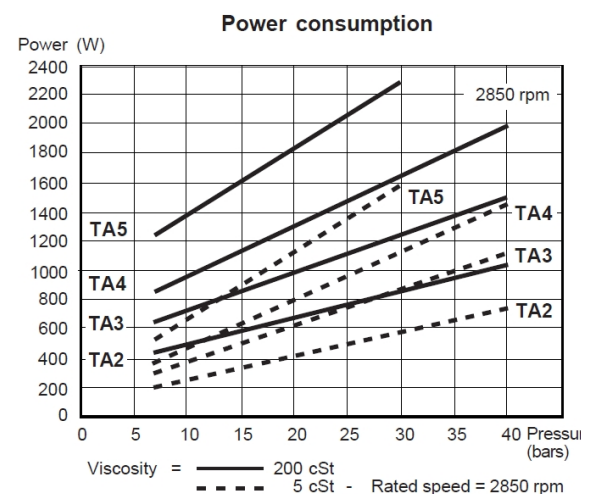

HP-UHE

Main Dimensions

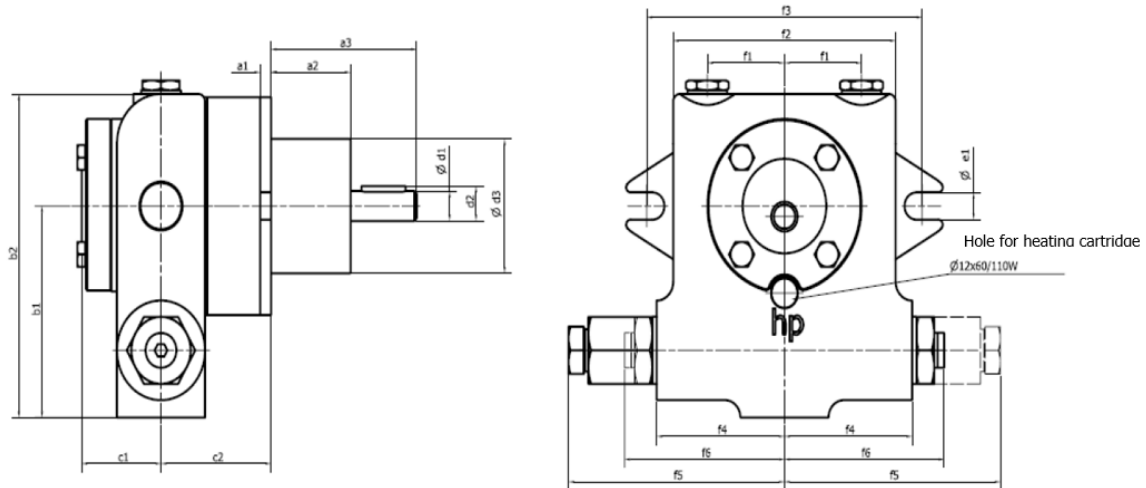

| Typ | a1 | a2 | a3 | b1 | b2 | c1 | c2 | d1 | d2 | d3 |
|-----------|----|----|----|----|-----|----|----|----|------|----|
| UHE-A2-PZ | 5 | 36 | 66 | 85 | 130 | 36 | 50 | 12 | 13,5 | 54 |
| UHE-A3-P | 5 | 36 | 66 | 85 | 130 | 36 | 54 | 12 | 13,5 | 54 |
| UHE-A4-M | 5 | 36 | 66 | 85 | 130 | 36 | 58 | 12 | 13,5 | 54 |
| UHE-A5-GZ | 5 | 36 | 66 | 85 | 130 | 36 | 64 | 12 | 13,5 | 54 |

| Typ | e1 | f1 | f2 | f3 | f4 | f5 | f6 | S; A; R | M1; M2 | M3 |
|-----------|----|----|-----|-----|----|----|------|---------|--------|------|
| UHE-A2-PZ | 11 | 35 | 101 | 125 | 58 | 98 | 72,5 | 1/2" | 1/4" | 1/8" |
| UHE-A3-P | 11 | 35 | 101 | 125 | 58 | 98 | 72,5 | 1/2" | 1/4" | 1/8" |
| UHE-A4-M | 11 | 35 | 101 | 125 | 58 | 98 | 72,5 | 1/2" | 1/4" | 1/8" |
| UHE-A5-GZ | 11 | 35 | 101 | 125 | 58 | 98 | 72,5 | 1/2" | 1/4" | 1/8" |

Inspection and Maintenance

- Ø The pump or motor-pump group is maintenance-free.
- Ø Every pump requires a suction filter on the suction side. The suction filter of the system must be open regularly. Soiling and leaks are checked. The mesh size of heating oil should be 80 to 100 microns. In the case of heavy oil, a mesh size of 540 microns must be provided because of the fibrous components. However, it is recommended, because of welded pipes at the beginning over a period of 1 - 2 Months also to drive with a mesh size of approx. 100 microns, until all scale and other Welding residues are filtered out. After this period has passed, filter with a mesh size of approx. 540 microns be changed.
- Ø Make sure that the suction connection of the pump (measured at the connection for the vacuum meter - see fig.) no vacuum greater than -0.4 bar occurs.
- Ø If the pump is operated with inlet pressure, this must **not exceed 5 bar**

Application limits

| | |
|--|--|
| Delivery rate | 375 ± 25 l / h |
| Max. Pressure (adjustable on the integrated overflow valve) | up to 25 bar |
| Min. Admissible pre-pressure | - 0.4 bar |
| Max. Admissible pre-pressure | 5.0 bar |
| Max. permissible pump speed | 2800 min ⁻¹ at 50 Hz |
| Breakaway torque | 1.6 Nm |
| Temperature | up to 150 ° C |
| Perm. Test pressure for approvals | Max. 45 bar with the shaft seal removed (Shaft sealing area locked with a bush) |

AFI (ALLWEILER)

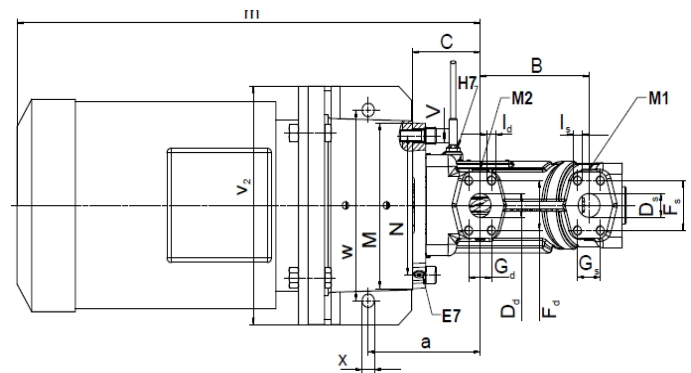
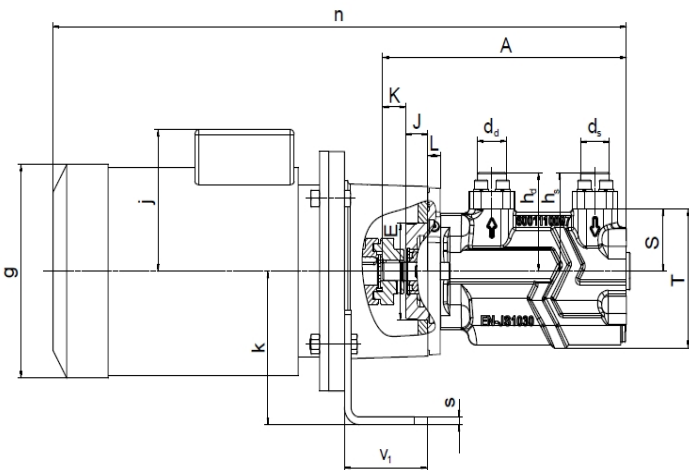

Shaft end

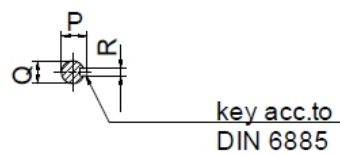

| AFI size | Pump dimensions | | | | | | | | | | | | | | |
|----------|-----------------|-----|------|------------------------|------|------|----|-----|-----|------|------------------|---|----|-----|----|
| | A | B | C | E | J | K | L | M | N | P | Q | R | S | T | V |
| 10 | 247 | 110 | 55,5 | 82,55 _{-0,05} | 19,4 | 21,6 | 13 | 130 | 106 | 16 | 14 _{±6} | 5 | 60 | 132 | 11 |
| 20 | 293,5 | 125 | 77,5 | 101,6 _{-0,05} | 27 | 26 | 15 | 175 | 146 | 21,5 | 19 _{±6} | 6 | 65 | 145 | 14 |
| 40 | 342,5 | 135 | | | | | 17 | | | | | | 80 | 164 | |

| AFI size | Motor size | Unit dimensions | | | | | | | | | |
|----------|------------|--------------------------|-------|----------------|----------------|----------------|----------------|----------------|----------------|-----|----------------|
| | | a | c | e ₁ | e ₂ | f ₁ | f ₂ | g [⊙] | j [⊙] | k | m [⊙] |
| 10 | 80 | 89,5 | 150,5 | 120 | 200 | 84 | 160 | 162 | 209 | 140 | 452 |
| | 90S | | | | | | | 181 | 218 | | |
| | 90L | | | | | | | 202 | 223 | | |
| | 100L | 111,5 | 202 | | | | | 223 | 160 | 546 | |
| 20 | 90S | 151,5 | 163 | 220 | 84 | 180 | 181 | 218 | 140 | 558 | |
| | 90L | 128,5 | | | | | 202 | 223 | 160 | 564 | |
| | 100L | | | | | | 227 | 238 | 170 | 571 | |
| | 112M | | | | | | 266 | 278 | 170 | 683 | |
| | 132S | | | | | | 141,5 | 181 | 218 | 140 | 558 |
| 40 | 90L | 151,5 | 212 | 240 | 84 | 200 | 202 | 223 | 160 | 564 | |
| | 100L | 128,5 | | | | | 227 | 238 | 170 | 683 | |
| | 112M | 141,5 | | | | | 266 | 278 | 170 | 683 | |
| | 132S | | | | | | 181 | 218 | 140 | 558 | |
| | 132M | | | | | | 202 | 223 | 160 | 564 | |
| | 160M | 150/ 415 [⊙] | | | | | 227 | 238 | 170 | 683 | |
| | | | | | | | 320 | 314 | 235 | 862 | |

Connections

| AFI size | Venting | Heating Cartridge | Pressure gauge |
|-----------|---------|-------------------|----------------|
| | E7 | H7 | M1/M2 |
| 10 | M8x1 | M12x1 | G 1/8 |
| 20 and 40 | | | G 1/4 |

| AFI size | Connection dimensions | | | | | | | | | | | | | |
|----------|-----------------------|----------------|----------------|----------------|----------------|----------------|----------------|-----------------------|----------------|----------------|----------------|----------------|----------------|----------------|
| | SAE-suction flange ① | | | | | | | SAE-pressure flange ① | | | | | | |
| | Inch | D _s | F _s | G _s | I _s | d _s | h _s | Inch | D _d | F _d | G _d | I _d | d _d | h _d |
| 10 | ¾ | 22 | 47,63 | 22,23 | 4 x M10 | 28 | 96 | ¾ | 22 | 47,63 | 22,23 | 4 x M10 | 28 | 96 |
| 20 | 1 | 25 | 52,37 | 26,19 | | 35 | 103 | 1 | 25 | 52,37 | 26,19 | | 35 | 103 |
| 40 | 1 ¼ | 32 | 58,72 | 30,18 | | 4 x M12 | 43 | 121 | 1 | 32 | 63,5 | | 27,14 | 40 |

HP Technik-Overflow Valve

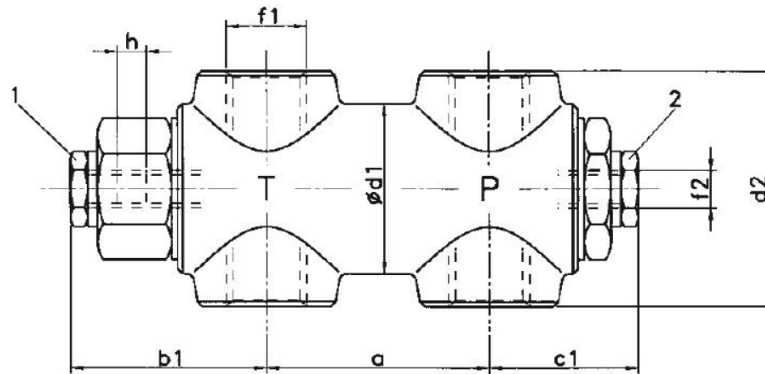

Fig.4 Dimensions

| Type | a | b1 | c1 | d1 | d2 | f1 | Max. pipe | NW | f2 | Adjustable range h at stage: | | | |
|--------------|----|----|----|----|----|----------|-----------|----|--------|------------------------------|----|---|-----|
| | | | | | | | | | | 0 + 1 | 2 | 3 | 4 |
| PP | 44 | 36 | 34 | 26 | 40 | G 1/4" | 10 x 1 | 8 | G 1/8" | 10 | 6 | 6 | 1,5 |
| P | 55 | 51 | 37 | 36 | 52 | G 3/8" | 12 x 1 | 10 | G 1/8" | 15 | 12 | 8 | 7 |
| G | 55 | 51 | 37 | 36 | 52 | G 1/2" | 18 x 1,5 | 15 | G 1/8" | 15 | 12 | 8 | 7 |
| GH | 63 | 57 | 43 | 50 | 70 | G 3/4" | 22 x 1,5 | 20 | G 1/4" | 15 | 10 | 8 | 5 |
| GHG | 80 | 71 | 60 | 56 | 86 | G 1" | 28 x 1,5 | 25 | G 1/4" | 20 | 17 | 9 | 6 |
| GHG - 1 1/4" | 80 | 71 | 60 | 56 | 86 | G 1 1/4" | 35 x 2 | 30 | G 1/4" | 20 | 17 | 9 | 6 |

Installation

- The pressure line which fluid pressure is to be regulated by the overflow valve, shall be connected to the pressure connection "P".
- Please connect the return flow line which has to lead back the controlled fluid from the regulating piston to the tank, to the return-flow / tank connection "T".
- The overflow valve can be connected at one pipe system to work as a max. Press. regulator (Fig.2)
- Should there be no manometer attached, please remove the plug screw 2 and fit one to the manometer connection G1/4" (Fig. 1).

NOTE : Water is not allowed to use as purging liquid, danger of corrosion!

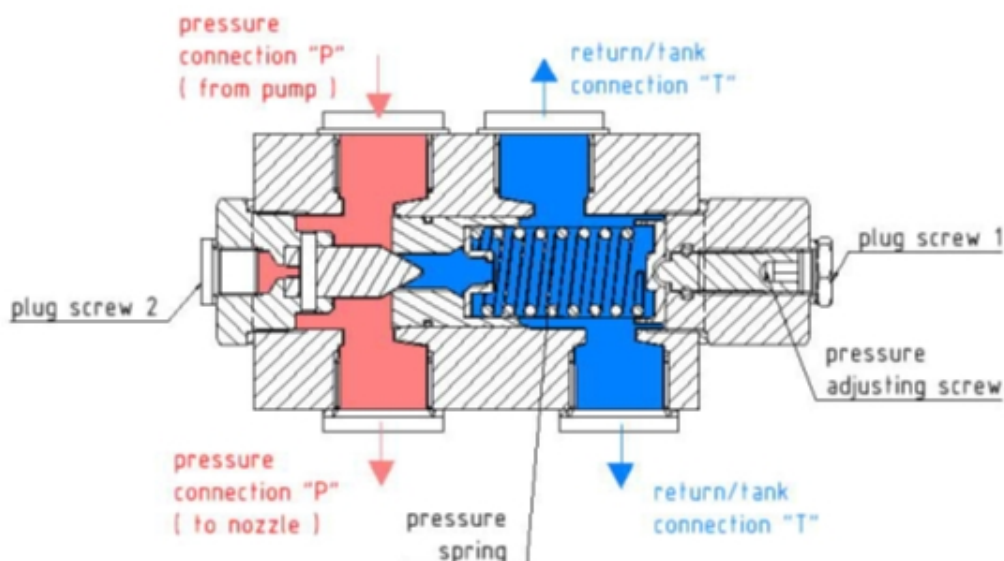

Fig.1 Operating principle

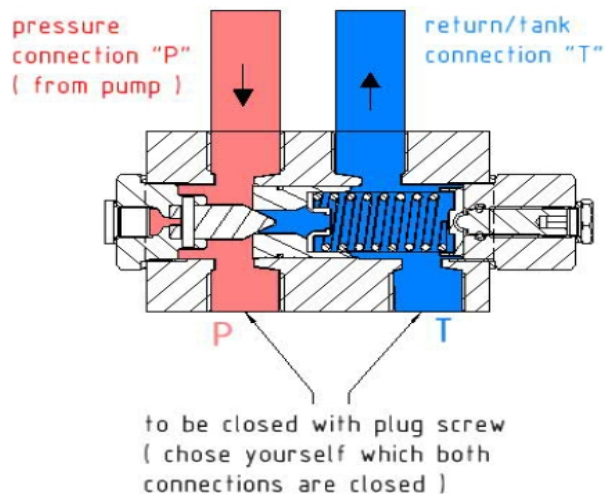

Fig.2 One pipe system

- Overflow valves have been factory-set to the lowest possible pressure level, In order to set the desired operating pressure, first remove the plug screw 1 (see Fig.1) to reveal the adjusting screw beneath.
- Now switch on the unit's pump and turn the adjusting screw to the right to adjust the operating pressure to the desired setting (turn the setting screw to the right – clockwise -> to increase the pressure, turn the setting screw to the left – counterclockwise -> to decrease the pressure. For a reading of the set value, a manometer to be attached to the unit. please remove the plug screw 2 (see Fig.1) and fit one to the manometer connection.
- After adjusting the pressure setting to the desired level, replace and retighten the plug screw 1. Assure that this screw is made tamper-proof as per Section 4.13 of DIN EN 12514-2

Model/Type designation: B-P-E/4



- B-P-E -> Overflow valve with flow rate 15 – 160 l/h
- 4 -> pressure stage

| Pressure stage | Pressure range |
|----------------|--------------------|
| 0 | from 0,5 - 1,5 bar |
| 1 | from 1 – 4 bar |
| 2 | from 2 - 9 bar |
| 3 | from 6 - 25 bar |
| 4 | from 15 - 40 bar |

Operational limits

Flow max. 10 000 l/h
 Temperature up to 150 °C
 Max. viscosity 450 mm²/s
 Ambient temperature -10 to +90 °C
 Storage temperature -10 to +60 °C

Ø **Modulating Heavy Oil Burner Fuel Diagram**

ECO 8 Fuel Diagram

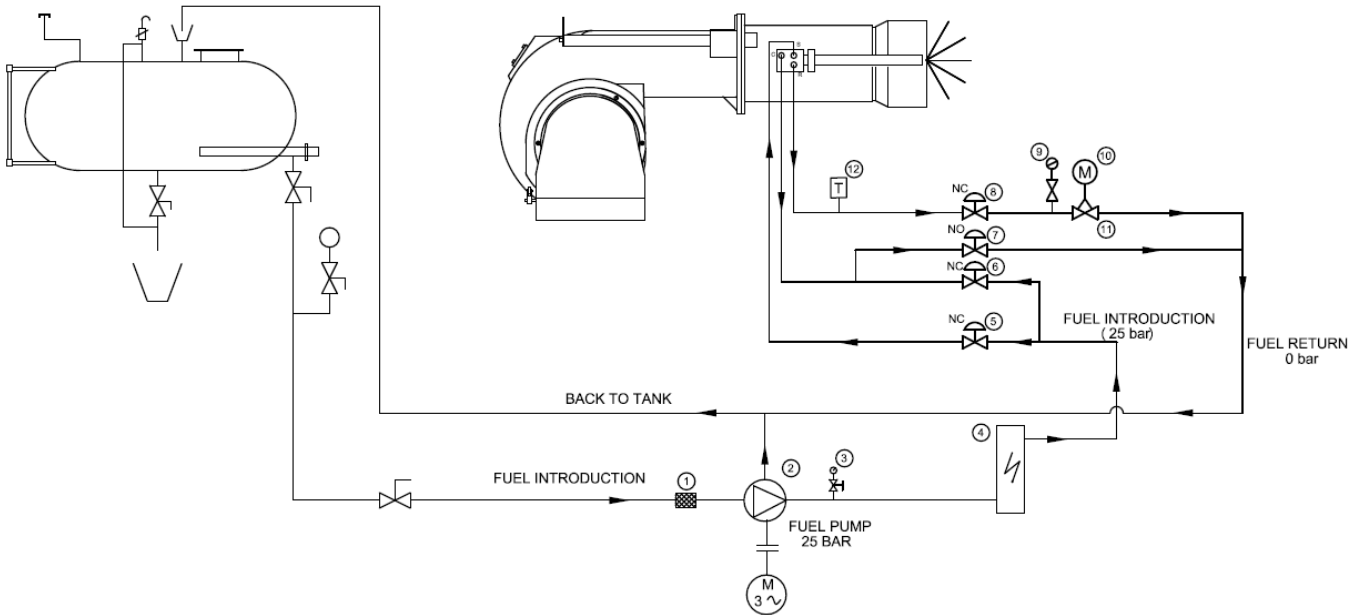

| | |
|----|--------------------------------------|
| 1 | FILTER |
| 2 | PUMP |
| 3 | MANOMETER |
| 4 | HEATER |
| 5 | INPUT VALVE |
| 6 | HYDRAULIC CONTROL VALVE |
| 7 | DRAINING THE HYDRAULIC CONTROL VALVE |
| 8 | OUTPUT VALVE |
| 9 | MANOMETER |
| 10 | SERVOMOTOR |
| 11 | OIL ADJUSTMENT VALVE |
| 12 | FUEL TEMPERATURE °C |



Fuel return line should be non-pressured line.

ECO 8,5-ECO 9 Fuel Diagram

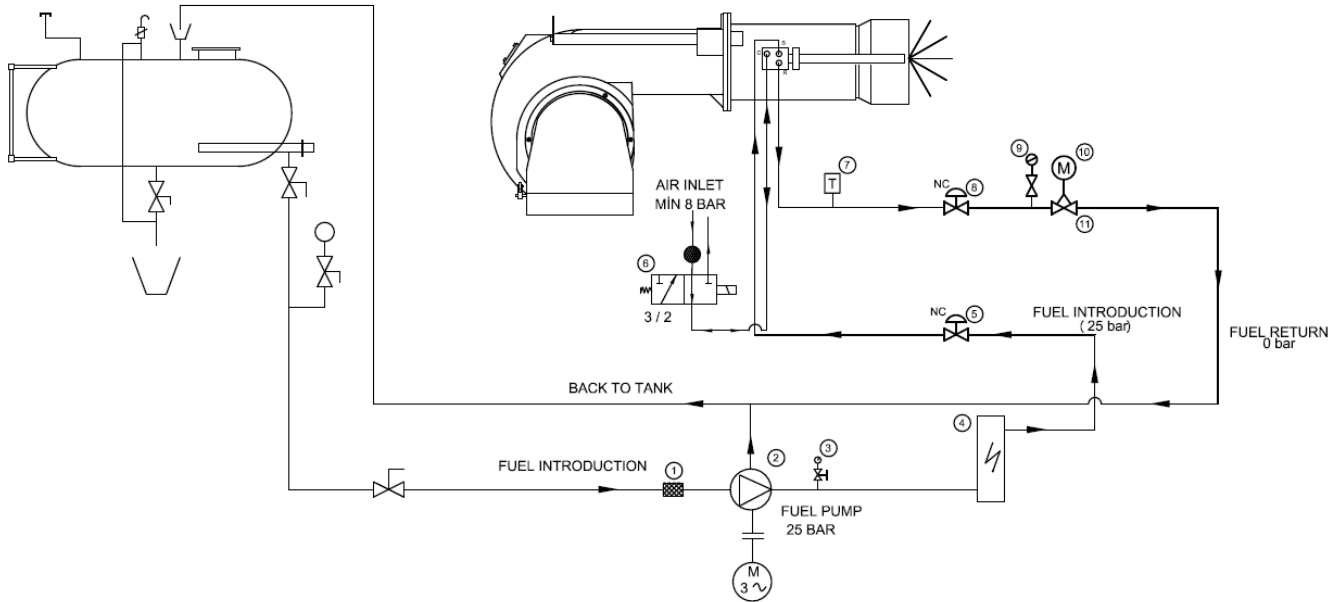

| | |
|----|------------------------|
| 1 | FILTER |
| 2 | PUMP |
| 3 | MANOMETER |
| 4 | HEATER |
| 5 | INPUT VALVE |
| 6 | 3/2 FUEL CONTROL VALVE |
| 7 | FUEL TEMPERATURE °C |
| 8 | OUTPUT VALVE |
| 9 | MANOMETER |
| 10 | SERVOMOTOR |
| 11 | OIL ADJUSTMENT VALVE |



Fuel return line should be non-pressured line.



CAUTION!

- Ø End of the line to the main tank must be open to the atmosphere and line pressure must be zero, otherwise no healthy modulating operation can be ensured since the pressure, which is to form in return, will also affect nozzle pressure. Fuel may drop from nozzle end during stops.
- Ø For good pulverization, periodically check durability of the o-ring. In the event of earing of the o-ring, fuel to the nozzle can by-pass and go directly to the return and reduces the working performance of the nozzle.
- Ø Maximum operating pressure of the nozzle is 30 bars, while its maximum operating temperature is 140°C. These values should not be exceeded during working. Even if these out of control value are exceeded, nozzle must be taken to emergency maintenance and all O-rings must be replaced.
- Ø Do not use solvent based materials (thinner and derivatives) during cleaning of the fuel nozzle; clean with gas oil or diesel oil. Fuel nozzle inner kit is very sensitive and even invisible deformations can reduce working performance; dismantling-installing work must be performed only by trained personnel.
- Ø Spring has lost its function if dropping from fuel nozzle or fuel exit at large scale is observed when the nozzle performs circulation. It must be checked and replaced if necessary.

Ø **Burner preheater**

1. Fuel inlet
2. Fuel outlet
3. Discharge
4. Fixing plate
5. Resistance
6. Thermostat bulb pipe
7. Housing cover

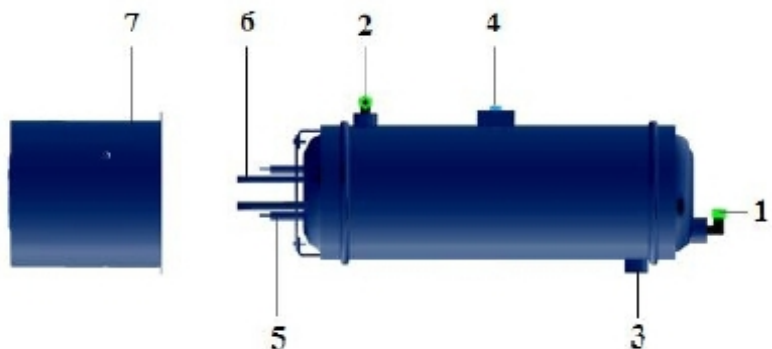

7.5.BT 300

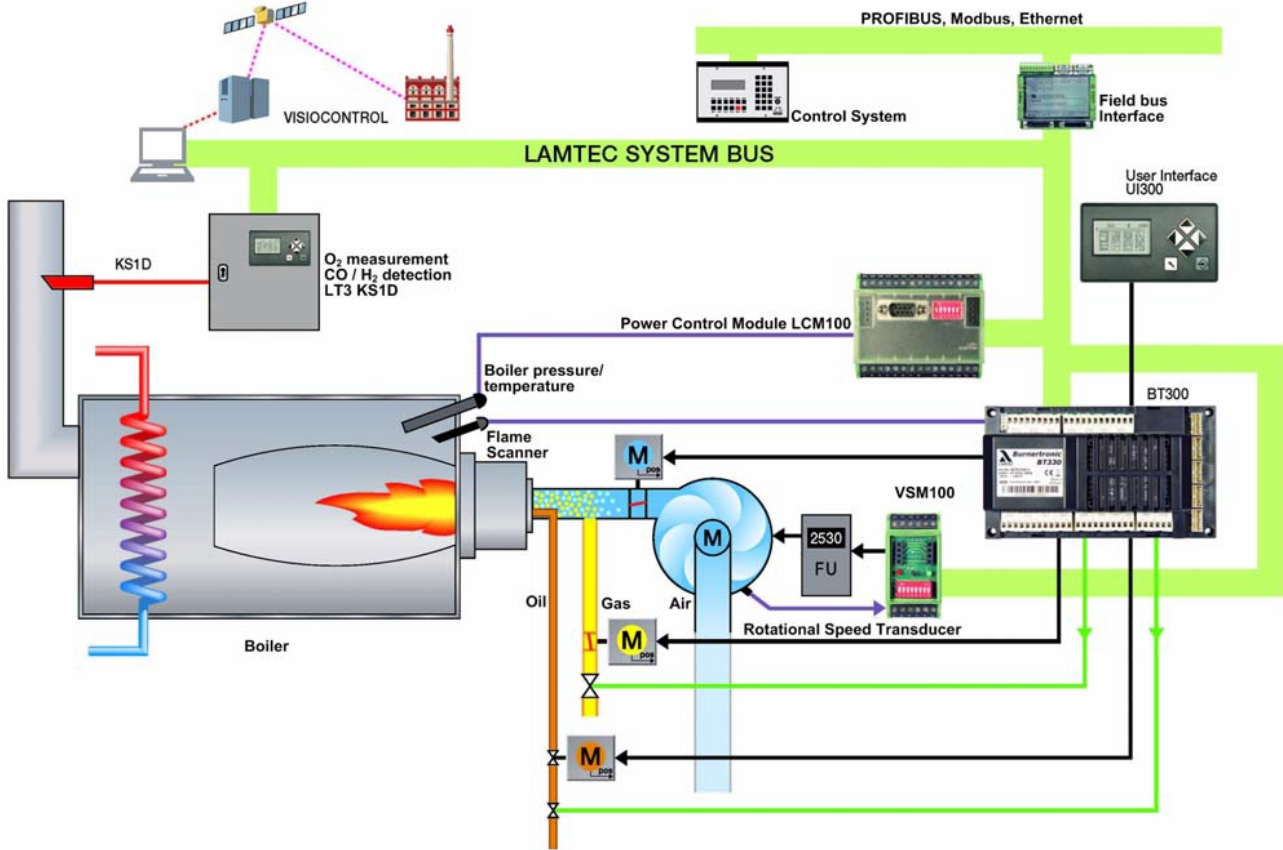

7.5.1. Operating Control and Displays

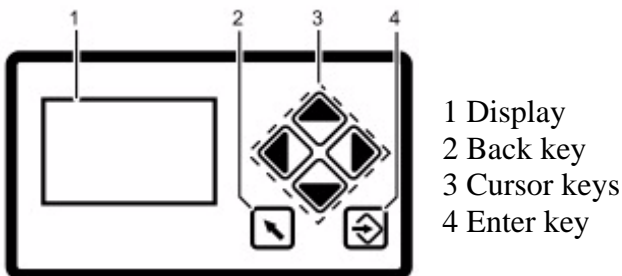

Display: The display shows in pictograms:

- 1 - the menu structure
- 2 - operating status
- 3 - parameters
- 4 - error messages



Back key: Jump to previous window.



Cursor keys: You navigate in the menu using the cursor keys. You use the "left" and "right" keys to move step by step to the selected row. At the end of the selected row, the cursor jumps to the next row down, if possible. If the menu has multiple rows, you can use the "up" and "down" keys to switch rows. To display the parameters, switch between the individual fields.



Enter key: Press ENTER to call up the menu on the start screen. You open the selected submenu from a menu window. By pressing the ENTER key, you transfer the setting values from a parameter window.

7.5.2. Menu Functions

The menu is divided into three paths:



INFO



MANUAL



SETTINGS

INFO



Select the INFO path for information about the following:

- the burner
- errors that have occurred
- the software version
- display of check sums
- the serial number
- actuating drive positions (current damper position for each channel)
- digital inputs/outputs

MANUAL



Select the MANUAL to

- start and stop the burner manually
- adjust the internal burner firing-rate

SETTINGS



Select the SETTINGS path for information on, and to make settings for, the following:

- the password
- the burner settings (display and settings)
- the actuator device settings (display)
- the air/fuel control system
- the "delete" curve
- the display settings

7.5.3. BT300 Connecting Diagram

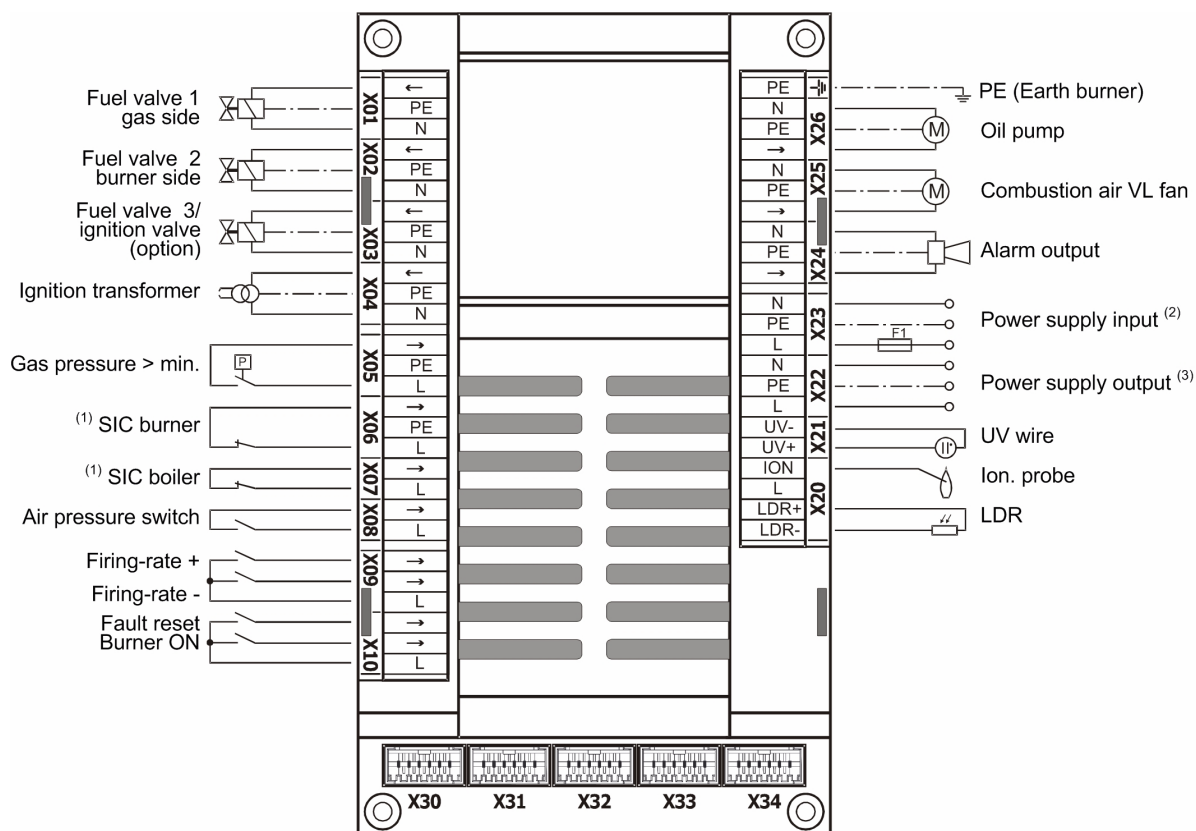

X30 = User Interface UI 300

X31 = LSB Option

X32 = continuous output 1, e.g. air damper

X33 = continuous output 2, e.g. gas damper

X34 = continuous output 3 (optional)

(1) SIC = safety interlock chain

(2) 230V AC 47 - 63Hz external fuse protection required (max 10A slow-blow)

(3) 230V AC for power supply to external devices

Maximum Cable Length:

X01-X10: 10m

X30: 1m

X20-X21: 3m

X31: 1m

X22-X23: unlimited

X32-X34: 3m

X24-X26: 10m

7.6. Servomotor

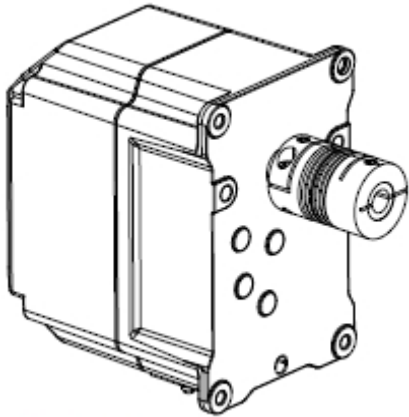

Lamtec motor ver. 2

Servomotors drive air dampers, gas butterfly valve and oil regulator. With the help of servomotors electronic air and fuel ratio control is carried out, controlled by burner control.



- Ø Static electricity can damage servomotor.
- Ø Do not open servomotor. Do not interfere with or modify unit or equipment connected to it. It may damage servomotor or change burner settings.
- Ø Completely isolate equipment from the main supply before performing any wiring changes in servomotor connection area.
- Ø Check that wiring is in an orderly state.
- Ø Protect equipment from condensation, water and ice.
- Ø Fall or shock can adversely affect safety functions. Such servomotors may not be put into operation.



Do not open servomotor. Do not interfere with. It may damage servomotor or change burner settings.

7.7. Function Controls and Adjustments

The BT300 combines the benefits of an electronic fuel-air ratio control system with up to three motorised actuating devices and an optional modules like an analogue output for speed control of the combustion air fan with an electronic burner control unit. The leakage test, flame monitoring system, power control unit and (optional) CO/O₂ controller for control and optimisation of an oil or gas-fired forced-draught burner are all integrated. The BT300 is suitable for virtually all combustion plants. Safety interlock chains, monitors (e.g. gas and air pressure) and sensors are wired directly to the BT300. This greatly reduces the cost of additional relays and wiring. The BT300 was designed to be attached to the burner. The short wiring paths also save money. As a result, the BT300 is particularly suitable as standard equipment for monoblock burners. The compact design of the BT300 burner control system also has its advantages during commissioning. Standardising the wiring and the unified operator interface minimises sources of errors from the start, while intelligent information in the display makes searching for errors much easier.



Magnetic valves must not be energized during pre-purge. Check if valves are in closed position!

7.8. Final Checks

- Ø Switch of all purges after completion of all necessary measurements.
- Ø Start and stop the burner at least 3 times to check the operation of the program.
- Ø Make sure that all safety circuits on the burner and boiler operate properly before leaving the installation site.

Ø Oil adjustment regulator

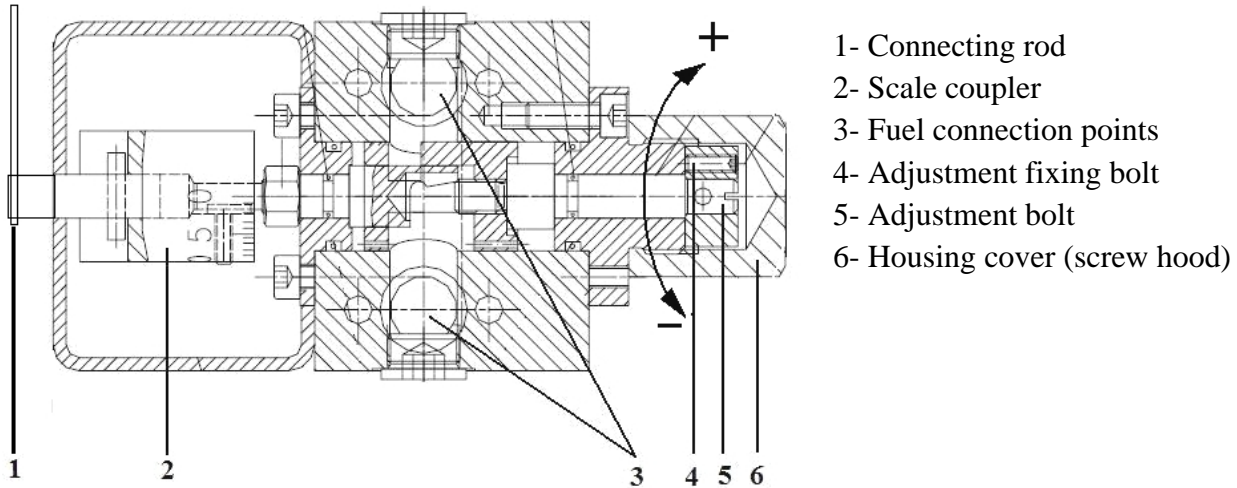

- 1- Connecting rod
- 2- Scale coupler
- 3- Fuel connection points
- 4- Adjustment fixing bolt
- 5- Adjustment bolt
- 6- Housing cover (screw hood)

Fuel regulator adjustment

- 1- Remove the housing cover number 6
- 2- Loosen the fixing bolt number 4
- 3- When you rotate the shaft number 5 (when looked from the shaft end) clockwise, the pressure value you observe from return manometer will increase, and burner consumption will also increase since nozzle pressure increases.
- 4- When you rotate the shaft number 5 (when looked from the shaft end) anti-clockwise, the pressure value you observe from return manometer will decrease, and burner consumption will also decrease since nozzle pressure decreases.
- 5- When the adjustment is completed, make sure that the adjustment you have made is permanent by tightening the fixing bolt number 4.
- 6- Place the housing cover number 6.

| | | |
|---|------------------------|--------------|
|  | Atomizer 12 | 12-E1L1-DG-E |
| | W(R)2-"Size"-60° | |
| | Supply pressure 25 Bar | |
| | Viscosity 5 cSt | |
| OUTPUT CHARACTERISTICS | | 12-05-14 |

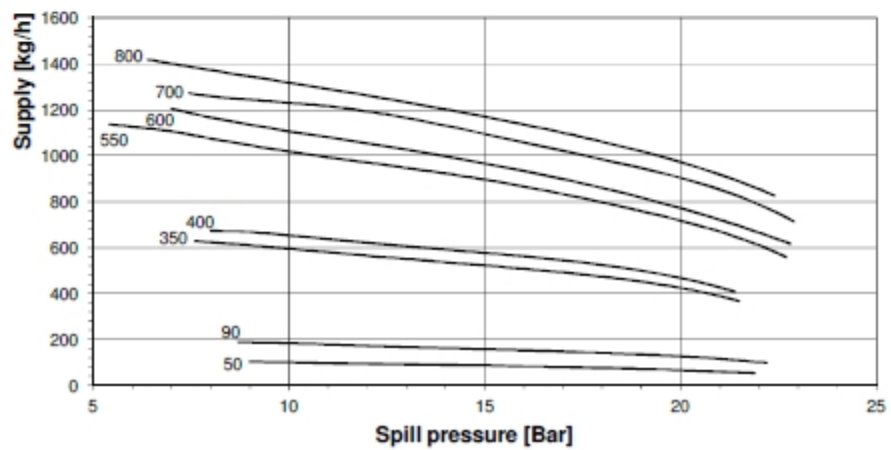
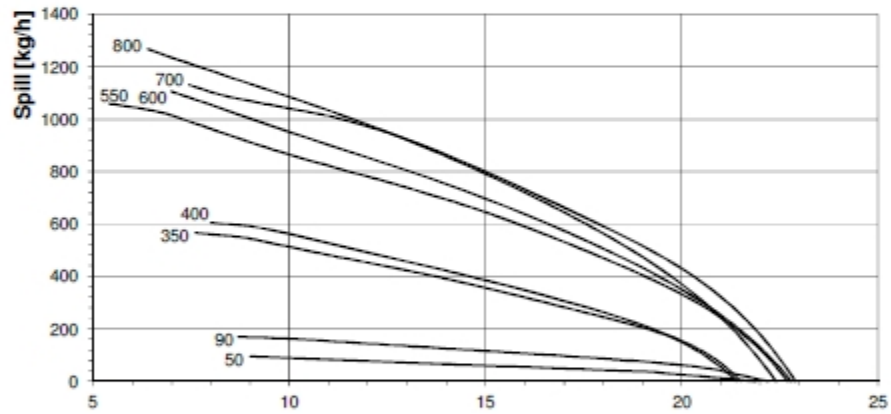
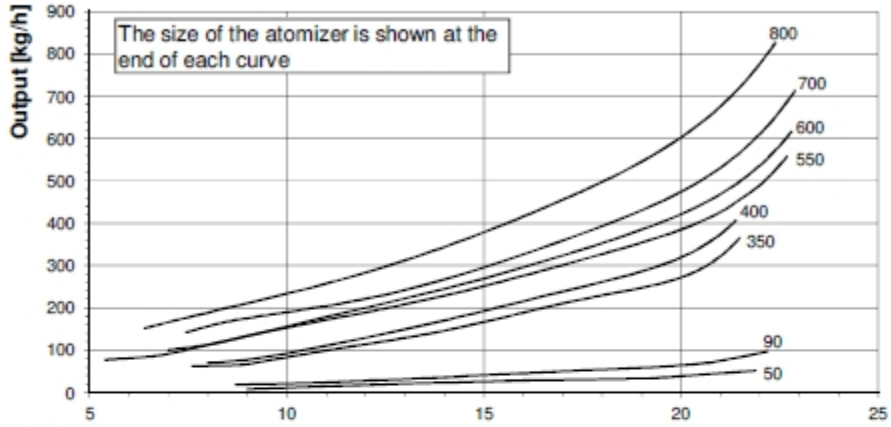

7.9. Pilot Ignition System

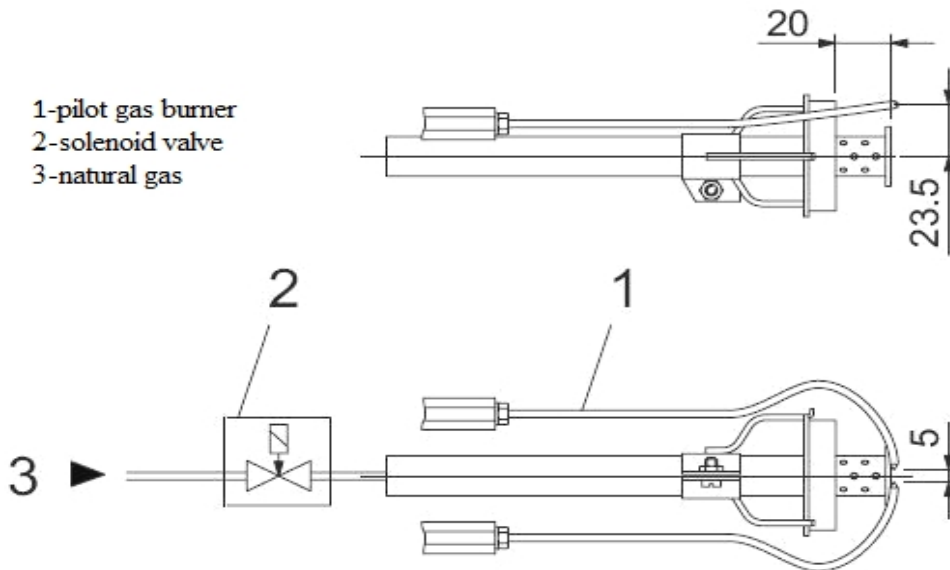

Pilot gas burner inlet pressure $P_{max} = 200$ mbar

7.10. Emission Measurement

In emission measurements, the following values are accepted as reference according to TS EN 267 standard.

- Ø $CO < 110$ mg/ kWh
- Ø $\%3 \leq O_2 \leq \%5$
- Ø $NO_x < 250$ mg/ kWh
- Ø Excess air ratio $1,2 \leq \lambda \leq 1,3$



It is important for the boiler to be sealed in order to avoid incorrect measurements during emission measurements.



Boiler temperature must be between 40 C° and 80 C° while making emission measurement in hot water boilers.

7.11. Heavy Oil Burner Fuel Ring Line

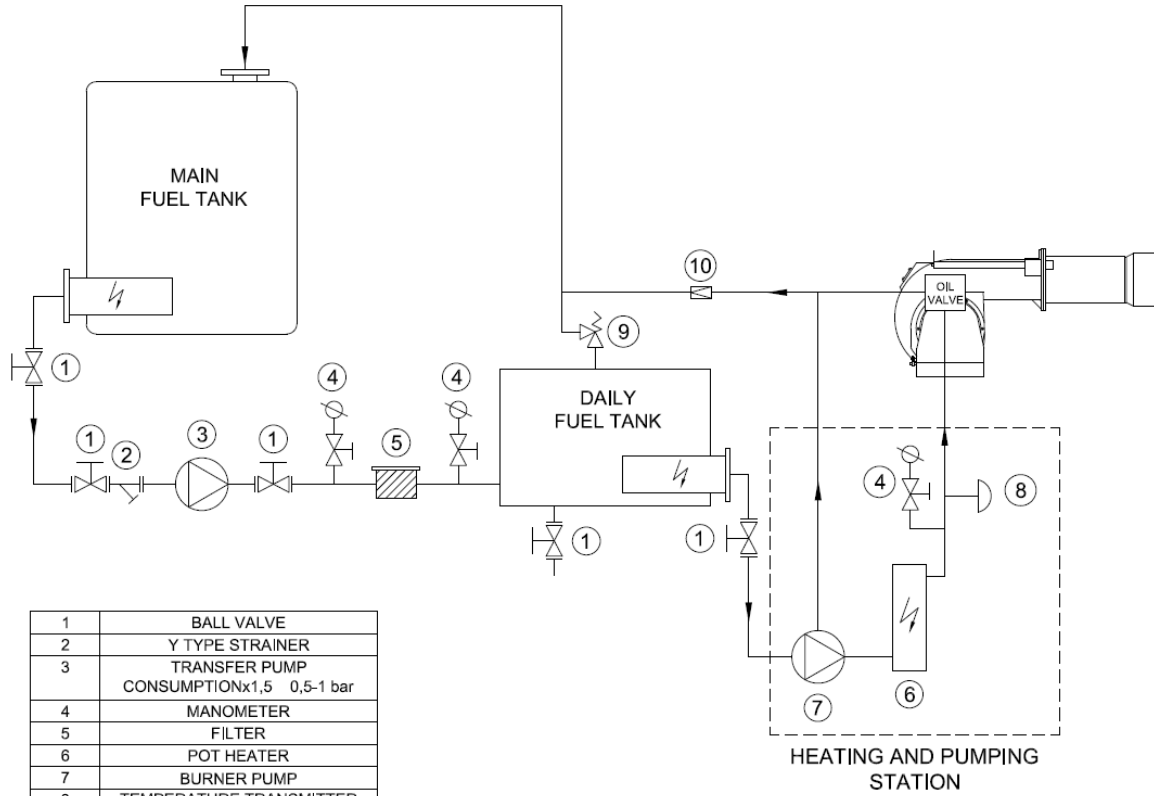

| | |
|----|--|
| 1 | BALL VALVE |
| 2 | Y TYPE STRAINER |
| 3 | TRANSFER PUMP CONSUMPTIONx1,5 0,5-1 bar |
| 4 | MANOMETER |
| 5 | FILTER |
| 6 | POT HEATER |
| 7 | BURNER PUMP |
| 8 | TEMPERATURE TRANSMITTER |
| 9 | RELIEF VALVE (3/4" WITH SPRING) |
| 10 | CHECKVALVE (1" WITH SPRING) |

* POT HEATER AND OIL PUMP MIGHT BE COUPLED WITH BURNER BODY OR COME AS A SEPARATE FILTERING-PUMPING-HEATING GROUP ACCORDING TO BURNER CAPACITY.

8. MAINTENANCE

8.1. Weekly Maintenance

Weekly maintenance is a routine cleaning and adjustment procedure which is performed to ensure smooth and continuous operation of the system. Burner components must be adjusted after each maintenance work in accordance with the instructions. Otherwise, the burner cannot be operated efficiently.

- Ø Clean all filters in fuel ring system.
- Ø Clean fuel nozzle of the burner.
- Ø If the fin spaces and surface of the diffuser are covered with particles and formed a layer, clean it with a wire brush.
- Ø Clean heads of ignition electrodes. Check by performing manual ignition, adjust the distance between the ignition electrode and diffuser according to the adjustment instructions.

8.2. Monthly Maintenance

Monthly maintenance is a more comprehensive maintenance compared to weekly maintenance, where general checks of burner and peripheral components are performed to prevent possible faults. After completion of maintenance and adjustment processes, make sure to perform a combustion analysis.

- Ø Clean the filters on the fuel line to the burner.
- Ø Clean fuel nozzle of the burner.
- Ø Clean the surface of the diffuser.
- Ø Clean flame pipe.
- Ø Check all wiring points. Tighten loose connections.
- Ø Clean the solenoid valves.
- Ø Clean the photocell.
- Ø Clean the dust and layers accumulated on the fan and air valves.
- Ø Check pump pressure. Check if necessary (Heavy-Oil: 25 bar)
- Ø Check ignition electrodes. Adjust it if necessary. Check ignition cables and sockets.
- Ø Perform cleanliness control of inside panel. Clean if necessary.
- Ø Check all bolts of the burner. Tighten loose bolts.
- Ø After starting the burner and adjusting air klappe, perform flue gas analysis and check if there is an ideal combustion.

8.3. Seasonal Maintenance

Comprehensive maintenance work when the burner is re-started after long periods of shut-down or interruptions. After completion of maintenance and adjustment processes, make sure to perform a combustion analysis.

- Ø Check insulation resistance of electric motor.
- Ø Make surface cleaning of ignition electrodes and porcelains. Replace cracked or broken porcelains.
- Ø Clean air fan and clamps.
- Ø Check the operating function.
- Ø Check cleanliness of the nozzle. Replace it if necessary.
- Ø Clean the N.C. solenoid valve. Measure the coil winding resistance.
- Ø Clean the strainer (filter) under the pump cover.
- Ø Clean the photocell.
- Ø Clean fuel filter. Replace it if necessary.
- Ø Check boiler thermostats.
- Ø Check cleanliness of boiler inside and clean if necessary.

9. FAULT HISTORY

Reading fault situation from the control panel

Active fault situation is shown on display. Enter-button is lit. Fault history can be read from the control panel.

See more precise fault codes in the brochure on burner control.

Resetting fault

Example

- 01: fault code H333
- D1: diagnostic code (additional information)
- D2: diagnostic code (additional information)
- clock: running hours counter in fault situation

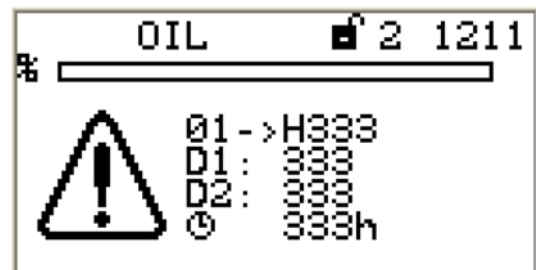

Burner control can be reset immediately after lockout. After resetting the actuators drive to stand by position. In stand by position control unit allows burner to restart.

| 10. PERIODICAL FLUE GAS MEASUREMENT REPORT | | | | | | | | |
|---|---------------------|------------------------------|---------------------------------|---------------------------------|----------------------|----------------------------|-------------|------------------|
| Fuel Consumption (kg/h) | CO (ppm) | O₂ (%) | CO₂ (ppm) | NO_x (ppm) | Yield (%) | Flue Temp. (°C) | Date | Signature |
| | | | | | | | | |
| | | | | | | | | |
| | | | | | | | | |
| | | | | | | | | |
| | | | | | | | | |
| | | | | | | | | |
| | | | | | | | | |
| | | | | | | | | |
| | | | | | | | | |
| | | | | | | | | |
| | | | | | | | | |
| | | | | | | | | |
| | | | | | | | | |
| | | | | | | | | |
| | | | | | | | | |
| | | | | | | | | |
| | | | | | | | | |
| | | | | | | | | |
| | | | | | | | | |
| | | | | | | | | |
| | | | | | | | | |
| | | | | | | | | |
| | | | | | | | | |
| | | | | | | | | |
| | | | | | | | | |
| | | | | | | | | |
| | | | | | | | | |
| | | | | | | | | |
| | | | | | | | | |
| | | | | | | | | |

11. AFTER SALES SERVICES

Dear Customer,

We believe that providing a good service is as important as providing a good product. Therefore, we continue offering wide range of comprehensive services to our conscious customers.

Our contact details for your requests and complaints

Esentepe Mah.Milangaz Cad. No:75 K:3

Kartal Monumento Plaza

KARTAL/İSTANBUL/TÜRKİYE

Tel: +90 216 442 93 00

Fax: +90 216 370 45 03

Factory Contact Details

Türkgücü OSB

Bülent Ecevit Bulvarı No:11

ÇORLU/TEKİRDAĞ/TÜRKİYE

Tel: +90 282 685 44 80-81

Fax: +90 282 685 42 09

Also you can contact with us:

Web site : www.ecostar.com.tr

E - mail : servis@ecostar.com.tr



Please observe the following recommendations.

- Use the product in accordance with the principles of this manual.
- For any service demands regarding the product, please contact our Service Center from the abovementioned phone numbers.
- Upon your purchase, register your warranty certificate during installation.

