



# CONDENSING BOILER INSTALLATION, OPERATING AND MAINTENANCE MANUAL



ECODENSE FT-SS 250  
ECODENSE FT-SS 350  
ECODENSE FT-SS 450  
ECODENSE FT-SS 550  
ECODENSE FT-SS 650  
ECODENSE FT-SS 750  
ECODENSE FT-SS 850  
ECODENSE FT-SS 950  
ECODENSE FT-SS 1050

31.03.2023 Rev. 01

[www.ecodense.com](http://www.ecodense.com)

**DEAR USER,**

The Condensing Boilers ECODENSE FT-SS 250, ECODENSE FT-SS 350, ECODENSE FT-SS 450, ECODENSE FT-SS 550, ECODENSE FT-SS 650, ECODENSE FT-SS 750, ECODENSE FT-SS 850, ECODENSE FT-SS 950, ECODENSE FT-SS 1050, are constructed and manufactured according to the most advance technological inventions and the safety rules. It is easy to use for our customers.

We recommend that you read this manual and safety warnings thoroughly before the use of the device in order to ensure safe, cost effective and environmental-friendly use.

If you encounter any issue that is not explained clearly in this manual or you could not understand, please contact with our service department.

We thank you for choosing ECODENSE brand.

This Operating Manual is an integral part of the device and must be maintained in a plastic dossier and hung at a clearly visible place by the device.

**TERMO ISI SİSTEMLERİ SAN.VE TİC.A.Ş.**

Esentepe Mah.Milangaz Cad. No:75 K:3

Kartal Monumento Plaza

Kartal/İSTANBUL/TÜRKİYE

Tel: +90 216 442 93 00

Fax: +90 216 370 45 03

[www.ecodense.com](http://www.ecodense.com)









[e-mail:servis@ecodense.com](mailto:servis@ecodense.com)

## CONTENTS

1. WARNINGS.....	3
1.1. Warning Symbols and Descriptions.....	3
1.2. General Safety Rules.....	4
2. TERMS OF WARRANTY.....	6
2.1. Out of Warranty Conditions.....	6
3. GENERAL CHARACTERISTICS OF CONDENSING BOILER.....	7
3.1. Usage of CASCADE.....	7
3.2. ECODENSE Components.....	8
4. CONDENSING BOILER GAS, FLUE GAS AND HEATING WATER SCHEMA.....	10
5. CIRCUIT SCHEMES.....	11
6. BOILER WATER FLOW TABLE.....	12
7. CLOSED CIRCUIT COMPONENTS.....	13
7.1. Balance Tank.....	13
7.2. Sizing Table For Expansion Tank.....	14
7.3. Expansion Tank.....	15
7.4. Manometer.....	15
7.5. Strainer.....	15
7.6. Air Separator.....	15
8. WATER QUALITY.....	16
9. TECHNICAL DATA.....	17
9.1. Capacity Table.....	17
9.2. Condensing Boiler Dimensions.....	18
9.3. Noise Level.....	18
10. INSTALLATION.....	19
10.1. General Controls.....	19
10.2. External Outdoor Sensor (Optional).....	19
11. STACK CONNECTIONS.....	20
12. ASSEMBLY.....	21
12.1. ECODENSE Assembly Instructions.....	21
12.2. ECODENSE Single/CASCADE Assembly Instructions.....	21
12.3. Assembly of Condensing Fluid Drain.....	21
13. ECODENSE CONTROL INSTRUCTIONS BEFORE START-UP.....	23
14. ELECTRICAL DIAGRAM.....	25
15. COMMISSIONING.....	26
15.1. Before Commissioning.....	26
15.2. Checks During Commissioning.....	27
16. ADJUSTING COMBUSTION PARAMETERS.....	28
16.1. Adjustment and Measurement Points.....	28
17. CONTROL PANEL BUTTON SPECIFICATIONS.....	29
17.1. Adjusting Minimum Capacity.....	29
17.2. Adjusting Medium Capacity.....	29
17.3. Adjusting Maximum Capacity.....	30
17.4. Adjusting Time Schedule.....	30
18. MAINTENANCE.....	31
18.1. Monthly Maintenance.....	31
18.2. Seasonal Maintenance.....	31
19. LIST OF ERROR CODE.....	32
20. SOLUTION RECOMMENDATIONS FOR SOME OF THE PROBLEMS.....	36
21. AFTER SALES SERVICES.....	37
22. NOTES.....	38

## 1. WARNINGS

### 1.1. Warning Symbols and Descriptions

Symbols	Symbol Descriptions
	Important information and useful hints.
	Warning of danger to life or property.
	Warning of electrical voltage.
	Product handling information.
 <p data-bbox="320 1137 563 1211">GAZ HATTINI TEMİZLEYİNİZ. CLEAN GAS LINE. ЧИСТАЯ ЛИНИЯ ГАЗ.</p>	"Clean the gas line" warning on gas line.
   	Carry in an upright position. Fragile Item. Protect against water.

## 1.2. General Safety Rules

- All personnel engaged in installation, disassembly, commissioning, operation, control, maintenance and repair should have received the necessary training, qualified and fully read and understood this manual.
- No changes that might damage the safety of the device must be made by persons and/or organizations on the device.
- All operation, commissioning and installation works (except for burning adjustment) should be carried out when the device is not operating and after disconnecting the power supply. Noncompliance with these rules may lead to serious bodily injuries and even death by electrical shocks or uncontrolled flame formation.
- Repairs concerned with safety elements should be carried out only by the manufacturing company.
- The device should never be used by children, mentally handicapped and inexperienced persons.
- Children must not be allowed to play with the device.
- Keep the device away from explosive and flammable materials.
- Device must intake air, and ventilation and air discharge holes must not be closed.



### **If you sense gas leakage;**

- Shut down valves of all gas devices.
- Open all doors and windows.
- Do not turn on electric devices or do not turn them off if they are working.
- Do not use burner derived tools such as match and lighter.
- Inform the gas company.



Do not store any inflammable materials in boiler room.



Wear hearing protectors if there is noise in boiler room.



### **In case of fire or other emergency;**

- Switch off the main switch
- Close the main fuel shut-off valve outside the plant.
- Take appropriate actions



Products should be stored in a dry, cool or dry conditioned places . Storage life of our products (service life) is 10 years.



Preventing damage caused by the presence of particles such as dirt, sediment, metal burrs on the heating circuit installation and condensing boiler, for the comfortable and longer service life of the boilers, It is recommended that the installation circuit is separated by plate heat exchanger as primary and secondary circuit



For The High-rise Buildings, If height of structure more than 25 mt. Or more than 10 th floor , in order to ensure that condensing boiler cascade system operates comfortably at low pressures, a plate heat exchanger must be installed in order to distinguish the high pressure between 2nd circuit and the Primary circuit. the static pressure appeared due to the height of building , the boiler system is not allowed to operate under the influence of high pressure.



## **BOILER ROOM**

Condensing Boilers must be installed in a suitable room/floor with minimum external air openings and sufficient to ensure optimum gas-air mixture combustion, in compliance with the regulations.

Air openings of the boiler room, burner fan intake vents or air ducts must stay open to the atmosphere and Bird cage should be installed in order to prevent any Bird, foreign body entrance

- a. The build up of toxic / explosive gas mixtures in the boiler room,
- b. Combustion with insufficient air, resulting in hazardous, anti-economical and polluting operation.

The Condensing boiler must be always protected from rain, snow and frost to prevent corrosion and paint deformations.

Keep the condensing boiler room clean and free of solid volatile substances, which could be sucked into the fan and clog the internal boiler or combustion air ducts.



Every **6-12** months, after first commissioning of boiler, the boiler devices should be cleaned with protective chemicals to prevent calcification and resultant blocking and corrosion on the metallic surfaces.



### **Flushing;**

On the Currently operating systems, appropriate chemical solution with the pH range of 4-6 should be selected for cleaning the pipeline installation for safety commissioning the condensing boiler.

In the new building installations and boiler heat exchangers, maintenance should be applied with chemicals with neutral pH (neutral) effect and preventive maintenance must be carried out periodically.

## 2. TERMS OF WARRANTY

Main and auxiliary equipment and all components used in ECODENSE FT-SS 250, ECODENSE FT-SS 350, ECODENSE FT-SS 450, ECODENSE FT-SS 550, ECODENSE FT-SS 650, ECODENSE FT-SS 750, ECODENSE FT-SS 850, ECODENSE FT-SS 950, ECODENSE FT-SS 1050, Condensing Boilers are guaranteed for 1 year by **TERMO ISI SİSTEMLERİ A.Ş.** starting from the date of commissioning under the maintenance, adjustment, operating conditions and relevant mechanic, chemical and thermal effects explained herein.



Please note that this warranty is only valid if the device(s) is commissioned and maintained by our authorized services.



Our company reserves the right to make any modifications on the product and all instructions thereof for improvement purposes.

### 2.1. Out of Warranty Conditions

- Any damage arising out of or in relation to customers' non-compliance to their responsibilities with regards to installation, commissioning, operation and maintenance,
- Any damage arising out of or in relation to commissioning, repairs and maintenance carried out by unauthorized services,
- Any damage that may occur during transportation or storage of the product,
- Not preserving the product in its original packaging until the installation stage,
- Incorrect and poor electrical connections, Failures due to incorrect voltage applications, frequent repetition of voltage fluctuations,
- Any damage that may occur as a result of incorrect fuel usage or, foreign substances in the fuel used or using of the product without any fuel,
- Any damage that may occur due to foreign particles entered into the product during installation and operation,
- Failures due to incorrect device selection,
- Any damage to unit due to natural disasters,
- Devices without any warranty certificates,
- Warranty Certificates without the stamp and signature of the authorized dealer or service,
- Devices with any falsification on the warranty certificate or without an original serial number.
- The risks during transportation of device under the responsibility of customer belong to the customer.
- Presence of misuse faults are indicated in the reports issued by authorized service stations or our authorized agent, dealer, representative or our factory in case of unavailability of authorized service stations.
- Customers may apply consumer protection arbitrator committee with regards to this report and request for an expert report.

### **3. GENERAL CHARACTERISTICS OF CONDENSING BOILER**

ECODENSE FT-SS 250, ECODENSE FT-SS 350, ECODENSE FT-SS 450, ECODENSE FT-SS 550, ECODENSE FT-SS 650, ECODENSE FT-SS 750, ECODENSE FT-SS 850, ECODENSE FT-SS 950, ECODENSE FT-SS 1050, are heating devices operating with natural gas with a very low suction power, and equipped with high-duty, premix condensing control system with micro-processor. The boiler is composed of a stainless steel heat exchanger and a steel premix burner equipped with ignition and ionization flame control, modulating fan and gas valve. ECODENSE FT-SS 250, ECODENSE FT-SS 350, ECODENSE FT-SS 450, ECODENSE FT-SS 550, ECODENSE FT-SS 650, ECODENSE FT-SS 750, ECODENSE FT-SS 850, ECODENSE FT-SS 950, ECODENSE FT-SS 1050, are designed for use as standalone as well as cascade.

The structure of cascade to be formed by the product group increases the usability in collective housing and individual building applications with its efficient composition.

#### **3.1. Usage of CASCADE**

Premix condensing technology is used in ECODENSE FT-SS 250, ECODENSE FT-SS 350, ECODENSE FT-SS 450, ECODENSE FT-SS 550, ECODENSE FT-SS 650, ECODENSE FT-SS 750, ECODENSE FT-SS 850, ECODENSE FT-SS 950, ECODENSE FT-SS 1050, wall type condensing boilers in order to reach higher efficiency and energy-saving. With suitable connections and approval from gas distribution companies, ECODENSE FT-SS 250, ECODENSE FT-SS 350, ECODENSE FT-SS 450, ECODENSE FT-SS 550, ECODENSE FT-SS 650, ECODENSE FT-SS 750, ECODENSE FT-SS 850, ECODENSE FT-SS 950, ECODENSE FT-SS 1050, boilers can be connected as much as required capacity. Maximum operation pressure of these boilers is 6 bar. Circulation pump, expansion tank and safety valve are not present in these boilers. These are required to be provided by customer and are mandatory to use.



**3.2. ECODENSE Components**

ECODENSE FT-SS 250, ECODENSE FT-SS 350, ECODENSE FT-SS 450, ECODENSE FT-SS 550, ECODENSE FT-SS 650, ECODENSE FT-SS 750, ECODENSE FT-SS 850, ECODENSE FT-SS 950, ECODENSE FT-SS 1050

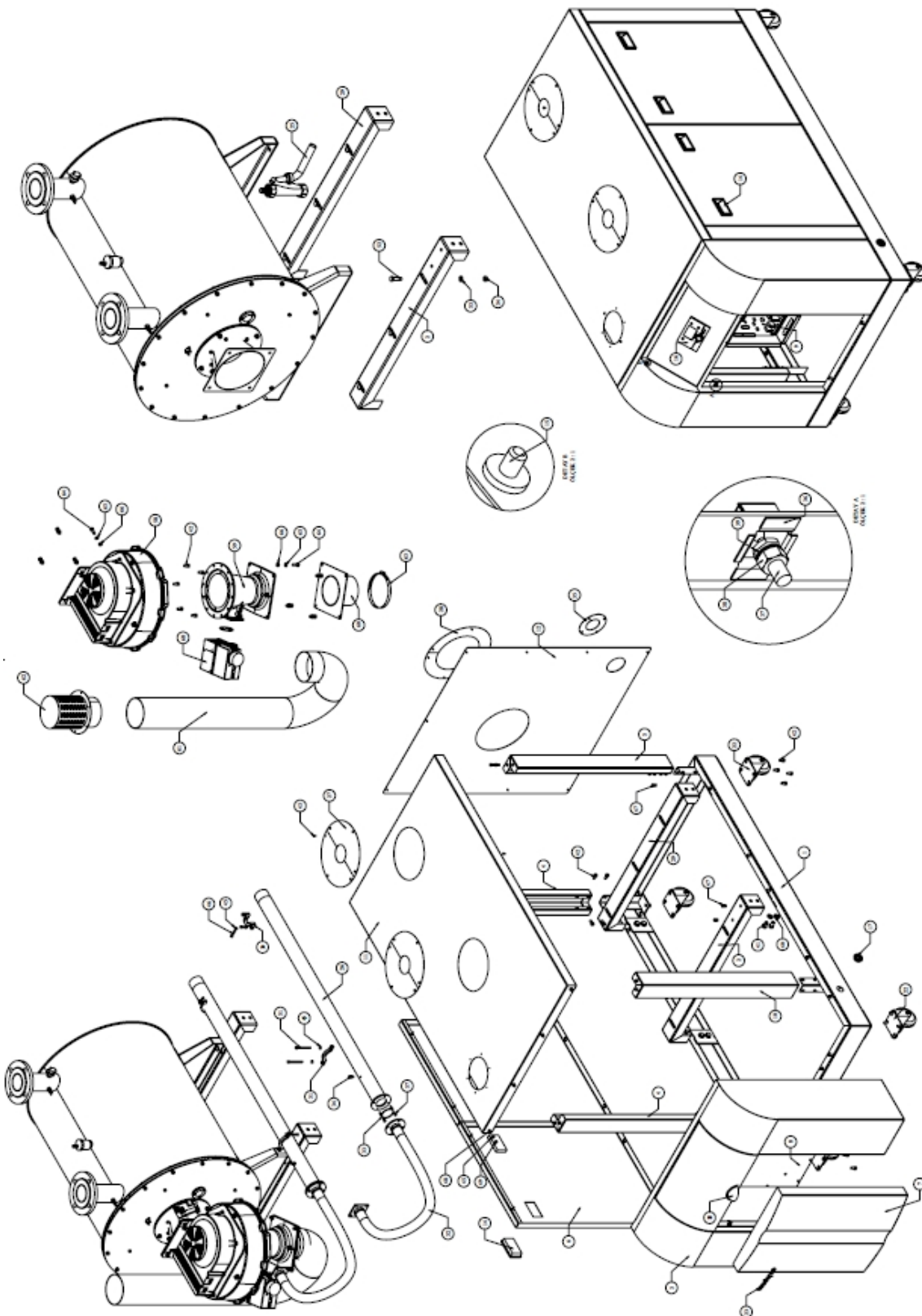

NO	PART NAME
1	CHASSIS
2	UPGRADE SHEET
3	FRONT CONSOLE
4	RIGHT FOOT
5	BACK LEFT FOOT
6	SIDE COVER
7	FRONT COVER
8	CONTROL UNIT PROTECTION SHEET
9	CONTROL UNIT
10	FRONT LEFT FOOT
11	UPPER COVER
12	BACK COVER
13	CONTROL UNIT PROTECTION COVER
14	HANDLE
15	CONCEALED HINGE
16	DISPLAY
17	PLASTIC CAP
18	HANDLE
19	ECODENSE TAG
20	ECODENSE TAG
21	ECODENSE TAG
22	WHEEL
23	ECODENSE TAG
24	STAINLESS STEEL HEAT EXCHANGER
25	CONDENSATE SIPHON
26	GAS INLET PIPE
27	WATER OUTLET COVER
28	FLUE OUTLET COVER
29	UPGRADE SHEET
30	PIPE CLAMP 2"
31	PIPE CLAMP 2"
32	FLEXIBLE HOSE 1 1/4"
33	ORING
34	PURGER

NO	PART NAME
35	GAS INLET COVER
36	METAL DOOR LOCK
37	METAL DOOR LOCK PIN
38	NUT M 5
39	SPRING WASHER M 5
40	WASHER M 12
41	BOLT M 12X20
42	BOLT M 8X16
43	SCREW 0 3.9X9.5
44	SCREW 3,9X9,5(DIN 7504N)
45	WASHER M 6
46	BOLT M 6X30
47	M6 RIVET NUT
48	BOLT M 6X16
49	NUT M 6
50	RIVET 3X6
51	BOLT M 6X70
52	BOLT M 10X40
53	WASHER M 10
54	NUT M 10
55	TRANSFORMER ASSEMBLY SHEET
56	TRANSFORMER
57	BOLT M 5X12
58	FAN
59	VENTURI
60	AIR INLET PIPE
61	SPIRAL ELASTIC HOSE
62	AIR INLET ADAPTER
63	CLAMP
64	BOLT M 8X25
65	WASHER M 8
66	NUT M 8
67	SCREW 0 3.9X6.5
68	VENTIL
69	ORING

#### 4. CONDENSING BOILER GAS, FLUE GAS AND HEATING WATER SCHEMA

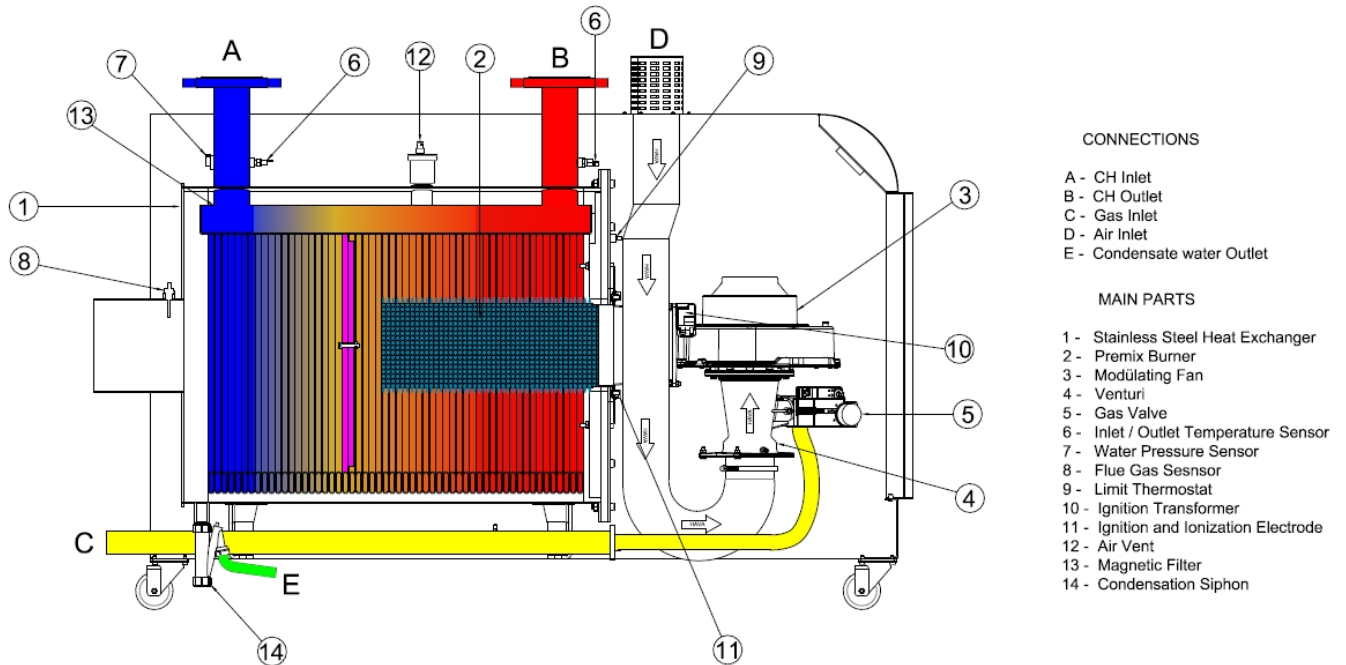

## 5. CIRCUIT SCHEMES

- SENSORS and MODULES**
1. Outside Sensor ( QAC34 )
  2. Temperature Sensor ( QAD36 )
  3. Room Thermostat ( Optional )

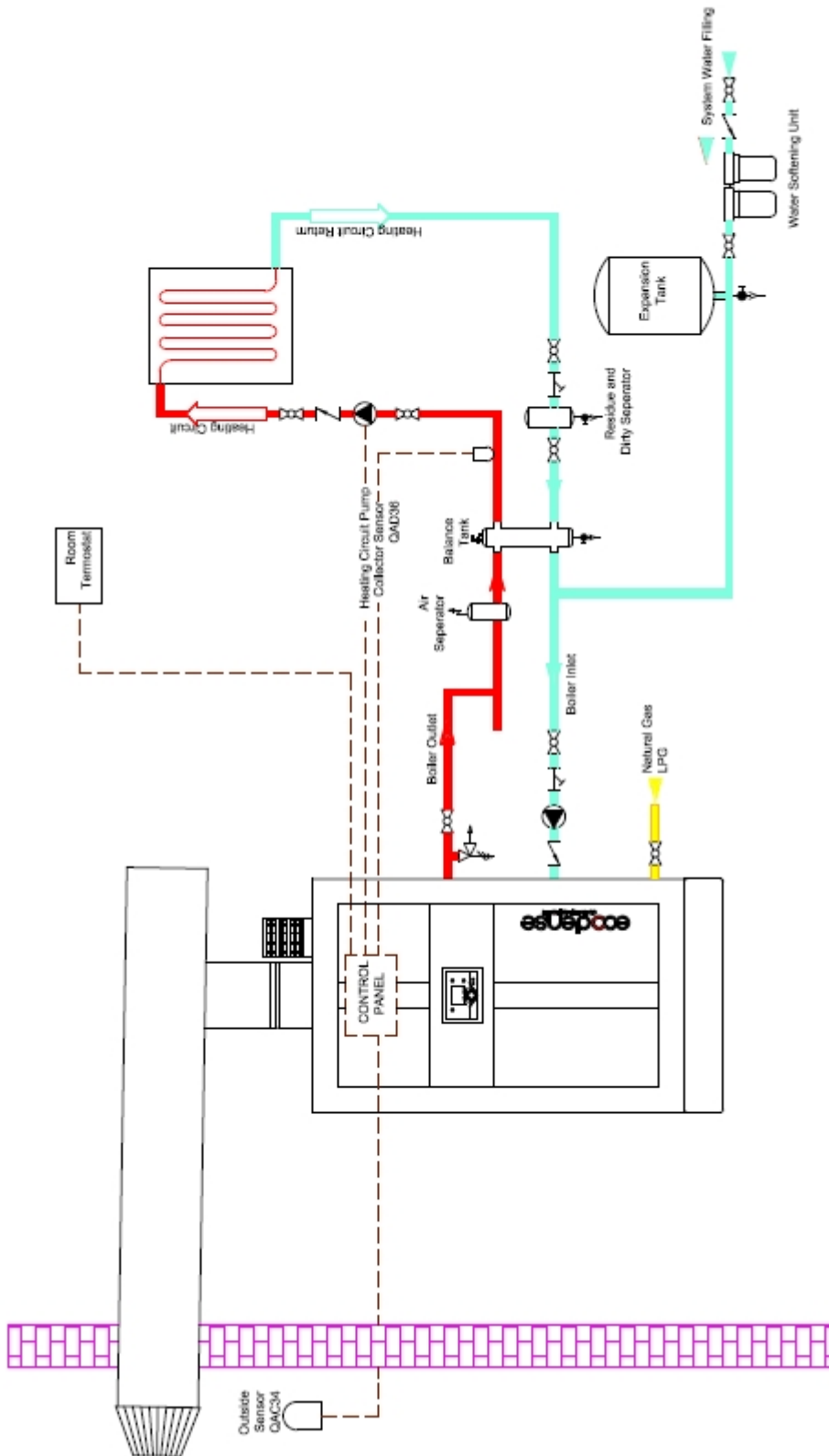

## 6. BOILER WATER FLOW TABLE

The required water flow table for all boiler models is as follows.

<b>Model</b>	<b>Capacity [ kW ]</b>	<b>Water Flow [ m<sup>3</sup>/h ]</b>
FT-SS 250	300	12,9
FT-SS 350	420	18,1
FT-SS 450	480	20,6
FT-SS 550	600	25,8
FT-SS 650	720	31,0
FT-SS 750	900	38,7
FT-SS 850	1040	44,7
FT-SS 950	1210	52,0
FT-SS 1050	1310	56,3

While selecting the boiler pump, it should be determined according to the water flow in the table. Otherwise, the boiler will be considered out of warranty.

## 7. CLOSED CIRCUIT COMPONENTS

### 7.1. Balance Tank

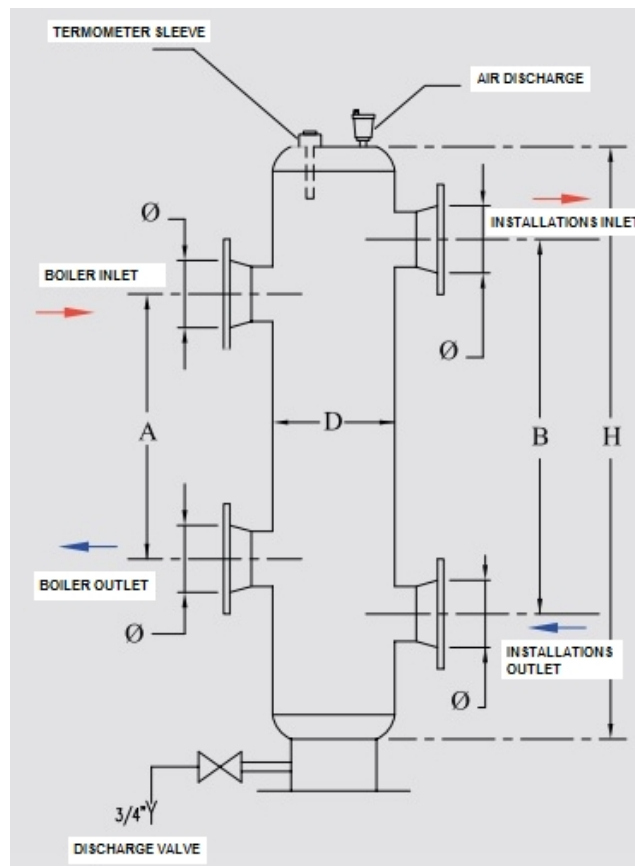

Balance Tank (Separator) must be vertical.

#### Advantages:

- Ø No hydraulic response occurs between the boiler circuit and the heating circuit.
- Ø Boilers and heating zones operate under suitable water flow.

#### Sizing of Balance Tank:

- Ø In order to ensure healthy operation of the balance tank, accurate sizing must be made.
- Ø The boiler's exit water temperature should be measured on the upper part of balance tank.
- Ø For this, a 1/2" muff should be welded onto tank, and also an air relief cock should be mounted.
- Ø Dimensions shown in the picture represent minimum dimensions required to be applied.

## 7.2. Sizing Table For Expansion Tank

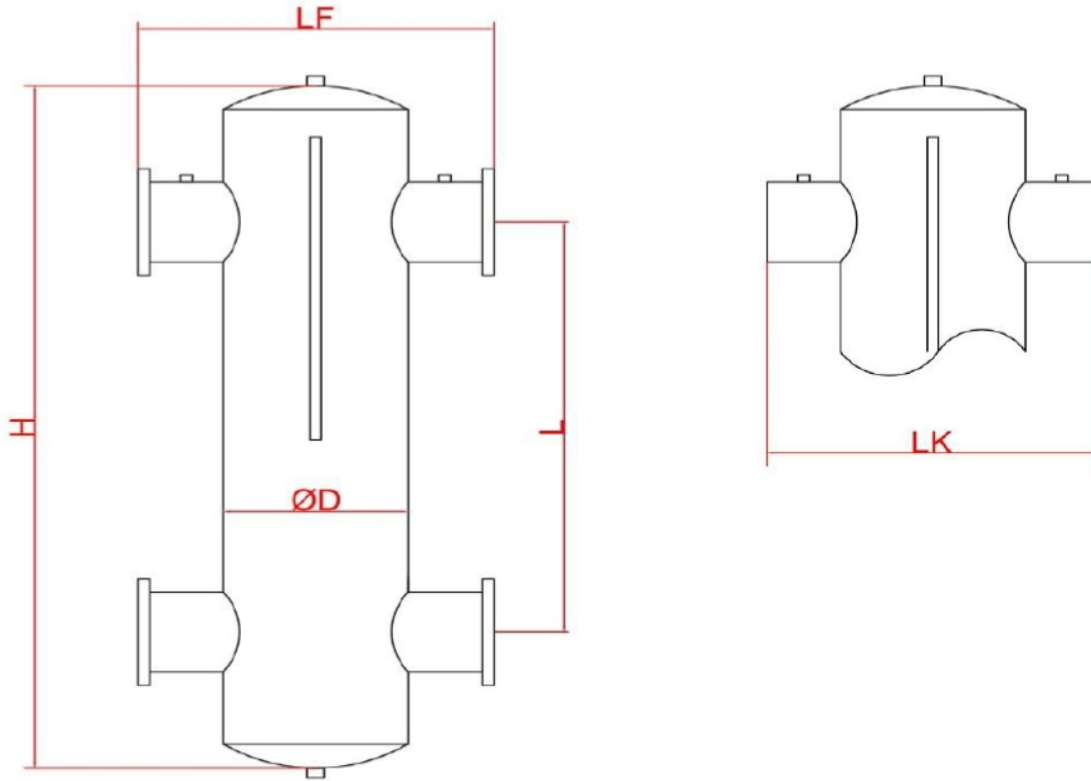

Capacity	Connection Diameter	Dimension					
			ØD	H	L	LF	LK
kW	DN	İnç	DN	mm	mm	mm	mm
1--20	25	1"	65	450	270	265	235
21-29	32	1 1/4"	65	450	270	275	235
30-43	40	1 1/2"	80	480	300	285	245
44-70	50	2"	100	600	350	320	285
71-140	65	2 1/2"	150	720	400	390	360
141-210	80	3"	200	940	500	445	415
211-350	100	4"	200	940	500	445	415
351-550	125	5"	250	1160	600	505	465
551-900	150	6"	300	1380	700	590	550
901-1750	200	8"	400	1840	1000	650	610
1751-3250	250	10"	500	2130	1250	920	860
3251-5250	300	12"	600	2420	1660	1010	960

### 7.3. Expansion Tank



Expansion tank fore pressures must be adjusted according to system. Expansion tank should be placed parallel to circuit return line.

### 7.4. Manometer

A manometer with capacity of at least 0 to 6 bar must be connected to system. Manometer should be placed to easily visible spot from filling point, preferably same point as expansion tank.

### 7.5. Strainer

Any dirt or residue in circuit water causes damage got boiler and circuit components and decreases efficiency by reducing heat transfer. In order to prevent this problem a strainer must be connected to circuit.

### 7.6. Air Separator

The air in the water dissolves due to increasing temperature and flow in the circuit. Dissolved air causes cavitation, sound and efficiency loss. By using an air separator air is removed from the system.



The hydraulic system design must comply with the circuit diagrams specified in the user manual to ensure that the system operates smoothly and that installation errors do not result in loss of efficiency. The hydraulic system must have a balance vessel, sediment trap, air separator and expansion tank in accordance with the system capacity and specifications.



In order to keep the pH value in balance, passing the water circulating in the system through a softening step (Reverse osmosis systems) will be useful in the continuity of the water quality.



## 8. WATER QUALITY

1. Before connection of condensing boilers any dirt and residue in circuit must be cleaned.
2. Water Hardness and pH measurements should be made by the authorized or central service in the field where the boiler will be commissioned before the commissioning, and it should be decided whether the water can be used in the boiler water installation.
3. Refined water must be used while adding water to heating circuit due to any loss in closed circuit.
4. Permitted water hardness for the water used in water circuit must comply with French or German (VDI 2035) hardness degree standards. The lime dissolved in water, settles on hot surfaces and forms an insulation layer when water temperature rises. This prevents heat transfer and high temperature might damage the heat exchanger. If boiler water cycles through water circuit, all circuit water must meet above requirements. If a plate heat exchanger separates boiler water and heating circuit water, only the water between boiler and heat exchanger must meet these requirements.

In order to prevent sedimentation, properties of the water to be used or to be reinforced in the water line should not exceed the following table values according to below mentioned capacities.

Boiler Type	Capacity	(Total Hardness)		
		ppm	(°F) French	VDI German
Single Boiler	0-50 kW	250	< 25	< 14
Single Boiler	50-200 kW	110	< 11	< 6,16
Single Boiler	200- 600 kW	40	< 4	< 2,24
Single / Cascade	>600 kW / All capac.	2	< 0,2	< 0,112

\*Volume to capacity ratio of water in circuit must be higher than 20 l/kW. Total volume of first filled water and additional water must be less than volume of system.

5. The customer or contract company should analyze the water to be used in the water line by an accredited organization prior to commissioning and a water quality report should be provided containing Minimum Hardness, pH and conductivity values, total dissolved solid values .
6. **pH value of unrefined water must be 7<pH<9. This pH value can be achieved after filling the circuit with main circuit water with pH value of 7 and air separation. pH value of refined water must be between 7-8,5 pH.**
7. In new building installations, periodic preventive maintenance must be carried out by using organic solutions with a chemical pH effect [neutral].
8. Prior to commissioning of condensing boilers in old building water installations, a suitable type of organic solution with a pH value (acidic) between 4 and 6 should be washed.
9. The boiler water pipeline and heat exchanger should be treated with a suitable type of organic solution over a period of 6 to 12 months to prevent calcification and deposits that may occur over time in the installation.
10. If the water quality is outside the value ranges given above, it is mandatory to use a water softening filter or electrolytic limescale reducer in the system for water installations.

## 9. TECHNICAL DATA

### 9.1. Capacity Table

<b>ECODENSE <i>FT - SS SERIES</i> WALL TYPE CONDENSING BOILER</b>										
TECHNICAL SPECIFICATIONS	Unit	FT-SS 250	FT-SS 350	FT-SS 450	FT-SS 550	FT-SS 650	FT-SS 750	FT-SS 850	FT-SS 950	FT-SS 1050
<b>Thermal Capacity</b>										
Maximum Heating Capacity	kW	250	350	450	550	650	750	850	950	1050
Minimum Heating Capacity	kW	56,3	75	89	114	110	125	135	146	150
Maximum Heat Output (80°C / 60°C)	kW	243,1	341	440,6	534,7	632,8	730	827,5	924,8	1023
Minimum Heat Output (80°C / 60°C)	kW	55	73,4	86,6	111,5	107,7	122	132,0	142,5	146,5
Maximum Heat Output (70°C / 50°C)	kW	253,2	355	458	557	659	760	861	963	1065
Minimum Heat Output (70°C / 50°C)	kW	57,7	77	91	117	113	128	139	150	154
Maximum Heat Output (50°C / 30°C)	kW	263,2	369,2	475,0	578,8	685,7	790,1	895	1000,8	1106,5
Minimum Heat Output (50°C / 30°C)	kW	60,4	80,6	95,6	122,5	118,5	134,7	145,2	157	161,4
<b>Thermal Efficiency</b>										
Efficiency @ Pmax. (80°C / 60°C)	%	97,2	97,3	97,9	97,2	97,4	97,3	97,4	97,3	97,4
Efficiency @ Pmin. (80°C / 60°C)	%	97,7	97,8	97,3	97,8	97,9	97,6	97,8	97,6	97,7
Efficiency @ Pmax. (70°C / 50°C)	%	101,3	101,4	102	101,2	101,4	101,3	101,3	101,3	101,4
Efficiency @ Pmin. (70°C / 50°C)	%	102,5	102,6	102,4	102,6	102,8	102,7	102,7	102,6	102,6
Efficiency @ Pmax. (50°C / 30°C)	%	105,3	105,5	105,6	105,2	105,5	105,3	105,3	105,3	105,4
Efficiency @ Pmin. (50°C / 30°C)	%	107,3	107,5	107,4	107,5	107,7	107,8	107,6	107,5	107,6
Efficiency @ %30 (30°C)	%	108,1	108,2	108,3	108,3	108,4	108,2	108,2	108,3	108,1
<b>Domestic Hot Water Circuit</b>										
Temperature adjustment range with external storage tank usage	°C	10-65	10-65	10-65	10-65	10-65	10-65	10-65	10-65	10-65
<b>Central Heating Circuit</b>										
Maximum Operating Temperature	°C	85	85	85	85	85	85	85	85	85
Maximum Operating Pressure	bar	6	6	6	6	6	6	6	6	6
Minimum Operating Pressure	bar	1	1	1	1	1	1	1	1	1
Water Resistance $\Delta T = 20^\circ C$	mbar	250	260	260	280	270	280	300	290	310
<b>Gas Specifications</b>										
Gas Type	-	G20-G31	G20-G31	G20-G31	G20-G31	G20-G31	G20-G31	G20-G31	G20-G31	G20-G31
Gas Inlet Pressure (G20)	mbar	20	20	20	20	20	20	20	20	20
Gas Inlet Pressure (G31)	mbar	37	37	37	37	37	37	37	37	37
Maximum gas consumption	Nm <sup>3</sup> /h	26,06	36,48	46,91	57,33	67,76	78,18	88,61	99,03	109,45
Minimum gas consumption	Nm <sup>3</sup> /h	5,87	7,82	9,28	11,88	11,47	13,03	14,07	15,22	15,64
<b>Combustion Specifications</b>										
Maximum Flue Gas Temperature (50°C / 30°C)	°C	52,4	52,6	54,7	55,2	55,3	55,7	56,2	57,5	57,1
Maximum Flue Gas Temperature (70°C / 50°C)	°C	62,1	62,4	64,5	64,6	64,9	65,4	65,9	67,5	68,8
Maximum Flue Gas Temperature (80°C / 60°C)	°C	69,4	72,1	74,6	74,2	74,5	75,1	75,6	78,2	79,5
NOx Emission Class (EN 15502-1+A1)	-	6	6	6	6	6	6	6	6	6
<b>Electrical Specifications</b>										
Electrical Supply	V / Hz	230/50	230/50	230/50	230/50	230/50	230/50	230/50	230/50	230/50
Protection Class	IP	X4D	X4D	X4D	X4D	X4D	X4D	X4D	X4D	X4D
Energy Consumption	W	260	280	350	400	520	600	670	750	840
Fuse Current	A	6	6	6	6	6	6	6	6	6
<b>Circuit Specifications</b>										
Gas Connection Diameter	inch	1 1/2"	1 1/2"	2"	2"	2"	2"	2"	2"	2"
Central Heating Circuit Inlet/Outlet Diameter	inch	2"	2"	2 1/2"	2 1/2"	2 1/2"	2 1/2"	2 1/2"	2 1/2"	2 1/2"
<b>General Specifications</b>										
Net Weight	kg	200	222	255	291	351	455	525	612	667
Flue Diameter (Ø)	mm	160	160	200	200	200	200	200	200	200
G 20 Natural Gas, G 31 LPG										

## 9.2. Condensing Boiler Dimensions

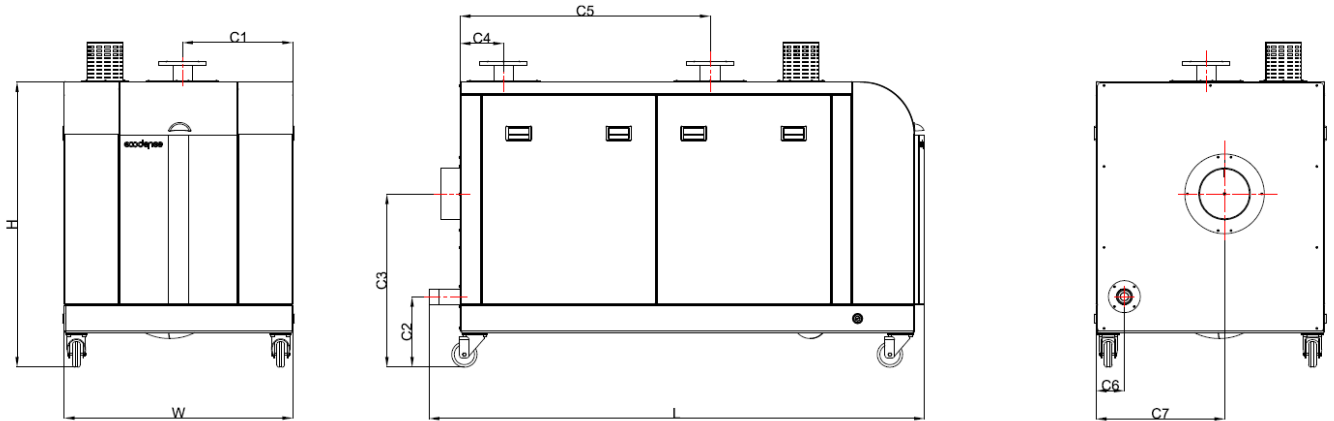

MODEL	W (mm)	H (mm)	L (mm)	C1 (mm)	C2 (mm)	C3 (mm)	C4 (mm)	C5 (mm)	C6 (mm)	C7 (mm)
FT-SS 250	750	975	1400	375	270	605	160	533	104	431
FT-SS 350	750	975	1600	375	270	605	160	710	104	431
FT-SS 450	750	975	1850	375	270	605	160	890	104	431
FT-SS 550	890	1115	1800	430	275	675	170	840	110	500
FT-SS 650	890	1115	1930	430	275	675	170	975	110	500
FT-SS 750	890	1115	2065	430	275	675	170	1110	110	500
FT-SS 850	890	1115	2200	430	275	675	170	1245	110	500
FT-SS 950	890	1115	2335	430	275	675	170	1380	110	500
FT-SS 1050	890	1115	2470	430	275	675	170	1515	110	500

- Prevent strong impacts on top of the product and vibration while handling the product.
- Do not leave the product in wet environment.



Clean the inside of fuel line thoroughly before installing the burner to the fuel line. Any damage that may occur due to solid objects and metal particles from the fuel line shall not be covered by our company.

## 9.3. Noise Level

When the condensing boiler is in operation, the maximum noise level released is <70 dBA. The noise level value corresponds to the value measured with semi-anechoik (semi-unreflecting acoustic) room testing according to the product standards at the time of expansion of the smoke release system, when the condensing boiler operates at the maximum heating power.

## 10. INSTALLATION

### 10.1. General Controls

- Ø The heating capacity of the device should be determined based on the heat requirement calculated.
- Ø All parts necessary for the system must be available.
- Ø Make sure that all protection and safety devices are available.
- Ø In order to prevent accumulation of dirt in the system, prevention of boiler operation and damage given to the boiler by clogging, a filter must be mounted onto the system's return pipe.
- Ø The device is equipped with a freezing protection system to switch the device to the heating mode when the temperature of distribution water drops below + 4 °C.
- Ø Ensure that the gas connections are made with pipes confirming to the standards, and that there is no leakage on these connections.
- Ø Ensure that the electric connections are proper.



During cascade installation, do not forget to mount an external gas cut-off valve suitable to the devices.

### Electrical Connection



Perform electrical connections according to the diagram provided. Follow general security rules during installation of electric wiring and making connections. Connect the earthing terminal in electric panel to the earthing installation.

### 10.2. External Outdoor Sensor (Optional)

Connect the sensor to the relevant terminal. The length of electric cable for external sensor connection is max. 25 m. A 2x1.5 cable should be used. The sensor must not be exposed to the morning sun and if possible, to direct sunlight. Since the values to be read by the sensor will be affected, it must not be mounted close to any window, door, vent hole and heat sources.

#### Unsuitable places to mount external sensor;

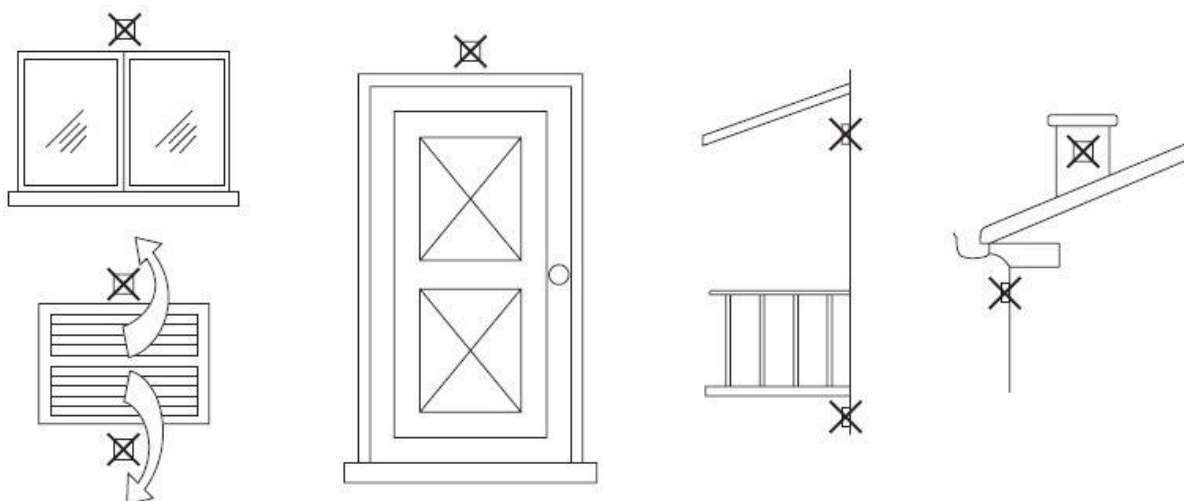

## 11. STACK CONNECTIONS

1. Horizontal stack extensions must be connected to boiler at 1.5°-3° angle in order to drain condensing fluid.
2. Stack setup must be according to local ventilation conditions.
3. Stack connections must be leak proof.

Some examples of stack setup can be seen below:

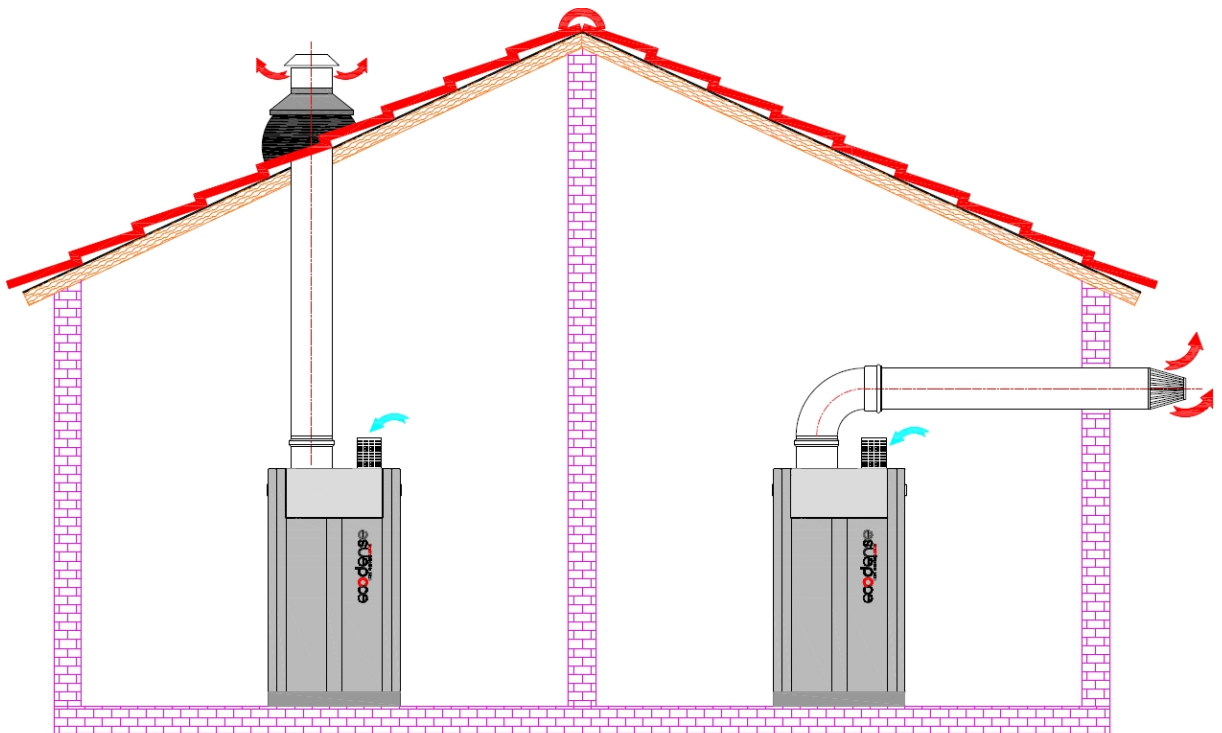

According to the EN 13501-1 8.102.2.7 clause, all the materials used in the boilers are in the Reaction to Fire limit Class F.



The combustion products discharge materials used in the boiler have 0 (zero) heat resistance according to the EN 13501-1 8.102.1 clause.

## 12. ASSEMBLY

### 12.1. ECODENSE Assembly Instructions

ECODENSE condensing boilers are designed to work as CASCADE; they are compatible for side by side or back to back operation. They provide suitable space utilization for every stakeholder design at required capacities.

### 12.2. ECODENSE Single/CASCADE Assembly Instructions

1. Mount the boiler to wall by using assembly equipment shipped with your boiler.
2. 500 mm of gap between boilers is advised.

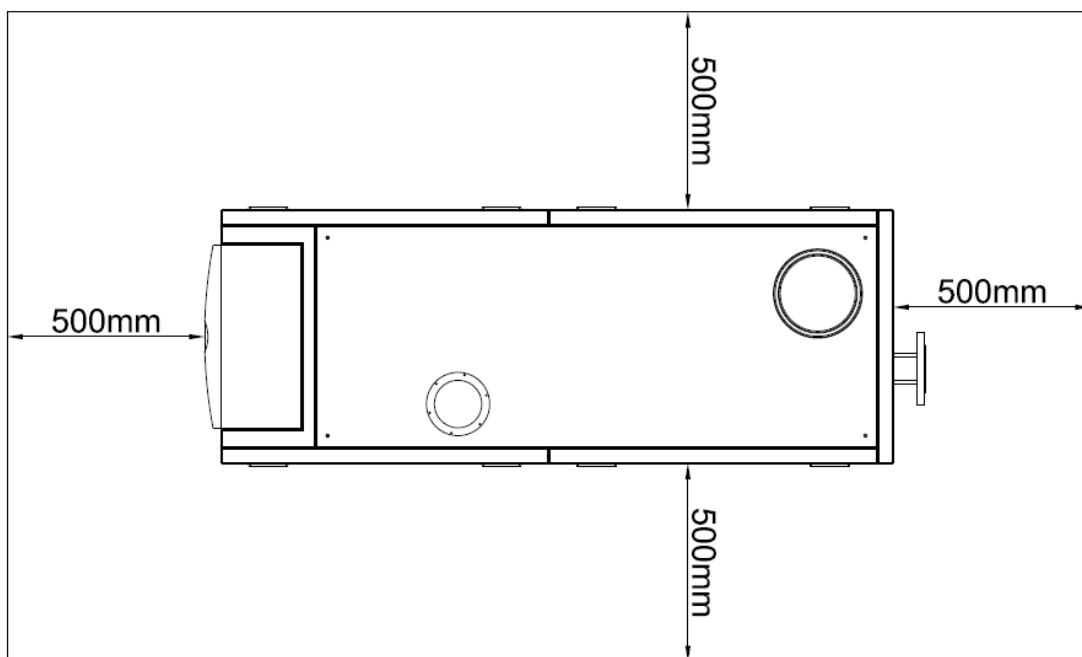

**i** There must be at least 500 mm of gap between adjacent boilers and at least 500 mm of space in front of the boiler for ease of service.

### 12.3. Assembly of Condensing Fluid Drain

1. Ensure that siphon is fully filled with water before activation of boiler.
2. Drain direction must allow flow of condensing fluid. Drain pipe must be planned to prevent any clogging due to external effect like frost, etc. Drain parts must be plastic.
3. Boiler condensing outlet must be at least 19mm.

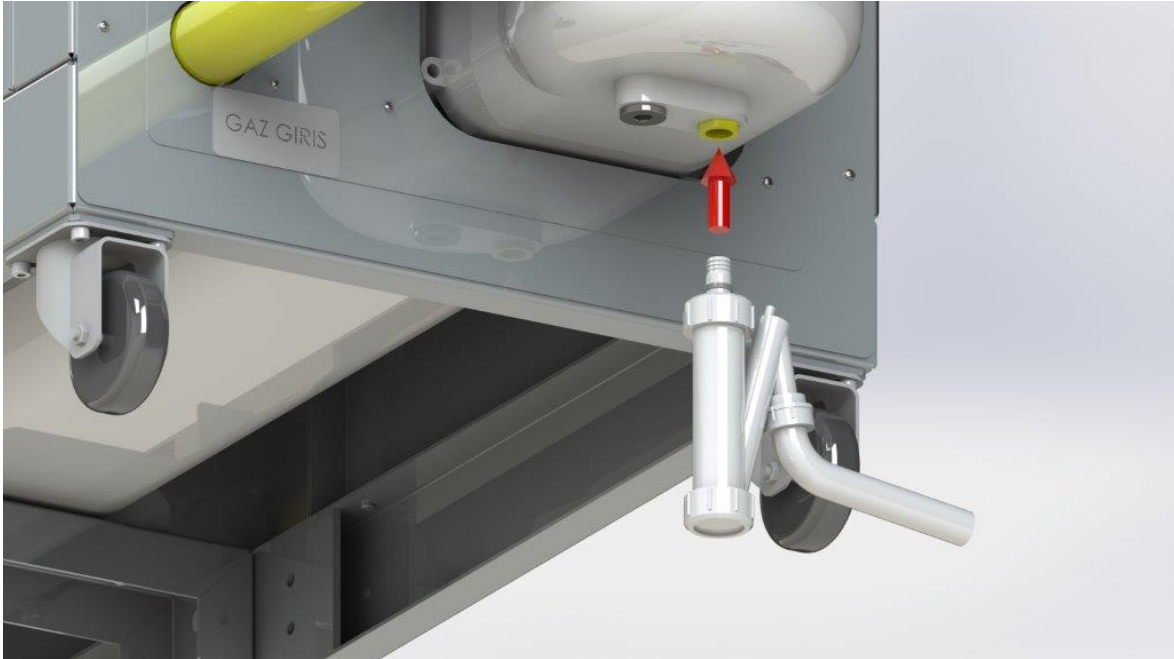

Condensing drain must not be changed or clogged after assembly. Clogging of condensing drain causes the boiler to automatically shut down or causes the syphon to overflow. It will be helpful to pour some hot water to the open parts of drain if there is a possibility of frost. Drain must be open at all times to ensure proper functioning of the boiler.



Condensing Water Syphon should be cleaned from dust and dirt in every 3 months and also beginning of every winter.

### **13. ECODENSE CONTROL INSTRUCTIONS BEFORE START-UP**

1. Ensure that boilers are mounted on fixed, firm and robust wall. Use metal hangers on improper walls.
2. Ensure that every boiler has connected to their own 6A fuse.
3. Maximum operation pressure is 6 bars in the closed circuit. Ensure that in CASCADE SYSTEMS, Balance tank is used below 6 bars and plate heat exchanger is used above 3 bars. In situation where plate heat exchanger is used, Expansion tanks with proper capacities must be used at both outgoing and return lines.
4. In single or CASCADE applications, safety valve fixed to 6 bars must be used. Adjustable safety valve must not be used. As a minimum requirement of the system, use the safety valve as shown in the package/hydraulic schematic.
5. Control the sufficiency of capacity of circulation pump used in primer circuit (between boiler and balance tank).
6. In single and cascade type condensing boiler systems, flue pipe connections should be assembled in a compatible direction and angle and also in a sealed manner according to the boiler condensate outputs. Chimney connections must be made in the form of air suction or hermetic chimney connection directly from the environment in accordance with the standard rules.
7. Ensure that there are components such as automatic air vent, air separator and dirt/sediment retainer on the system and that it is used in sufficient volume and quantity according to the scheme for the relevant installation model.
8. A manometer to monitor system pressure must be present in system, control if it is mounted on the system.
9. Control if the condensing fluid siphon is made of plastic, isolated against frost, at correct radius and connected to condensing fluid drain with an angle. It should not be connected to rain drain.
10. Ensure that circuit and system are tested against leakage and system pressure is sufficient.
11. Ensure that gas pressure complies with boiler operation instructions. In situations where gas pressure is higher than required pressure, a regulator must be used.
12. Ensure that sensors on boiler feed and circuit (outgoing-return temperature, ambient temperature, boiler temperature sensors) are wired correctly. Wires of boiler feed and other equipment on circuit belong to user.
13. Shut-off valve must be installed as safety device on the line where gas pressure is reduced from 300 mbar to 21 mbar pressure by regulator.
14. In boiler installations with 6 or more capacity of 200 kW and higher, depending on design and consumption of the gas line, it must be divided into 2 or more sections and should be installed with the additional regulators.



15. In case of an imbalance in electrical installation's voltage value, It is recommended to install a voltage regulator of 1 kw, up to 550 kw capacity and 2 kw; for capacities over 550 kw in order not to damage the electronic card on the device.
16. In the regions with cold and minus winter conditions, only Propylene Glycol containing Anti-freeze liquid is allowed to use as a frost protection liquid for boilers, Content suitability  
It is advised to interview with the manufacturer about Suitable liquid content.



On first start-up if there is deficiency in the system detected by ECODENSE authorized service technicians, technicians are not allowed to activate the system.



Do not connect the circulation pump as the engine will be above and the engine will be below.

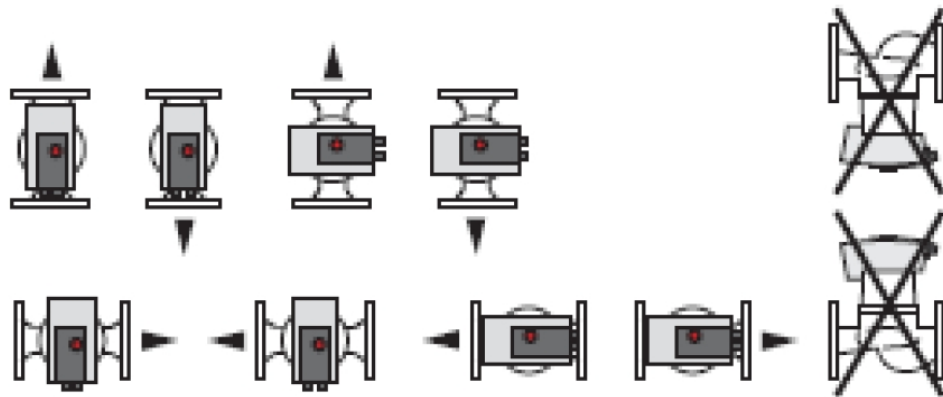

### Cleaning of Water and Gas Line

1. Before the installation of condensing boiler gas lines, the internal surfaces of the gas pipes must be thoroughly cleaned. Damage to the solids, metal particles and contaminants accumulated in the gas line should be considered except for the warranty.
2. During the assembly of newly manufactured water line installations, harmful objects such as metal, slag, stone, sludge, which remain in the pipe, must be washed and emptied before commissioning the boilers.
3. In areas where there is deep water or transportation type water, condensate boilers should not be allowed to be commissioned before the water in the system has passed through a number of processes such as conditioning and softening.
4. In case of obsolete and deformed area and installation conditions where the risk of corrosion is particularly intense and in which the risk of sedimentation is high, it is necessary to ensure effective protection of the boilers after commissioning by adding a magnetic dirt retainer to the water line.

### 14. ELECTRICAL DIAGRAM

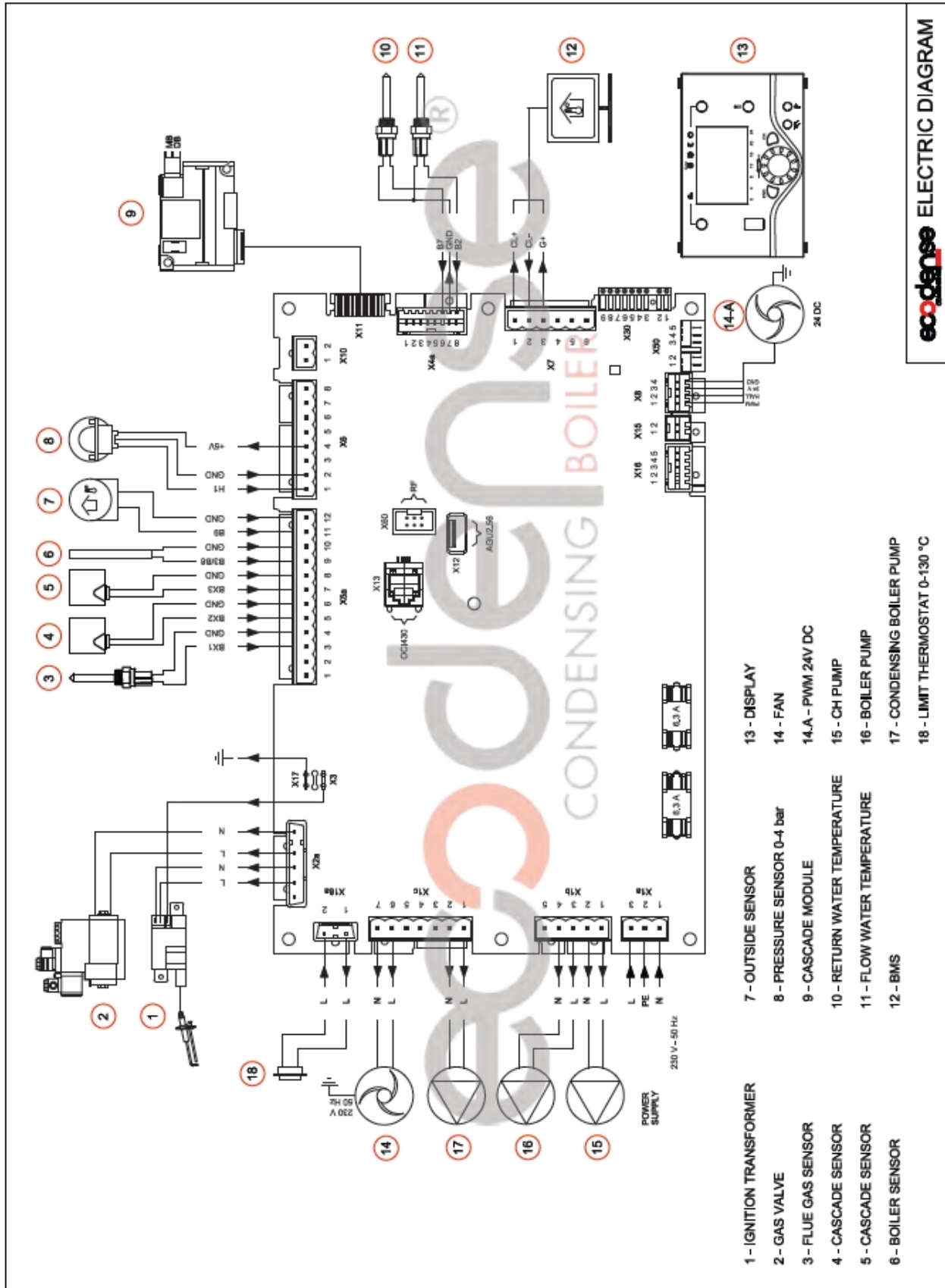

## 15. COMMISSIONING

### 15.1. Before Commissioning

- Ø Open all open/closed valves between the device and systems.
- Ø Check gas connections by using foam and water solution for determining leakages on connections carefully.
- Ø Check the initial pressure of expansion tank.
- Ø Fill the water system.
- Ø You should check that air separator works and cap of automatic air discharge is open while the gas valve is closed.
- Ø First adjust the plumbing pressure proper value (1-3 bar is advised), hold the Manual Mode button down for 5 sec. The deaeration function will be active on the screen. When this function is active, observe that the boiler is performing the aeration process. The circulation pump will circulate the water and air in the system will be purged from automatic air separator. The boiler will start deaerating and this will continue for 10-15 minutes
- Ø Remove the air in radiators.
- Ø Check the air in the system after removing air form radiators.



If there is air in the system repeat the deaeration process.

- Ø Check if the system pressure is over 1 bar. If it is under 1.2 bar there will be a warning on the screen. If it is under 1 bars, system will give an error code (118). In this case check the system pressure and air in the system (If plumbing pressure drops often do not start the boiler without determining the cause and call an authorized service).
- Ø Fill the condensing siphon according to manual before starting the boiler. There is a risk of gas spreading to boiler room while the siphon is empty.
- Ø Ensure that there is no leakage in the water circuits, connections and boiler.
- Ø Make sure that the electrical connections are correct and the grounding is sufficient.
- Ø Check the accuracy of required gas pressure value.
- Ø Make sure that there is no flammable material adjacent to the boiler.



This product has an automatics air separator. While performing filling or first start up operations, be sure that there is no air in the system via air separator or manually.



For automatic water filling, equip the system with proper equipment.

## 15.2. Checks During Commissioning

- Ø Switch on the device.
- Ø Ensure the soundness of oil circuit and water system.
- Ø When the boiler is in operation, check sufficiency of flue and water pipes.
- Ø Check the soundness of condensation system and ensure its correct operation.
- Ø Make sure that water circulation takes place properly.
- Ø Make sure that gas valve is operating correctly.
- Ø Check the eligibility of values at minimum and maximum capacities by using a flue gas analyz
- Ø Check the compatibility of gas consumption with the values on the technical data table.
- Ø Make sure that parameters are programmed correctly.



Connect the communication module (OCI 345) to the point specified in the card box.

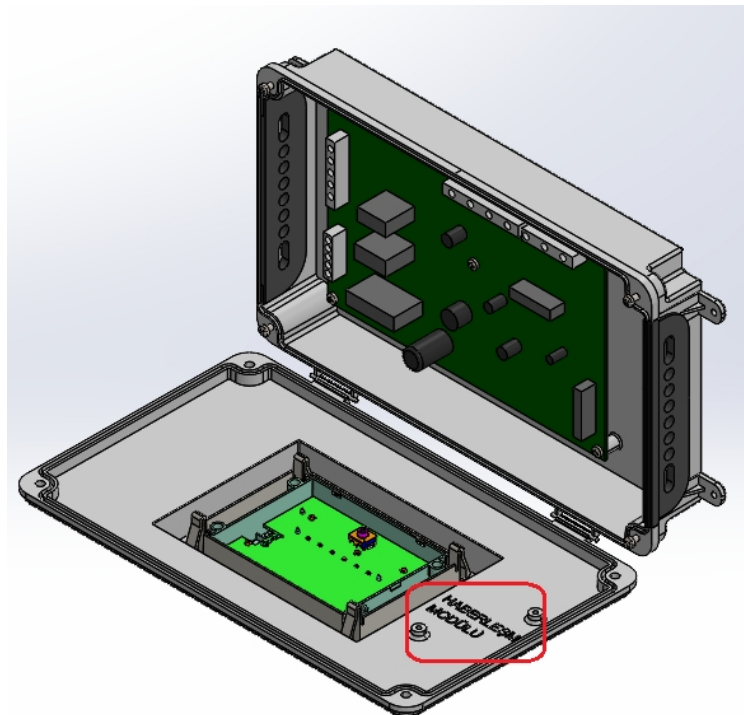

## 16. ADJUSTING COMBUSTION PARAMETERS

Instructions below are specially prepared for ECODENSE service technicians. Before shipment parameters of all the boilers are adjusted at suitable capacity and pressure at factory's test stand. Settings mentioned below are for combustion optimisation at field conditions. Appropriate allen keys and wrenches must be used for screws and caps. Gas and air values must be adjusted by using a flue gas analyser.

### 16.1. Adjustment and Measurement Points

**A:** Max. Adjustment Point

**B:** Min. Adjustment Point

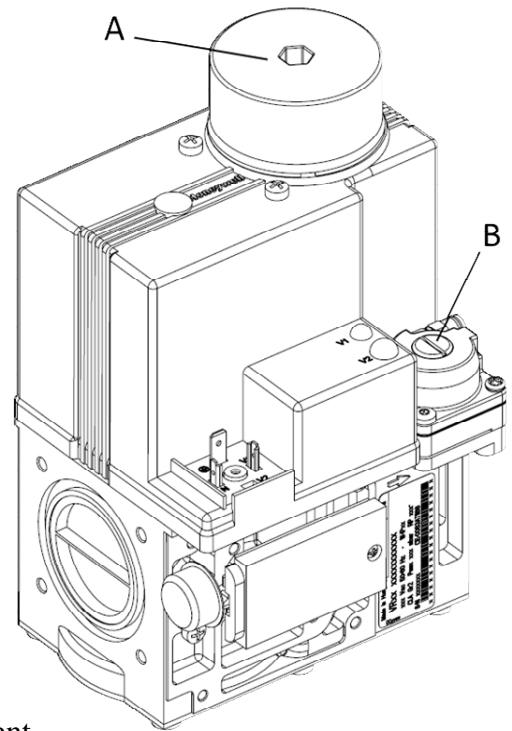

**During adjusting parameters follow below step;**

1. Minimum capacity activation and combustion adjustment
2. Medium capacity emission control
3. Maximum capacity combustion adjustment and control
4. Minimum-maximum capacity combustion adjustment control

## 17. CONTROL PANEL BUTTON SPECIFICATIONS

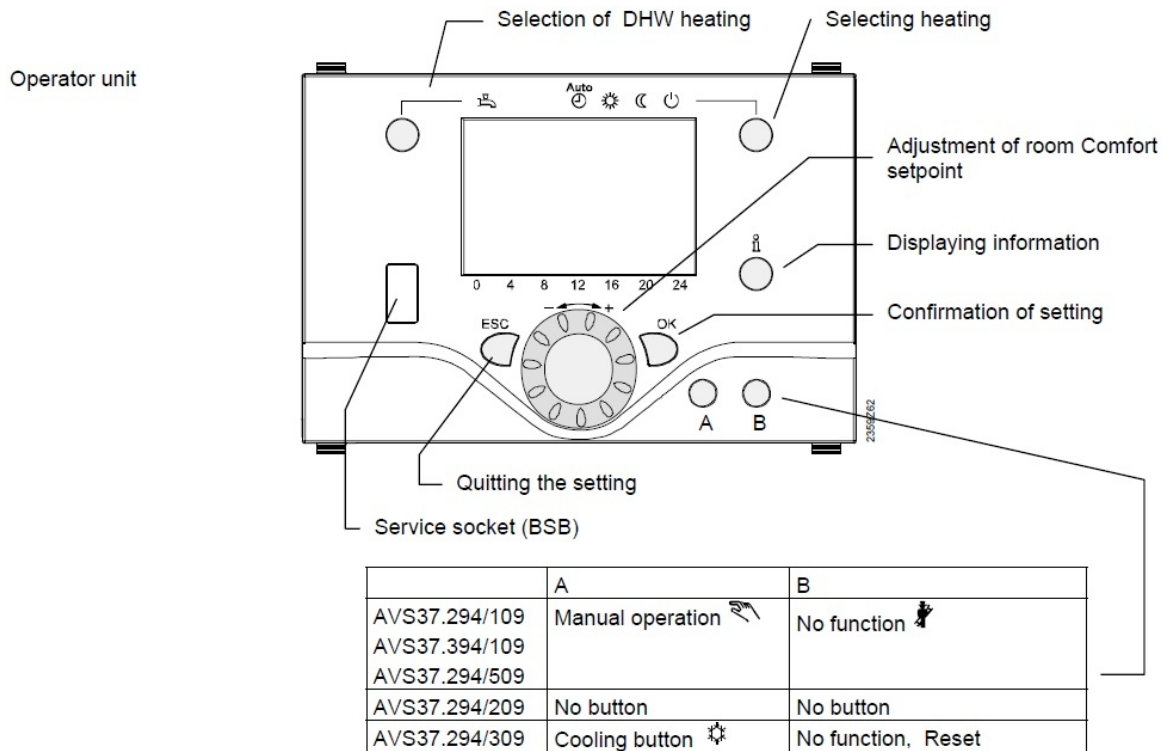

### 17.1. Adjusting Minimum Capacity

1. Connect probe of flue gas analyzer to measurement point.
2. Connect a manometer to the gas feed pressure measurement point and control if the pressure is at suitable value.
3. In order to operate the boiler at minimum capacity activate **cooling mode** via **A** button.
4. Press **selecting heating** button for 4 seconds ("Controller stop function on ") will be seen on the screen, by pressing **Displaying information** button, capacity value can be seen on the screen). Via **Adjusting of room Comfort setpoint** button set boiler capacity to 10%. Later when you press **OK** button, boiler will start working at minimum capacity.
5. According to flue gas measurement values at minimum capacity, use **A** and **C** points for gas flow rate. Use **A** point for coarse setting for gas flow rate and **C** point for precise gas flow rate. **For both points**, turning clockwise increases flow rate and turning counter clockwise decreases flow rate.

### 17.2. Adjusting Medium Capacity

1. Via **Adjusting of room Comfort setpoint** button set boiler capacity to 50%. Later when you press **OK** button, boiler will start working at medium capacity. Control the flue gas values and start adjusting maximum capacity if flue gas values are ok.

### 17.3. Adjusting Maximum Capacity

1. Via **Adjusting of room Comfort setpoint** button set boiler capacity to 100%. Later when you press OK button, boiler will start working at medium capacity.
2. According to flue gas measurement values at maximum capacity, use **A** and **C** points for gas flow rate. Use **A** point for coarse setting for gas flow rate and **C** point for precise gas flow rate. **For both points**, turning clockwise increases flow rate and turning counter clockwise decreases flow rate.

Check the emission values at minimum and maximum capacities again and adjust combustion parameters precisely by following above steps.

After adjustment of parameters are finished, close all measurement points as they will be leak proof.

Flue gas emission values and flue gas temperature limit values are given at below table:

	Min.	Max.
O <sub>2</sub> (%)	4,5-5	5,5-6
CO (ppm)	<250	
CO <sub>2</sub> (%)	8,4-9,5	
Flue Gas Temperature °C	<80	

### 17.4. Adjusting Time Schedule

1. Press ESC button several times in order to get main screen.
2. Press “OK” button when you are at main screen. “Time and day adjustment” line will be seen on the screen. Press “OK” again and select related line.
3. In order of clock, year and month informations will blink.
4. Set the blinking value and press “OK” after each setting.

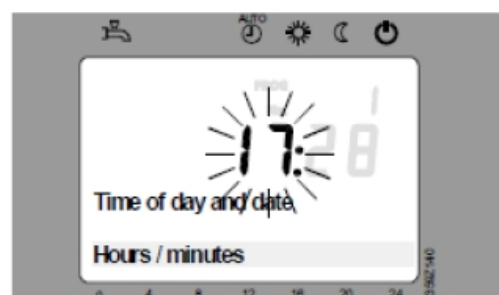
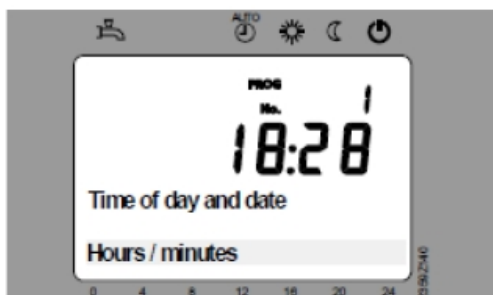

## 18. MAINTENANCE

### 18.1. Monthly Maintenance

Monthly maintenance is a comprehensive process where general checks of condensing boiler and peripheral components are performed to prevent possible faults. After completion of maintenance and adjustment processes, make sure to perform an emission analysis.

- Ø Clean gas and water line filters.
- Ø Perform insulation measurements of ignition and ionization electrodes, replace electrodes should there be leakage to the body.
- Ø Check ignition cables and sockets.
- Ø Check all wiring points. Tighten loose connections.
- Ø Check gas line pressure, it must be the same with the first adjusted pressure, otherwise the boiler load and emission values will also have changed.
- Ø Check all bolts of the boiler. Tighten loose bolts.
- Ø After starting the condensing boiler and making required adjustments, perform flue gas emission measurement and check if there is an ideal combustion.

### 18.2. Seasonal Maintenance

It is a comprehensive maintenance work when the condensing boiler is re-started after long periods of shut-down or interruptions. After completion of maintenance and adjustment processes, make sure to perform a combustion analysis.

- Ø Check ignition and ionization electrodes.
- Ø Check the operating function.
- Ø Check the inlet/outlet water sensors.

 Condensing Water Syphon should be cleaned from dust and dirt in every 3 months and also beginning of every winter.

 Follow installation directions during maintenance.

 Periodic maintenance shortages in condensing boilers can cause carbon monoxide poisoning.



When an operation is performed with the system water pressure, it is necessary to carry out the air removal process due to reasons such as water loss and fill from water installation during seasonal and monthly maintenance.



## 19. LIST OF ERROR CODE

Error Code	LPB Code	Error Description
10		Exterior temperature, sensor error
20		Boiler temperature 1, sensor error
25		Solid fuel boiler temperature, sensor error
26		General flow water temperature, sensor error
28		Flue gas temperature, sensor error
30		Flow water temperature 1, sensor error
31		Flow water temperature 1, cooling, sensor error
32		Flow water temperature 2, sensor error
38		Flow water temperature, main control device, sensor error
40		Return water temperature 1, sensor error
46		Cascade return water temperature, sensor error
47		General return water temperature, sensor error
50		DHW temperature 1 sensor error
52		DHW temperature 2 sensor error
54		Flow water temperature DHW, sensor error
57		DHW, recirculation sensor error
60		Room temperature 1, sensor error
65		Room temperature 2, sensor error
68		Room temperature 3, sensor error
70		Storage tank temperature 1 (top), sensor error
71		Storage tank temperature 2 (bottom), sensor error
72		Storage tank temperature 3 (middle), sensor error
73		Collector temperature 1, sensor error
78		Water pressure, sensor error
82		LPB address conflict
83		No BSB cable sectional/communication
84		BSB cable address conflict
85		BSB RF communication error
91		Data overwork at EEPROM
98		Additional module 1, error
99		Additional module 2, error
100		2 timer leader
102		Leader timer without redundancy
103		Communication error
105		Maintenance message
109		Boiler temperature control
110		STB (SLT) locking

Error Code	LPB Code	Error Description
111		Temperature limit safety closing
117		Water pressure is very high
118		Water pressure is very low
119		Water pressure switch disengaged
121		Heating circuit 1 flow water temperature not reached
122		Heating circuit 2 flow water temperature not reached
125		Maximum boiler temperature exceeded
126		DHW supply temperature not reached
127		DHW legionella temperature not reached
128		Flame loss in operation
129		Incorrect air supply
130		Flue gas temperature limit exceeded
132		Gas pressure switch safety shut down
133		Safety time for flame formation exceeded
146		Sensor/control element configuration error
151		LMS14... internal error
152		Parameter error
153		Device is manually locked
160		Fan speed threshold not reached
162		Air pressure switch is not closing
164		Flow/pressure switch, heating circuit error
166		Air pressure switch error, it is not opening
169		Sitherm Pro system error
170		Water pressure sensor error, primary side
171		Alarm contact 1 is active
172		Alarm contact 2 is active
173		Alarm contact 3 is active
174		Alarm contact 4 is active
176		Water pressure 2 is very high
177		Water pressure 2 is very low
178		Heating circuit 1 temperature limiter
179		Heating temperature 2 temperature limiter
183		Device is in parameter mode

Error Code	LPB Code	Error Description
195		Maximum time per charging exceeded
196		Maximum time for charging per week exceeded
209		Heating circuit error
214		Motor monitoring
215		Diverter valve fan air error
216		Boiler error
217		Sensor error
218		Pressure control
241		Flow sensor error for efficiency measurement
242		Return sensor error for efficiency measurement
243		Pool sensor error
260	217	Flow water temperature 3 <sup>rd</sup> sensor error
270	215	Heat exchanger temperature difference is too high
317	214	Mains frequency out of acceptable range
320	217	DHW supply temperature, sensor error
321	217	DHW outlet temperature, sensor error
322	218	Water pressure 3 is too high
323	218	Water pressure 3 is too low
324	146	BX inlet, same sensor
325	146	BX inlet/additional module, same sensor
326	146	BX inlet/mixture group, same sensor
327	146	Additional module, same function
328	146	Mixture group, same function
329	146	Additional module/mixture group, same function
330	146	Sensor inlet BX1 no function
331	146	Sensor inlet BX2 no function
332	146	Sensor inlet BX3 no function
333	146	Sensor inlet BX4 no function
335	146	Sensor inlet BX21 no function
336	146	Sensor inlet BX22 no function
339	146	Collector pump O5 is lost
340	146	Collector pump O16 is lost
341	146	B6 sensor is lost
342	146	Solar energy supply B31 sensor is lost
343	146	Solar energy integration is lost
344	146	Solar energy control element spare tank K8 is lost
345	146	Solar energy control element pool K18 is lost
346	146	Solid fuel boiler pump O10 is lost
347	146	Solid fuel boiler analogy sensor is lost
348	146	Solid fuel boiler address error
349	146	Accumulation tank return valve Y15 is lost

Error Code	LPB Code	Error Description
350	146	Accumulation tank address error
351	146	Main control device/system pump, address error
352	146	Unpressurized cap. address error
353	146	B10 sensor is lost
371	209	Heating circuit 3 flow water temperature
372	209	Heating circuit 3 temperature limiter
373	103	Additional module 3
374	169	Sitherm Pro calculation
375	169	BV step motor
376	169	Drift test limit value
377	169	Drift test is prevented
378	151	Internal recurrence
382	129	Recurrence speed
384	151	Auxiliary light
385	151	Mains low voltage
386	129	Fan speed tolerance
387	129	Air pressure tolerance
388	146	DHW sensor, no function
426	151	Flue gas damper feedback
427	152	Flue gas damper configuration
429	218	Dynamic water pressure is too high
430	218	Dynamic water pressure is too low
431	217	Primary heat exchanger sensor
432	151	Grounding function is not connected
433	216	Primary heat exchanger temperature is too high

## 20. SOLUTION RECOMMENDATIONS FOR SOME OF THE PROBLEMS

<b>Problem</b>	<b>Cause</b>	<b>Explanation-Recommendation</b>
Gas smell	Gas line/Gas connections	Control of leak proofing of connections is required. Be sure that measurement points are closed.
Unburned gas smell	Flue tightness	Be sure that flue connections are leak proof and measurement points are closed. Check the combustion parameters.
Incomplete combustion	Gas supply pressure	Check the gas pressure complies with stated values.
	Fan problem	Check the working of fan.
	State of premix combustion head and heat exchanger	Check the state of combustion head and heat exchanger and ensure that both are clean.
	Combustion air connection	Check that there is nothing that blocks air suction and if the impulse connection is correct.
Shaky activation of burner	Gas pressure/Combustion parameters	Check the gas pressure and combustion parameters.
No combustion after ignition	Electrode/Ionization	Check the position/state of the electrode/ionization rod.
Boiler does not work.	Electric connection	Check the fuse and electrical connections.
	Sensor connections	Ensure that connections of sensors are correct and complete.
Boiler can't reach the desired temperature.	Gas pressure	Ensure that gas pressure complies with stated values and there is constant gas flow at sufficient pressure.
	Heat exchanger	Control the state of combustion chamber.
	Boiler control	Control that boiler is at correct operation mod and temperature settings.
Safety valve activates often.	Safety valve	Ensure that safety valve settings are correct and works properly.
	Expansion tank	Check if it works properly.
Pump does not work.	Pump malfunction	Check the pump electric connections and parameters. Change the pump if there is proble in pump operation.

## 21. AFTER SALES SERVICES

Dear Customer,

We believe that providing a good service is as important as providing a good product. Therefore, we continue offering wide range of comprehensive services to our conscious customers.

Our contact details for your requests and complaints:

**Esentepe Mah.Milangaz Cad. No:75 K:3**

**Kartal Monumento Plaza**

**KARTAL/İSTANBUL/TÜRKİYE**

**Tel: +90 216 442 93 00**

**Fax: +90 216 370 45 03**

Factory Contact Details

**Türkgücü OSB**

**Bülent Ecevit Bulvarı No:11**

**ÇORLU/TEKİRDAĞ/TÜRKİYE**

**Tel: +90 282 685 44 80-81**

**Fax: +90 282 685 42 09**

You can also reach us through [www.ecodense.com](http://www.ecodense.com) website and [servis@ecodense.com](mailto:servis@ecodense.com) e-mail address.



Please observe the following recommendations.

- Use the product in accordance with the principles of this manual.
- For any service demands regarding the product, please contact our Service Center from the above-mentioned phone numbers.
- Upon your purchase, register your warranty certificate during installation.

